

Datasheet

PrismaECO-IV

Economic RGB/DVI Converter Board

Standard: Vcc = +12V; RGB & DVI: part no. PR-02-180 PrismaECO-IV-00-12RD-0L

Optional: Vcc = +24V; RGB & DVI: part no. PR-02-181 PrismaECO-IV-01-24RD-0L

Optional: Vcc = +12V; RGB only: part no. PR-02-182 PrismaECO-IV-02-12R0-0L



Version 1.21

31.05.2017

The information contained in this document has been carefully researched and is, to the best of our knowledge, accurate. However, we assume no liability for any product failures or damages, immediate or consequential, resulting from the use of the information provided herein. Our products are not intended for use in systems in which failures of product could result in personal injury. All trademarks mentioned herein are property of their respective owners. All specifications are subject to change without notice.



Table of Contents

1	Revision History	4
2	Overview	5
3	General Features	5
3.1	Software Support.....	5
4	Hardware Features.....	6
5	Input / Output Interface	7
6	OSD Menu and User Controls.....	8
6.1	4-Button OSD Keypad ZU-02-315 (IF315-00).....	8
6.2	4-Button OSD Keypad ZU-02-398 (IF398-00).....	9
7	On Screen Display Menu (OSD)	10
7.1	Image Menu.....	10
7.2	Color Sub-Menu	11
7.3	Display Menu.....	12
7.4	System Menu	13
7.5	Input Sub-Menu.....	13
7.6	OSD Settings Sub-Menu	14
7.7	Timer	14
7.8	Rotation.....	15
7.9	Position	15
7.10	Transparency	16
7.11	Keypad.....	16
7.12	Reset	17
8	Supported Input Modes	18
8.1	VGA	18
8.2	DVI – Graphics	18
8.3	DVI – Video.....	18
9	Electrical Specification	19
9.1	Absolute Maximum Ratings	19
9.2	Environmental Conditions	19
9.3	Operating Conditions.....	19



9.3.1 Maximal allowed power consumption for TFT Panels (V_{DISP})	19
9.3.2 Maximal allowed power consumption for backlight inverter (V_{BKL}).....	19
9.3.3 Maximal allowed power consumption for extended devices (V_{EXT})	20
9.3.4 Thermal Derating Characteristics	20
10 Connector Overview	21
10.1 Input Connectors	22
10.1.1 CN1: RGB Analog Input Connector	22
10.1.2 CN2: DVI Connector	22
10.1.3 CN6: Power Supply Connector	23
10.1.4 CN5: Remote Control (Debug port)	23
10.1.5 CN4: Power Supply Connector	23
10.1.6 CN13: External OSD Keypad Connector	23
10.2 Output Connector	24
10.2.1 CN10: LVDS Connector	24
10.2.2 CN20: Extra Panel Power Connector	24
10.2.3 CN27: 6 Bit TTL Signal Connector (obsolete)	25
10.2.4 CN8: TTL Signal Connector (obsolete).....	26
10.2.5 CN3: TTL Signal Connector (obsolete).....	27
10.2.6 CN11: Backlight Power Supply and Signal Connector	28
11 Supported Panels and Backlights (Inverter/Converter).....	28
12 Mechanical Specification	29
12.1 CN6: Mechanical Specification	30
12.2 CN1: Mechanical Specification	30
12.3 CN2: Mechanical Specification	31



1 Revision History

Date	Rev.No.	Description	Chapter
16.06.2015	1.0	Initial version	All
17.06.2015	1.1	CN13 Keypad optional shared signals added	10.1.6
		CN24 Light Sensor Connector added	10.2.7
22.06.2015	1.2	Maximal power consumption for 5V external devices added	9.3.2 10.1.5 10.2.6
25.06.2015	1.3	CN24 Light Sensor Connector removed	10.2.7
		CN13 Keypad optional GPIOs/I2C-Interface added	10.2.6
		Design for Test added	14
		Programming Tool specification	15
01.07.2015	1.4	Standard Keypad definition	6.1
02.07.2015	1.5	Standard Keypad definition	10.2.6
		OSD Functionality	6.
13.10.2015	1.6	Headline adjusted	9.1
09.11.2015	1.7	Thermal Derating Characteristics	9.1
13.11.2015	1.8	Extended Temperature Range -20..+80°C added	9.1
16.11.2015	1.9	Power consumption adjusted	9.3
16.11.2015	1.10	Converted Requirements to Datasheet	All
18.11.2015	1.11	TTL-Interface obsolete	All
03.12.2015	1.12	SW14 obsolete Keypad layout according to PrismaECO-III	All 6
14.01.2016	1.13	Product picture added OSD Menu and User Controls	Title page 6
09.03.2016	1.14	Product photo without TTL-Option added Product description added HDCP note added	Title page Title page 4
09.03.2016	1.15	Keypad layout and description updated	6
04.04.2016	1.16	OSD Menu screenshots updated	10-17
26.04.2016	1.17	Company logo update	All
19.07.2016	1.18	Added General Features Changing value of the width	5 29
08.11.2016	1.19	Replaces "right" key with "Select" key	7.12
13.12.2016	1.20	Changed Operating Temperature Range from -20..+80°C to -30..+80°C Added Note 10 Changed Thermal Derating Characteristics Changed Maximal allowed power (5V) and [12V] to 2A	19 20 20 19
31.05.2017	1.21	Added DDC/CI support Changed Lead-free to RoHS Changed 4-Button OSD Keypad Picture Renamed Chapter 10 to Connector Overview Changed Picture Connector Overview Moved the Connector table from Chapter 10.1 to Chapter 10 Changed Chapter 11 Supported Panels and Backlights Removed Chapter 13 News and Updates	5 5 9 21 21 22 28 32



2 Overview

The PrismaECO-IV is a graphics processing board, providing high-quality images for LCD TFT panels. This converter supports 6/8-bit LVDS panels up to WUXGA (1920 x 1200) and can be used in a variety of systems. It is developed by Distec GmbH who is able to adapt almost every TFT panel.

3 General Features

- Fully backwards compatible hardware interfaces to PrismaECO-III except TTL output
- VGA and DVI inputs
- Single/dual pixel LVDS output
- PWM (3.3V or 5V) and analog (0V – 5V) backlight intensity control
- Supports VESA DDC/CI and a subset of VESA DPMS standards
- Single board is suitable for mounting behind an LCD panel
- Four-button keypad interface and on-screen menus allow adjustments to the system
- 12V or 24V (option) main power input
- Zoom and shrink scaling
- Faroudja Real Color processing
- Analog RGB/VGA input captures 1920 x 1200 @ 60Hz
- DDC-Control on VGA and DVI ports
- Fully Customizable through the configuration software “ChandlerRover”
- RoHS
- 15.75 to 68KHz Legacy Timings
- Analog RGB Sync On Green Capable
- RS170 and RS343 Video Input Option (progressive mode only, framerate limited to panel framerate)

3.1 Software Support

- RemoteOSD protocol (will be reused from PrismaMedia-Eco)
- ChandlerRover
- ChandlerPrep



4 Hardware Features

Analog RGB Input

- Input format detection and auto-alignment
- Phase clock and image positioning
- Compatibility with all graphic cards and standard VESA modes
- Supports up to 1792x1344@60Hz or 1920x1260@60Hz or 1600x1200@75Hz standard modes
- Supports up to 1920x1440@60Hz or 2128x1200@ 60Hz with reduced blanking
- Captures up to 205MHz

Ultra-Reliable DVI Receiver

- Single Link TMDS Rx for up to 225 MHz operation
- Direct connect to all DVI compliant TMDS transmitters
- HDCP support

Intelligent Image Processing

- Programmable coefficients for user sharpness control
- Real Recovery function provides full color recovery image for refresh rates higher than those supported by the LCD panel

LVDS Output Interface

- Single/double pixel up to WUXGA (1920 x 1200 @ 60Hz) output
- Support for 8 or 6-bit panels (Enhanced dithering)
- Programmable LVDS mappings for compliance with all LVDS protocols
- Programmable channel and channel polarity swapping
- Programmable signal amplitude

On Screen Display

- Horizontal and vertical placement of OSD images
- OSD flip/rotation

Operation Modes

- Frame Sync and Free Run display synchronization modes



5 Input / Output Interface

The following drawing shows the input and output interfaces of the PrismaECO-IV. The design is implemented as a single printed circuit board.

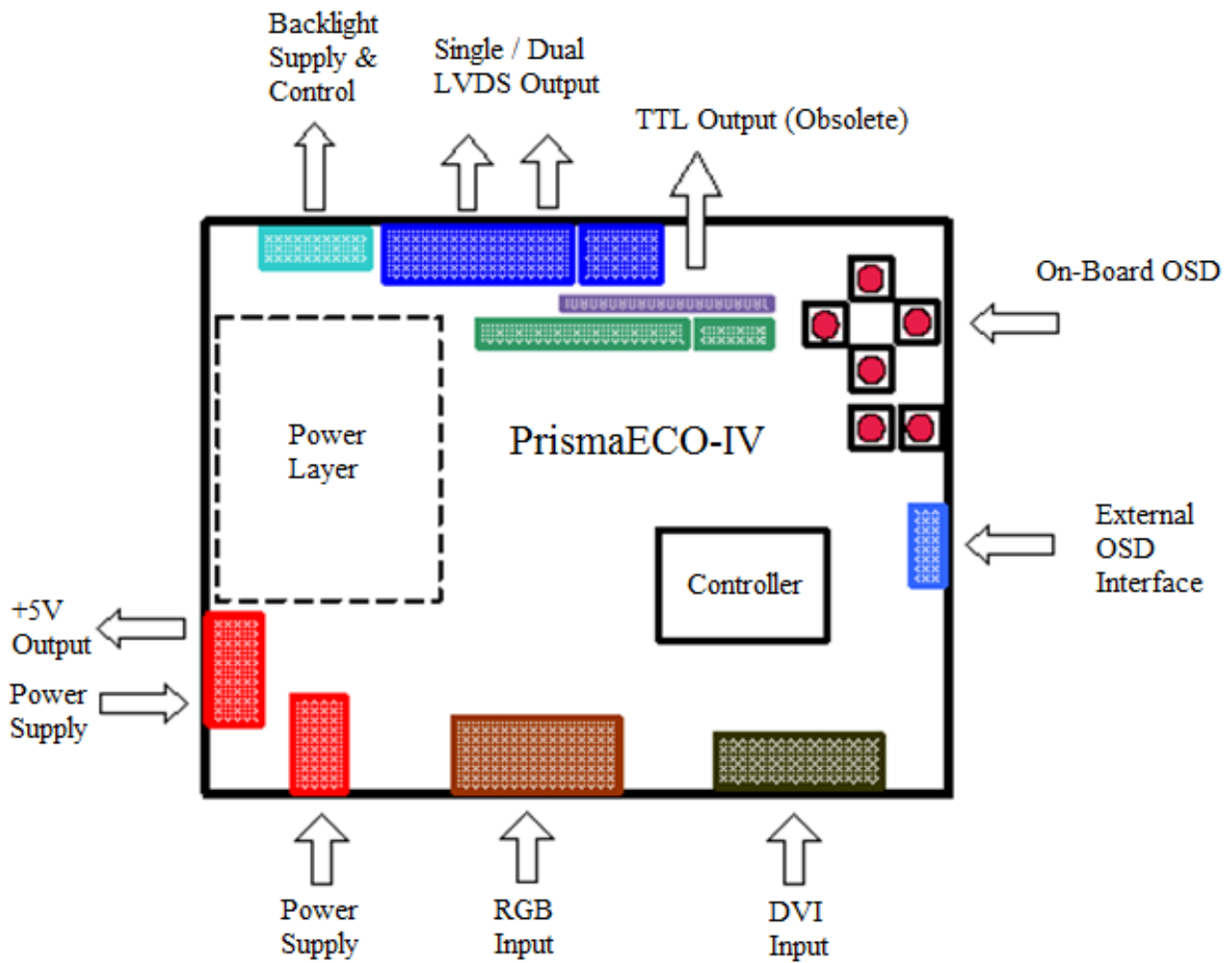

The On board OSD Keys can be populated on (standard) PCB top side or (customized) on PCB bottom side.

If the On-Board OSD-Keys are populated to the PCB bottom side and the PCB bottom side is mounted to the casing back plane then an external OSD Keypad is needless.



6 OSD Menu and User Controls

The OSD allows selection of input source and fine tuning of various functional parameters like brightness, contrast etc. These parameters can be adjusted by on board push buttons or via an external interface. Push buttons can be equipped on top or bottom side of the PrismaECO-IV. In that case no external OSD-board is necessary. Depending on the mounting of the PrismaECO-IV in the casing, the on board OSD control can simplify the construction of the casing.

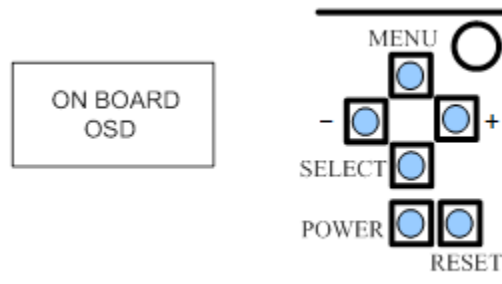

Figure 1: On Board OSD Keypad

6.1 4-Button OSD Keypad ZU-02-315 (IF315-00)

The 4-Button Keypad ZU-02-315 (IF315-00), combined with cable ZU-05-032 (Cable-FFC,14Pin,400mm,Pitch 1mm,100µm) is fully supported. The key description has to be changed to the following layout:



Figure 2: External 4 Button OSD Keypad ZU-02-315



6.2 4-Button OSD Keypad ZU-02-398 (IF398-00)

The 4-Button Keypad ZU-02-398 (IF398-00), combined with cable ZU-05-032 (Cable-FFC, 14Pin, 400mm, Pitch 1mm, 100µm) is fully supported.

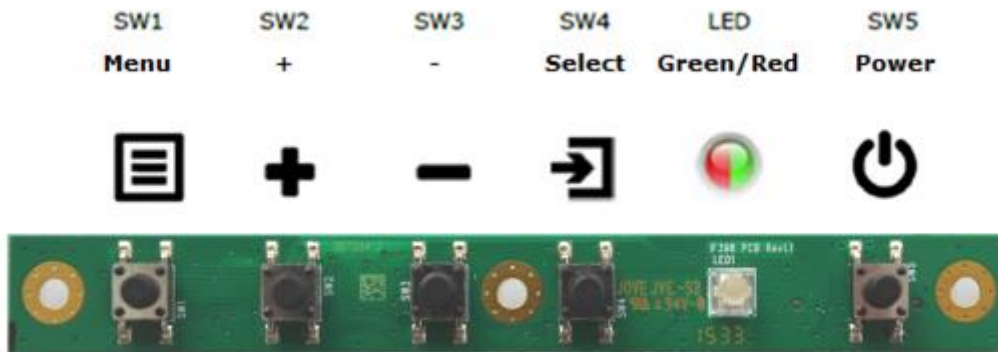

Figure 3: External 4 Button OSD Keypad ZU-02-398

The following tables give you an overview about the functionality.

	Menu	+	-	Select	LED	Power
General					See below	Power ON/OFF
OSD Closed	Open OSD	Brightness	Brightness	Input Select		
OSD Open	Exit/Back	Up/Right/+	Down/Left/-	Select		

LED Status:

- Green : Signal Found
- Green flashing : Searching Signal
- Red : Power Safe
- LED OFF : Power OFF
- Red flashing : No Panel Configuration is flashed



7 On Screen Display Menu (OSD)

7.1 Image Menu

The old style OSD of the PrismaECO-III is no longer available. It will be replaced with the new PrismaMedia-Eco-style OSD.

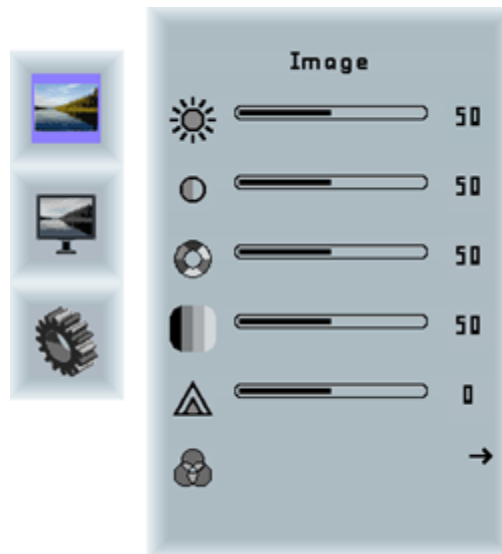

Brightness: Brightness of the image can be controlled using this function, with left and right buttons after the brightness slider is selected. This function modifies RGB data to change the brightness.

Contrast: Allows <Contrast> adjustment in the Y domain. The modification affects all color channels and all input types and is a direct multiplication of the Y data after YUV black level adjustment.

Hue: Allows <Hue> adjustment in the UV domain. The modification affects all color channels and all input types. Available if color space of input is not RGB.

Saturation: Allows <Saturation> adjustment in the UV domain. The modification affects all color channels and all input types. Available if color space of input is not RGB.

Sharpness: Allows <Sharpness> adjustment on the image.

Color: Opens the color sub-menu.



7.2 Color Sub-Menu



Auto: ADC-Calibration. It performs auto-color adjustment.

Full color: Selects full received color space.

srgb: Selects srgb color space.

xycc: Selects xycc color space.

Color Temp: Allow selection of different color temperature schemes, predefined and custom. Available if color space of input is RGB.

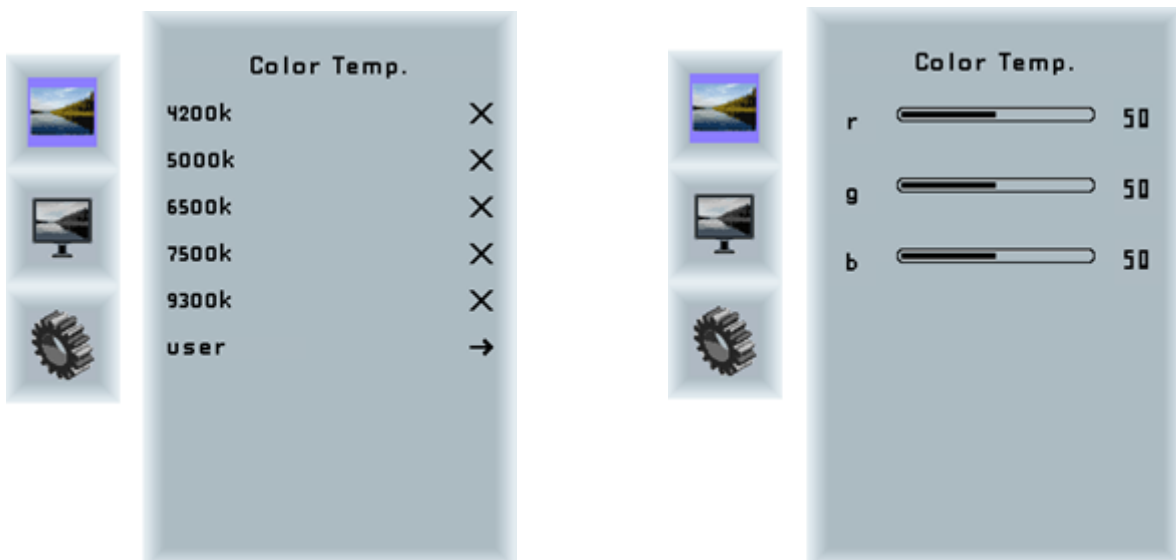



7.3 Display Menu

Available if source is VGA input.

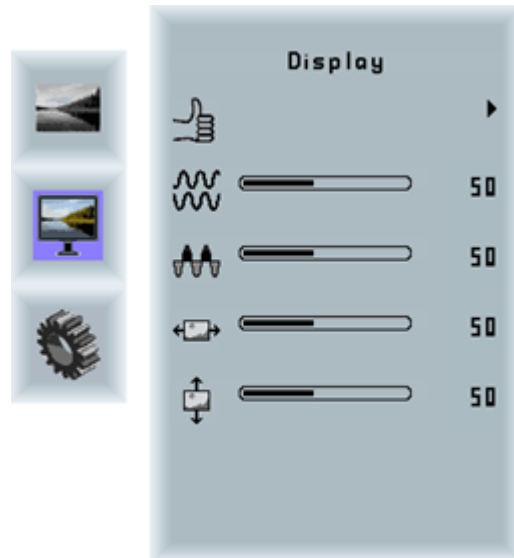

Auto-adjust: Performs auto-adjustment on the VGA input image.

Phase: This function is a slider to adjust the sampling phase of the analog interface. For optimum image quality, input pixels should be sampled at the ideal sampling points.

Clock: This function is a slider to adjust the sample clock of the analog interface. This is helpful for improving the image quality for non-standard display modes.

Display position: Used to alter placement of the image.

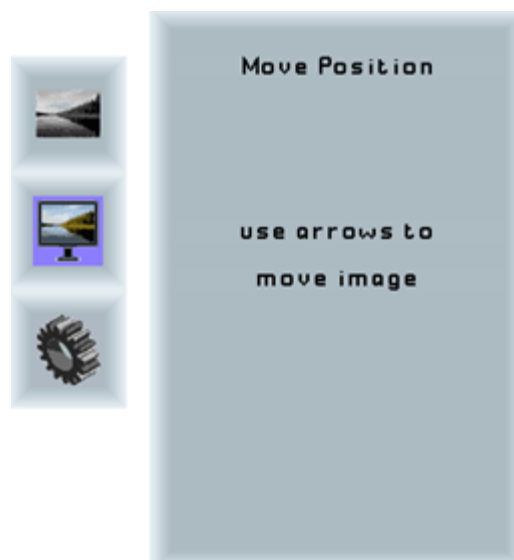



7.4 System Menu

Contains the following sub-menus:

Inputs, OSD settings, factory reset, EDID write protect, Auto Brightness and FW/OSD revision information.



There is no Auto Brightness sensor available.

7.5 Input Sub-Menu

- Manual selection of input
- Enable/disable input auto-scan

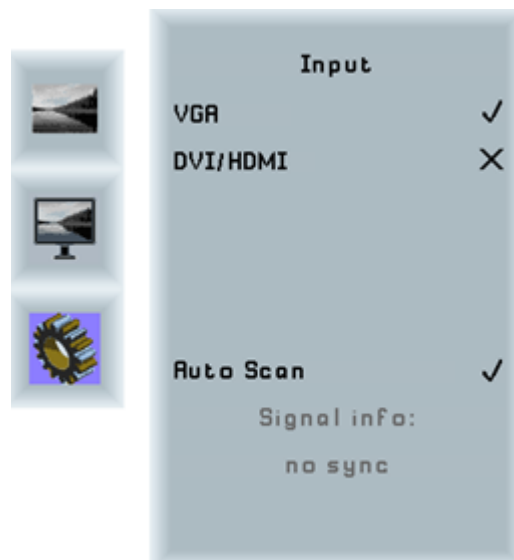



7.6 OSD Settings Sub-Menu

Contains timer, rotation, position adjustment, transparency, IR enable and Keypad switch

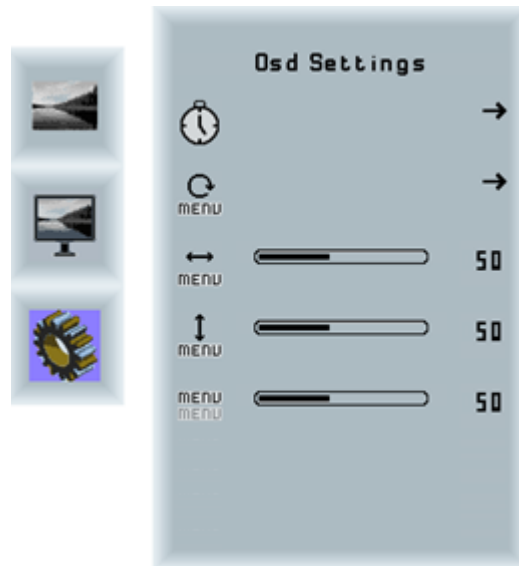

7.7 Timer

Selects how many seconds the OSD will remain active after the last use

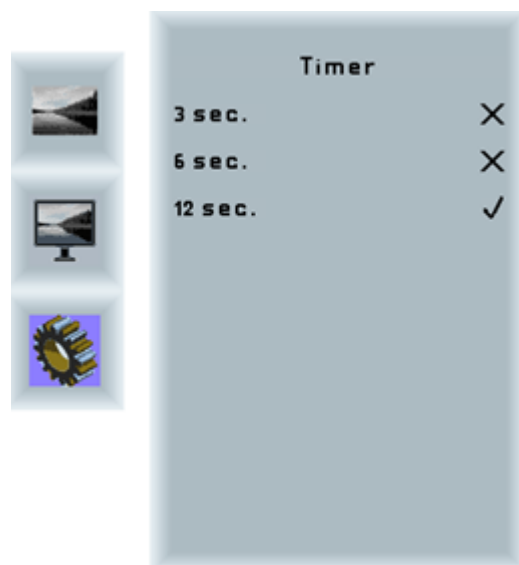



7.8 Rotation

Rotates the OSD menu

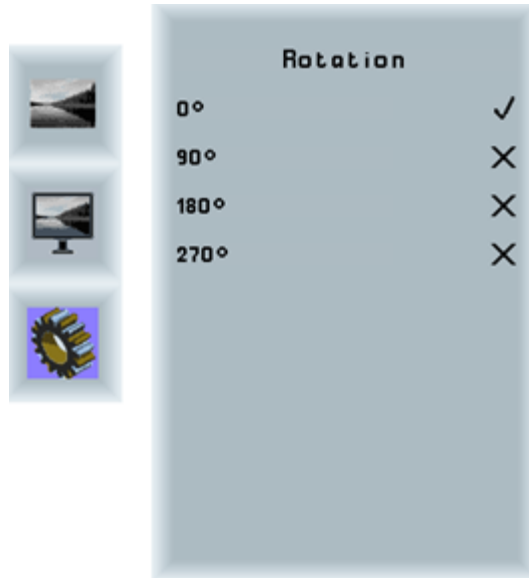

7.9 Position

Manual adjustment of OSD placement





7.10 Transparency

Selects OSD blending with background

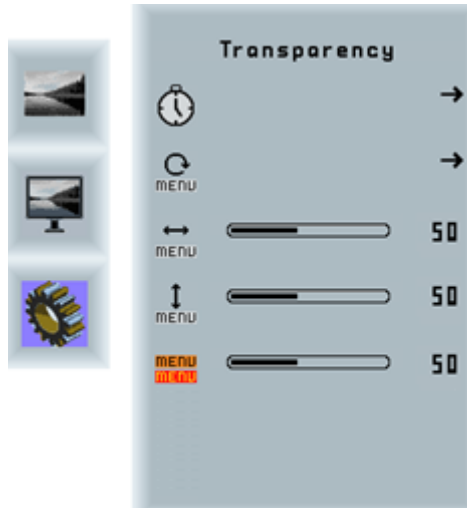

7.11 Keypad

Switch the OSD-Keypad from 6 to 4 button mode

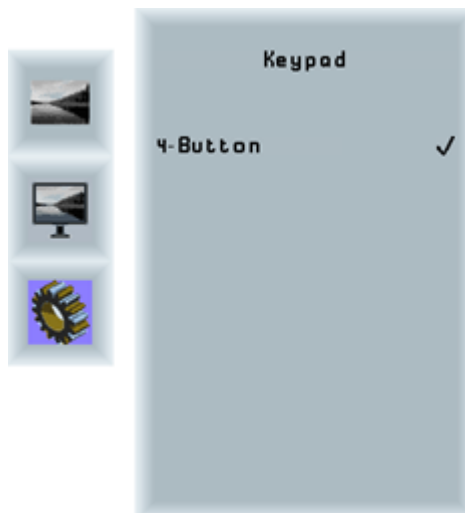



7.12 Reset

Performs a factory reset and returns all settings to default values.

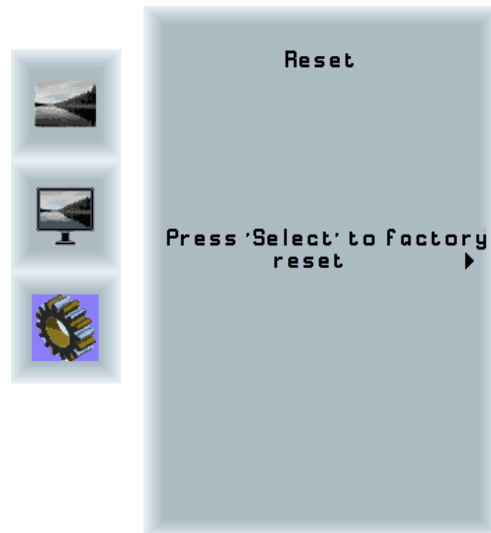



8 Supported Input Modes

The PrismaECO-IV is able to support the following input modes.

8.1 VGA

The PrismaECO-IV is equipped with one VGA connector CN1.
The factory pre-set supported input modes include:

Resolution	Resolution
640 x 480 @ 60 Hz (VESA)	1360 x 768 @ 60 Hz
800 x 600 @ 60 Hz (VESA)	1366 x 768 @ 60 Hz
1024 x 768 @ 60 Hz (VESA)	1368 x 768 @ 60 Hz
1280 x 768 @ 60 Hz	1600 x 1200 @ 60 Hz (VESA)
1280 x 800 @ 60 Hz	1920 x 1200 @ 60 Hz
1280 x 1024 @ 60 Hz (VESA)	1920 x 1080 @ 60 Hz

8.2 DVI – Graphics

The PrismaECO-IV is equipped with the DVI connector, CN2.
The factory pre-set supported input modes include:

Resolution	Resolution
640 x 480 @ 60 Hz (VESA)	1360 x 768 @ 60 Hz
800 x 600 @ 60 Hz (VESA)	1366 x 768 @ 60 Hz
1024 x 768 @ 60 Hz (VESA)	1368 x 768 @ 60 Hz
1280 x 768 @ 60 Hz	1600 x 1200 @ 60 Hz (VESA)
1280 x 800 @ 60 Hz	1920 x 1200 @ 60 Hz
1280 x 1024 @ 60 Hz (VESA)	1920 x 1080 @ 60 Hz

8.3 DVI – Video

The factory pre-set supported input modes include:

Resolution	Resolution
720 x 480 @ 60	1280 x 720 @ 60
720 x 576 @ 50	1920 x 1080 @ 50
1280 x 720 @ 50	1920 x 1080 @ 60



9 Electrical Specification

9.1 Absolute Maximum Ratings

Item	Symbol	Min.	Max.	Unit	Note
Supply Voltage	V_{IN}	-0.2	16	VDC	1), 2)
Optional Supply Voltage	V_{IN}	-0.2	30	VDC	1), 2), 4)

1), 2), 4) Please see sec. 9.3.4 "Thermal Derating Characteristics".

9.2 Environmental Conditions

Item	Symbol	Min.	Max.	Unit	Note
Operating Temperature	T_{OP}	-30	+80	°C	1)
Storage Temperature	T_{STORE}	-35	+85	°C	

1) Please see sec. 9.3.4 "Thermal Derating Characteristics".

9.3 Operating Conditions

Item	Condition	Min.	Typ.	Max.	Unit	Note
Supply Voltage		10.8	12	13.2	VDC	3)
Optional Supply Voltage		20	24	28	VDC	4)
Current Consumption	Stand-by	25	30	50	mA	5)
	Sleep mode	20	40	60	mA	5)
	Board only	110	130	170	mA	5), 6)

3), 4), 5), 6) Please see sec. 9.3.4 "Thermal Derating Characteristics". The measurements of this table are done at 25°C ambient temperature

9.3.1 Maximal allowed power consumption for TFT Panels (V_{DISP})

Item	Symbol	Max.	Unit	Note
3.3V (5V) [12V] (VDISP) Panel power	I_{DISP}	1.5 (2) [2]	A	7), 8), 9), 10)

7), 8), 9), 10) Please see sec. 9.3.4 "Thermal Derating Characteristics".

9.3.2 Maximal allowed power consumption for backlight inverter (V_{BKL})

Item	Symbol	Max.	Unit	Note
+5V Backlight power on CN11	I_{BKL}	2.0	A	8), 9), 10)
+12V Backlight power on CN11	I_{BKL}	3.0	A	9), 10)

8), 9), 10) Please see sec. 9.3.4 "Thermal Derating Characteristics".



9.3.3 Maximal allowed power consumption for extended devices (V_{EXT})

Item	Symbol	Max.	Unit	Note
+5V Extended Power Output, CN4/Pin1	I_{EXT}	2.0	A	8), 9), 10)

8), 9), 10) Please see sec. 9.3.4 "Thermal Derating Characteristics".

9.3.4 Thermal Derating Characteristics

The following graph shows the external power consumption vs. temperature characteristics of the PrismaECO-IV-01-24RD. The detailed limits for each output are described above.

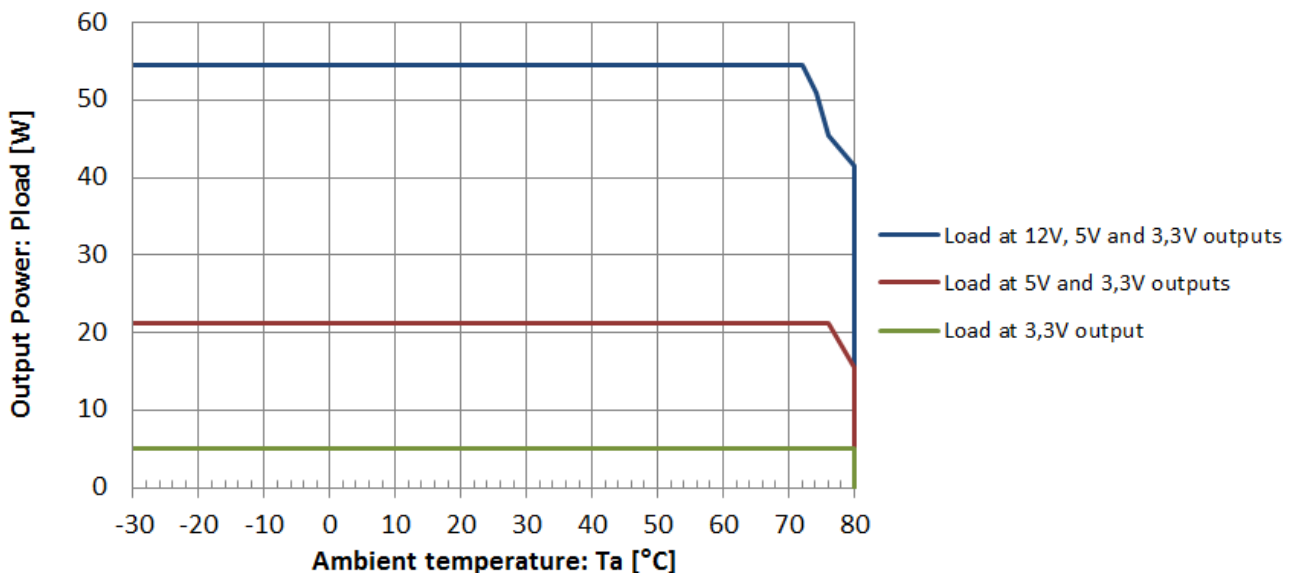

- 1) Within operating temperature range.
- 2) Permanent damage to the device may occur if maximum values are exceeded.
- 3) Limits are for PrismaECO-IV. Since the supply voltage is switched to output connectors to drive 12V panels and 12V inverter, panels and inverter supply limits must be met as well.
- 4) An optional 24V to 12V converter can be assembled on board allowing the use of 12V panels and 12V inverter together with 24V input voltage. Please ask your local sales representative for this option.
- 5) Measured at 12V input.
- 6) Please note that the current consumption of display and inverter must be added.
- 7) (V_{disp}) Panel power on CN10, CN20, CN27 and CN8. Voltage is selectable via the configuration tool
- 8) The +5V backlight power consumption is shared with the +5V External Power Supply Output on CN4/Pin1 and the +5V display power consumption.
- 9) The +3.3V power consumption is shared with the +5V and 12V power consumption, see Thermal Derating Characteristics.
- 10) Correct operation for Scaler IC STDP8028 is guaranteed from 0°C to +70°C. Specifications over the 0°C to +70°C operating temperature range are assured by design, characterization and correlation with statistical process controls.



10 Connector Overview

The following drawing shows the input and output interfaces of the PrismaECO-IV. The design is implemented as a single printed circuit board.

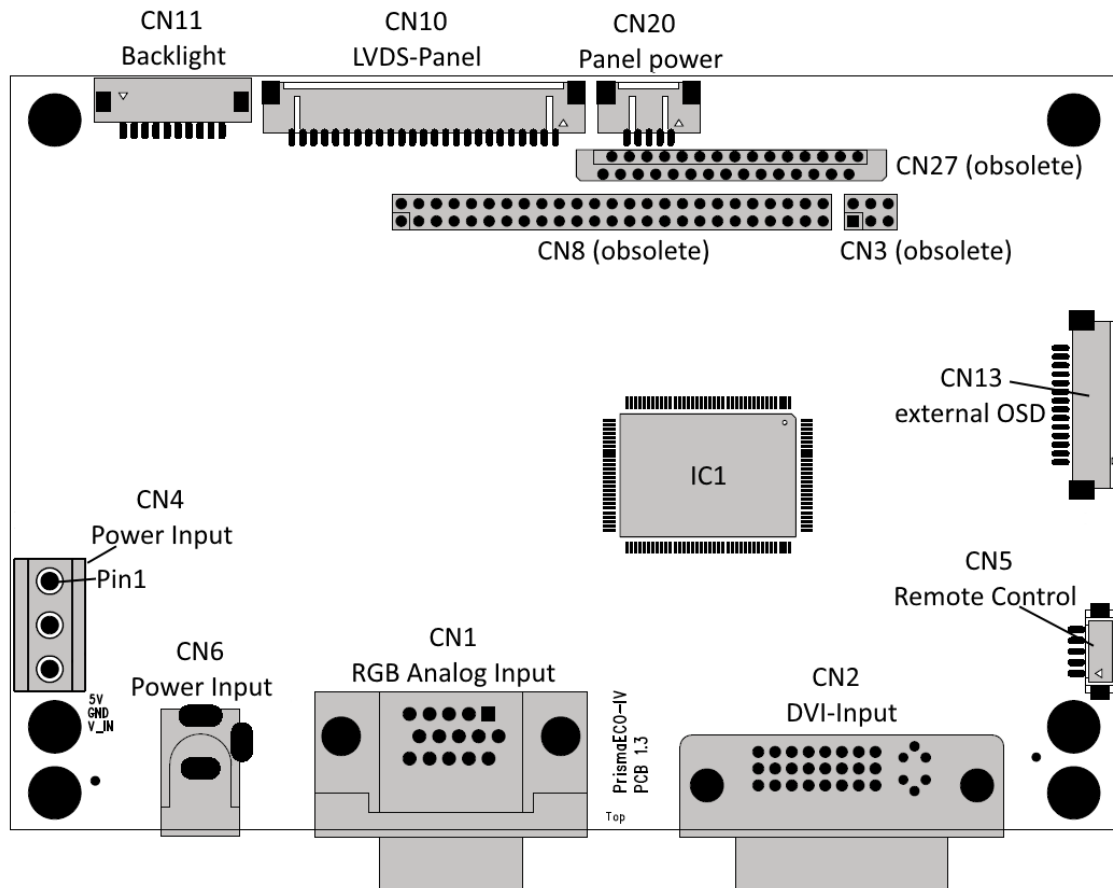

Connector	DESCRIPTION	TYPE	MANUFACTURER
CN1	RGB Analog Input	15-pin H-DSUB female	
CN2	DVI Digital Input	DVI-I female	
CN3	TTL Interface II (obsolete)	Pin header (2x3 pins, 2mm)	Nexus
CN4	Power Supply Input	Screw Terminal (5mm)	
CN5	Remote Control (Debug port (GProbe))	DF13-5P-1.25V	Hirose
CN6	Power Supply Input	Power Jack (2.0 mm pin)	
CN8	TTL Interface I (CN13)	Pin header (2x25 pins, 2mm)	Nexus
CN10	Dual LVDS	DF14-25P-1.25H	Hirose
CN11	Backlight Power Supply	DF13-10P-1.25H	Hirose
CN13	OSD Control	52271-1479	Molex
CN20	LVDS extra power	DF14-5P-1.25H	Hirose
CN27	TTL Interface (6bit) (obsolete)	52030-3029	Molex



10.1 Input Connectors

10.1.1 CN1: RGB Analog Input Connector

Pin	Signal	Description
1	RED	Analog Red
2	GREEN	Analog Green
3	BLUE	Analog Blue
4	NC	Not connected
5	VGA_CAB	Cable detection
6	GND	Ground
7	GND	Ground
8	GND	Ground

Pin	Signal	Description
9	VGA_5V	+5V DDC Supply
10	GND	Ground
11	NC	Not Connect
12	VGA_SDA	DDC Data
13	HSYNC	Horizontal Sync Input
14	VSYNC	Vertical Sync Input
15	VGA_SCL	DDC Clock

10.1.2 CN2: DVI Connector

Pin	Signal	Description
1	TMDS2-	Differential TMDS Data 2-
2	TMDS2+	Differential TMDS Data 2+
3	GND	TMDS Shield
4	NC	Not connected
5	NC	Not connected
6	DVI_SCL	DDC data clock
7	DVI_SDA	DDC data
8	NC	Not connected
9	TMDS1-	Differential TMDS Data 1-
10	TMDS1+	Differential TMDS Data 1+
11	GND	TMDS Shield
12	NC	Not connected
13	NC	Not connected
14	DVI_5V	+5V DDC Supply
15	GND	Ground

Pin	Signal	Description
16	DISPDET	Hot Plug Detection
17	TMDS0-	Differential TMDS Data 0-
18	TMDS0+	Differential TMDS Data 0+
19	GND	TMDS Shield
20	NC	Not connected
21	NC	Not connected
22	GND	TMDS Clock Shield
23	TMDSCL+	Differential TMDS Clock +
24	TMDSCL-	Differential TMDS Clock -
C1	NC	Not connected
C2	NC	Not connected
C3	NC	Not connected
C4	NC	Not connected
C5	NC	Not connected



10.1.3 CN6: Power Supply Connector

Pin	Signal	Description
Center	V _{IN}	12V/(24V optional) Power supply (up to 5A)
Bottom	GND	Ground

10.1.4 CN5: Remote Control (Debug port)

Pin	Signal	Description
1	UART_DO	TxD for FW Programming
2	UART_DI	RxD for FW Programming
3	+3.3V	+3.3V Power
4	+5V	+5V Power
5	GND	Ground

10.1.5 CN4: Power Supply Connector

Pin	Signal	Description
1	+5V	5V output (up to 2A, shared with Backlight power on CN11)
2	GND	Ground
3	V _{IN}	12V/(24V optional) Power supply input (up to 5A)

10.1.6 CN13: External OSD Keypad Connector

Pin	Signal	Description
1	GND	GND
2	+5V	+5V supply
3	+3.3V	+3.3V supply
4	POWER_ON/OFF	System power on/off
5	LED_GREEN	Status LED green (signal good)
6	LED_RED	Status LED red (no signal)
7	LBADC_IN1	For use with voltage controlled keypad
8	KEY_OPT1	GPIO43
9	KEY_OPT2	GPIO17 / I2C_MSTR_SDA
10	KEY_OPT3	GPIO18 / I2C_MSTR_SCL
11	KEY_DOWN	OSD - Key DOWN (-)
12	KEY_UP	OSD - Key UP (+)
13	KEY_EXIT	OSD - Key EXIT
14	KEY_MENU	OSD - Key MENU



10.2 Output Connector

10.2.1 CN10: LVDS Connector

Pin	Signal	Description
1	V _{DISP}	Panel power supply selectable +3.3V (+5V) [+12V]
2	V _{DISP}	Panel power supply selectable +3.3V (+5V) [+12V]
3	GND	Ground
4	GND	Ground
5	TXA3+	LVDS data 1st pixel
6	TXA3-	LVDS data 1st pixel
7	TXACLK+	LVDS clock 1st pixel clock
8	TXACLK-	LVDS clock 1st pixel clock
9	TXA2+	LVDS data 1st pixel
10	TXA2-	LVDS data 1st pixel
11	TXA1+	LVDS data 1st pixel
12	TXA1-	LVDS data 1st pixel
13	TXA0+	LVDS data 1st pixel
14	TXA0-	LVDS data 1st pixel
15	TXB3+	LVDS data 2nd pixel
16	TXB3-	LVDS data 2nd pixel
17	TXBCLK+	LVDS data 2nd pixel clock
18	TXBCLK-	LVDS data 2nd pixel clock
19	TXB2+	LVDS data 2nd pixel
20	TXB2-	LVDS data 2nd pixel
21	TXB1+	LVDS data 2nd pixel
22	TXB1-	LVDS data 2nd pixel
23	TXB0+	LVDS data 2nd pixel
24	TXB0-	LVDS data 2nd pixel
25	BKLT_EN	Backlight Enable Signal (Voltage Level selectable +3.3V or 5V)

10.2.2 CN20: Extra Panel Power Connector

Pin	Signal	Description
1	LVDS_OPT	LVDS option pin selectable +3.3V H/L / +5V H/L
2	V _{DISP}	Panel power supply selectable +3.3V (+5V) [+12V]
3	V _{DISP}	Panel power supply selectable +3.3V (+5V) [+12V]
4	GND	Ground
5	GND	Ground



10.2.3 CN27: 6 Bit TTL Signal Connector (obsolete)

Pin	Signal	Description (*)
1	GND	Ground
2	CLK	Pixelclock
3	GND	Ground
4	HSYNC	Horizontal sync
5	VSYNC	Vertical sync
6	GND	Ground
7	ARED2	Red 2
8	ARED3	Red 3
9	ARED4	Red 4
10	ARED5	Red 5
11	ARED6	Red 6
12	ARED7	Red 7
13	GND	Ground
14	AGREEN2	Green 2
15	AGREEN3	Green 3
16	AGREEN4	Green 4
17	AGREEN5	Green 5
18	AGREEN6	Green 6
19	AGREEN7	Green 7
20	GND	Ground
21	ABLUE2	Blue 2
22	ABLUE3	Blue 3
23	ABLUE4	Blue 4
24	ABLUE5	Blue 5
25	ABLUE6	Blue 6
26	ABLUE7	Blue 7
27	GND	Ground
28	DE	Display enable signal
29	VDISP	Panel power supply selectable +3.3V (+5V) [+12V]
30	VDISP	Panel power supply selectable +3.3V (+5V) [+12V]

(*) see note on page 27



10.2.4 CN8: TTL Signal Connector (obsolete)

Pin	Signal	Description (*)
1	+12V	Optional +12V Power supply
2	+12V	
3	GND	Ground
4	GND	
5	VDISP	Panel power supply selectable +3.3V (+5V) [+12V]
6	VDISP	Panel power supply selectable +3.3V (+5V) [+12V]
7	NC	Not connected
8	GND	Ground
9	ABLUE2	Blue data 2
10	ABLUE3	Blue data 3
11	ABLUE4	Blue data 4
12	ABLUE5	Blue data 5
13	ABLUE6	Blue data 6
14	ABLUE7	Blue data 7
15	NC	Not connected
16	NC	Not connected
17	NC	Not connected
18	NC	Not connected
19	NC	Not connected
20	NC	Not connected
21	AGREEN2	Green data 2
22	AGREEN3	Green data 3
23	AGREEN4	Green data 4
24	AGREEN5	Green data 5
25	AGREEN6	Green data 6
26	AGREEN7	Green data 7
27	NC	Not connected
28	NC	Not connected
29	NC	Not connected
30	NC	Not connected
31	NC	Not connected
32	NC	Not connected
33	ARED2	Red data 2
34	ARED3	Red data 3
35	SCLK	Pixel clock
36	VS	Vertical Sync



Pin	Signal	Description (*)
37	DE	Display Enable
38	HS	Horizontal Sync
39	GND	Ground
40	BKLT_EN	Backlight Enable Signal (Voltage Level selectable +3.3V or 5V)
41	ARED4	Red data 4
42	ARED5	Red data 5
43	ARED6	Red data 6
44	ARED7	Red data 7
45	ABLUE0	Blue data 0
46	ABLUE1	Blue data 1
47	AGREEN0	Green data 0
48	AGREEN1	Green data 1
49	ARED0	Red data 0
50	ARED1	Red data 1

10.2.5 CN3: TTL Signal Connector (obsolete)

Pin	Signal	Description (*)
1	ABLUE0	Blue data 0
2	ABLUE1	Blue data 1
3	AGREEN0	Green data 0
4	AGREEN1	Green data 1
5	ARED0	Red data 0
6	ARED1	Red data 1

(*) Note to all TTL connectors:

For an arrangement of the color bits as listed in these tables the mapping in FW must be set to VESA/non-conventional.



10.2.6 CN11: Backlight Power Supply and Signal Connector

Pin	Signal	Description
1	V _{BKL}	+12V Backlight power supply
2	GND	Ground
3	BKLT_EN	Backlight Enable Signal
4	BRT_ADJ	Brightness Control Signal
5	+5V	Backlight power supply (Shared with +5V Power Supply output on CN4)
6	+5V	Backlight power supply (Shared with +5V Power Supply output on CN4)
7	V _{BKL}	+12V Backlight power supply
8	V _{BKL}	+12V Backlight power supply
9	GND	Ground
10	GND	Ground

11 Supported Panels and Backlights (Inverter/Converter)

Panels and Backlights Options (*)	Hardware Options
Panel Voltage (V _{DISP})	3.3V
	5V
	12V
Pixel Per Clock	1
	2
Option Pin 0 Voltage Level (CN20, LVDS_OPT)	0V
	3.3V
	5V
Backlight Voltage (CN11, V _{BKL})	12V
Backlight Control Type	PWM
	Analog
Voltage Level of PWM Signal (BRT_ADJ)	3.3V or 5V
Voltage Level (Analog) (BRT_ADJ)	0V – 5V
Voltage Level of Backlight Enable Signal (BKLT_EN)	3.3V or 5V

(*) PrismaECO-IV supports Panels with a:

- Resolution up to WUXGA (1920 x 1200) @ 60 Hz.
- LVDS input signal for single/dual pixel and Bit Depth of 6/8 bit.
- TTL input signal for single pixel 6/8-bit (obsolete).

With the (LVDS_OPT) LVDS Option Pin panel side selectable things (maybe swap display or switch LVDS data mapping etc.)



12 Mechanical Specification

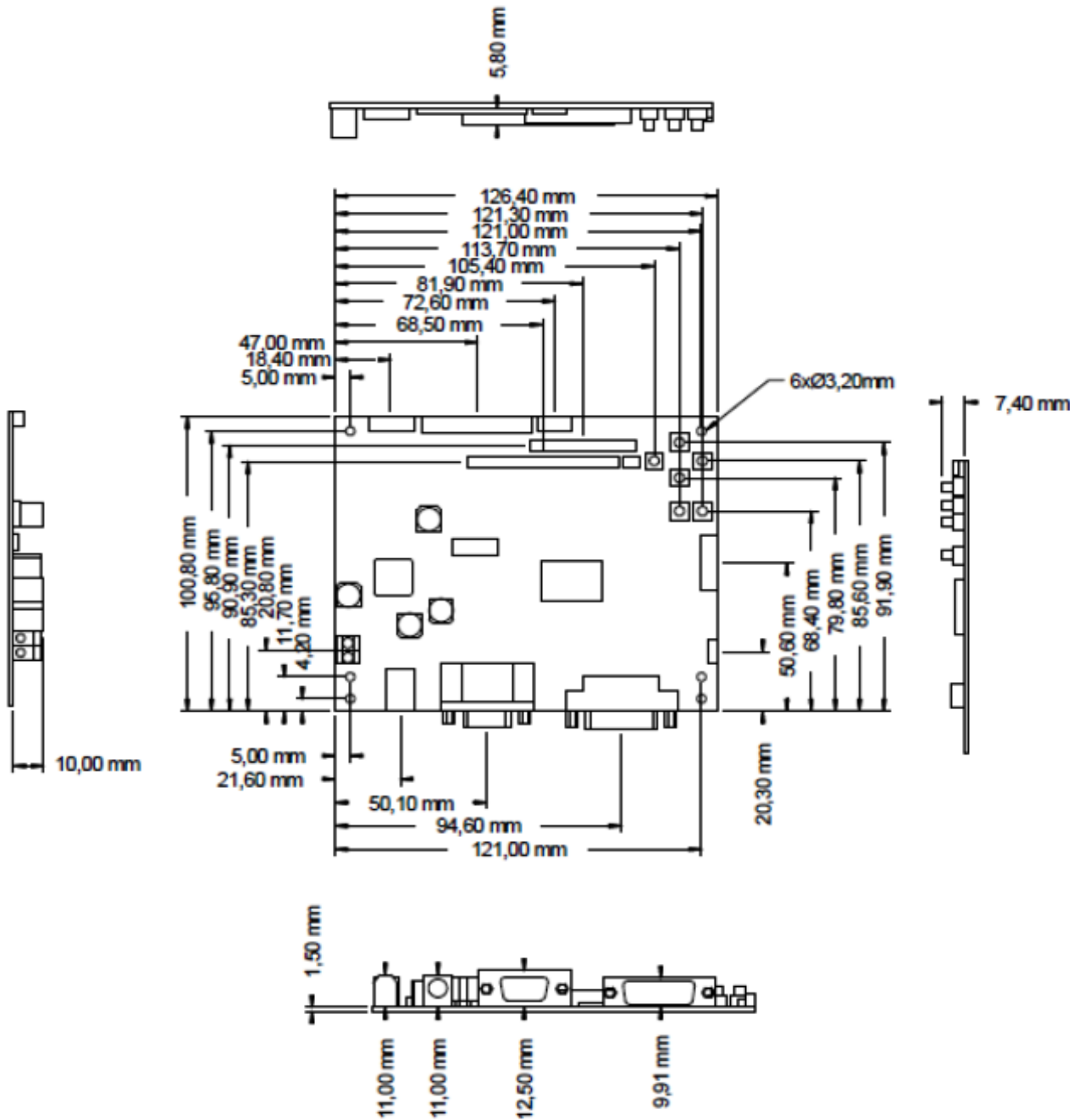

ITEM	DESCRIPTION	REMARKS
Length	126.4mm	± 0.2mm
Width	100.8mm	± 0.5mm
Height	16.3mm	± 0.2mm
Weight (PR-02-180)	86g	
Weight (PR-02-181)	94g	
Weight (PR-02-182)	TBD	



12.1 CN6: Mechanical Specification

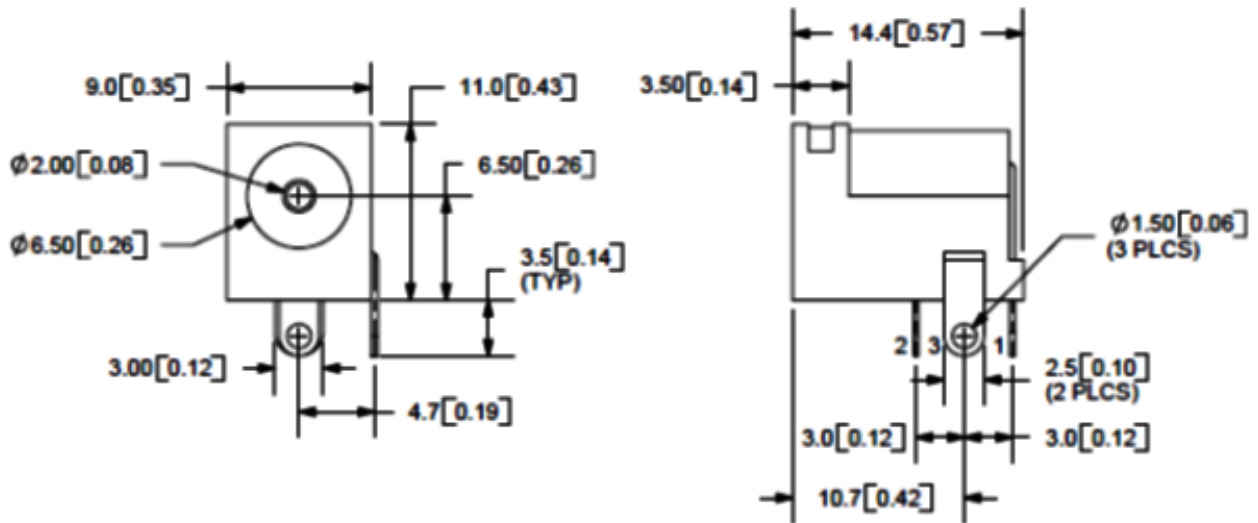

Figure 4: CN6 Power Connector: Units: mm [inches]

12.2 CN1: Mechanical Specification

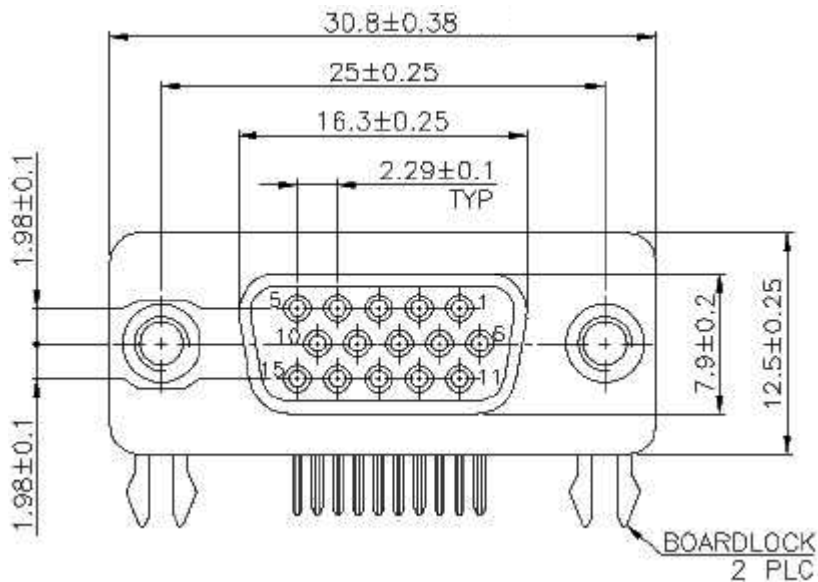

Figure 5: CN1 RGB Connector: Units: mm



12.3 CN2: Mechanical Specification

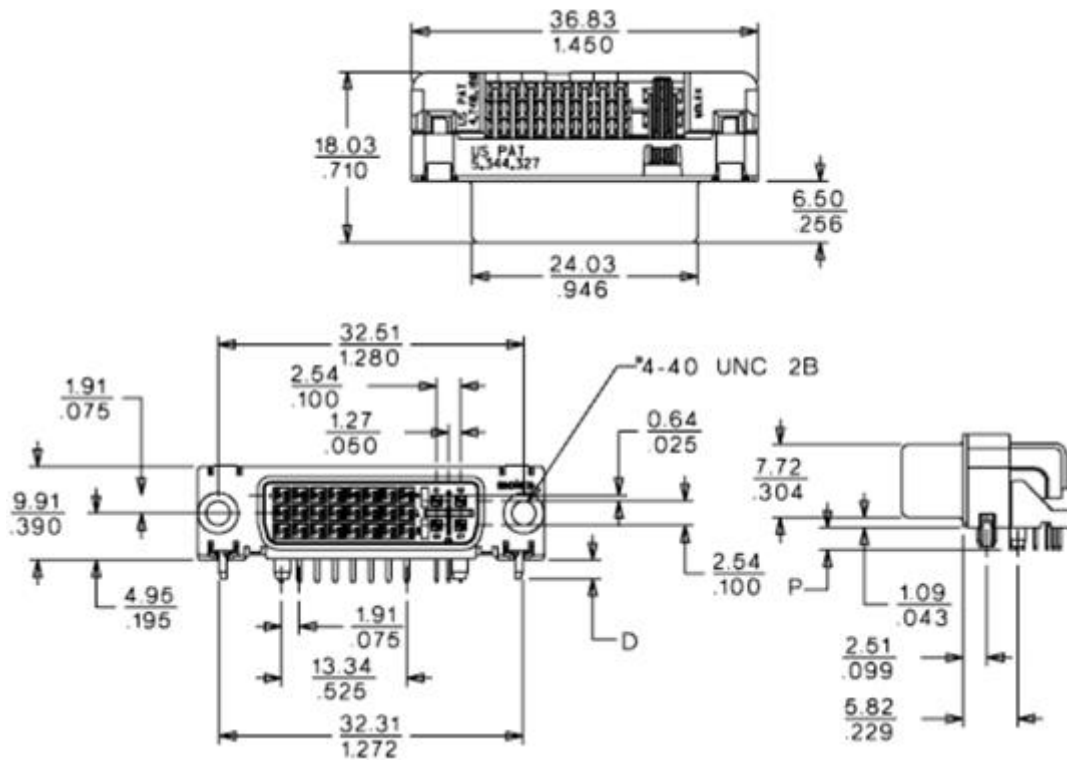

Figure 6: CN2 DVI Connector: Units: mm/inches

Our company network supports you worldwide with offices in Germany, Great Britain, Turkey and the USA.
For more information please contact:



DATA DISPLAY GROUP

A **FORTEC** GROUP MEMBER

Distec GmbH

Augsburger Str. 2b
82110 Germering
Germany

Phone: +49 (0)89 / 89 43 63-0
Fax: +49 (0)89 / 89 43 63-131
E-Mail: info@datadisplay-group.de
Internet: www.datadisplay-group.de

FORTEC Elektronik AG

Lechwiesenstr. 9
86899 Landsberg am Lech
Germany

Phone: +49 (0)8191 / 911 72-0
Fax: +49 (0)8191 / 217 70
E-Mail: sales@fortecag.de
Internet: www.fortecag.de

Display Technology Ltd.

5 The Oaks Business Village
Revenge Road, Lordswood
Chatham, Kent, ME5 8LF
United Kingdom

Phone: +44 (0)1634 / 67 27 55
Fax: +44 (0)1634 / 67 27 54
E-Mail: info@displaytechnology.co.uk
Internet: www.datadisplay-group.com

Apollo Display Technologies, Corp.

87 Raynor Avenue,
Unit 1 Ronkonkoma,
NY 11779

United States of America
Phone: +1 631 / 580-43 60
Fax: +1 631 / 580-43 70
E-Mail: info@apolloDisplays.com
Internet: www.apolloDisplays.com

Sales Partner:

DATA DISPLAY BİLİŞİM TEKNOLOJİLERİ

İÇ VE DIŞ TİCARET LİMİTED ŞİRKETİ

Barbaros Mh. Ak Zambak Sk. A Blok D:143

34376 Ataşehir / İstanbul

Turkey

Phone: +90 (0)216 / 688 04 68

Fax: +90 (0)216 / 688 04 69

E-Mail: info@data-display.com.tr

Internet: www.data-display.com.tr