

OUR GLOBAL
COMPETENCE
CENTRES

Preliminary

 APOLLO DISPLAY
TECHNOLOGIES



 DISTEC



 DISPLAY
TECHNOLOGY



Datasheet

Distec

PrismaECOeDP-II

LCD-panel controller with eDP-output

PR-02-195 (12V Version)

PR-02-196 (24V Version)

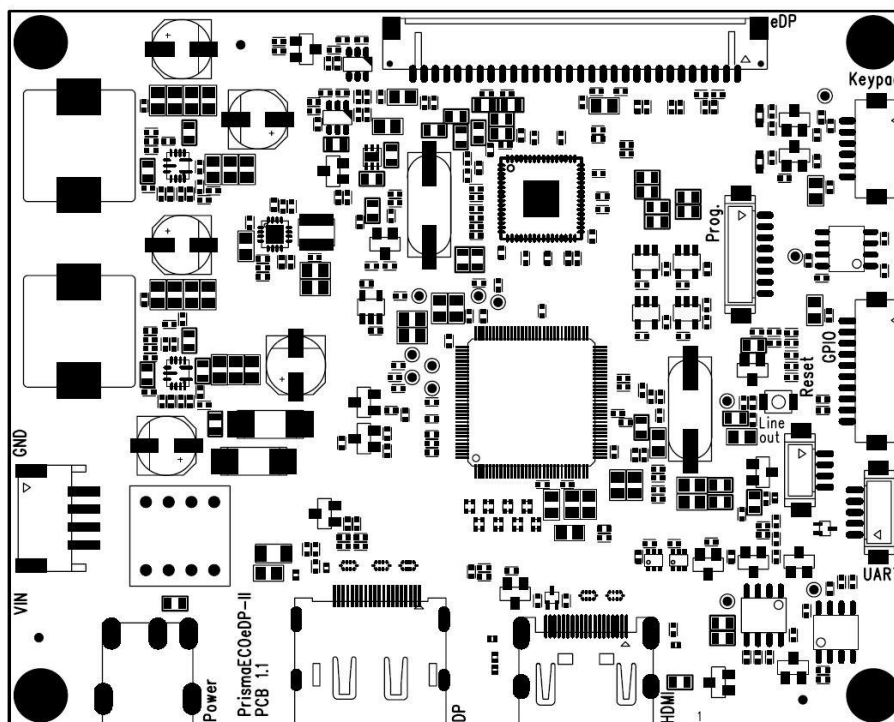

Version 1.0

06.02.2023

The information contained in this document has been carefully researched and is, to the best of our knowledge, accurate. However, we assume no liability for any product failures or damages, immediate or consequential, resulting from the use of the information provided herein. Our products are not intended for use in systems in which failures of product could result in personal injury. All trademarks mentioned herein are property of their respective owners. All specifications are subject to change without notice.

Table of Contents

1	Revision History	5
2	Overview	6
3	Warnings	6
4	Features	6
5	Hardware Features	7
6	OSD Menu and User Controls	8
6.1	OSD Control through External Keypad	8
6.2	OSD control through Remote OSD (ROSD)	9
7	On-Screen-Menu	10
7.1	Brightness/Contrast Tab	10
7.2	Color Settings Tab	10
7.3	Input Source Tab	11
7.4	Display Settings Tab	11
7.5	Other Settings Tab	12
7.6	Information Tab	12
7.7	External Devices Tab	13
7.7.1	Submenu "Ambient Light Sensor":	13
7.7.2	Submenu "Temperature Sensor":	14
7.7.3	Submenu "Controllers":	14
7.8	Input Source Window	15
7.9	Volume Control	15
7.10	Brightness Control	15
8	Supported Input Modes	16
8.1	HDMI – Graphics	16
8.2	HDMI – Video	16
8.3	DisplayPort	17
9	Absolute Maximum Ratings	18
10	Electrical Characteristics	18
11	Mechanical Dimensions	19
12	Connector Overview	20

13 Input Connectors	21
14 Output Connectors	23
15 I/O Connector	25
16 Supported Panels and Backlight Converter	26
17 Hardware Information	26
18 Accessories	27
18.1 Light Sensor ZU-02-412	27
18.2 Temperature Sensor ZU-02-389	27
18.3 Frozen Screen Detector ZU-02-512	27
19 Programming, configuration and ROSD via serial port	28
19.1 HW requirements	28

Preliminary

1 Revision History

Date	Rev.No.	Description	Page
06.02.2023	1.0	Initial version (preliminary)	All

Preliminary

2 Overview

PrismaECOeDP-II is a graphics processing board, providing high quality images for TFT-LCD panels with eDP interface. The board supports TFT panels up to WUXGA (1920 x 1200) resolution and can be used in a variety of systems.

3 Warnings

Although the PrismaECOeDP-II is using protection circuits for most of its interfaces, it is strongly recommended to prevent the attached devices from drawing too much current from the PrismaECOeDP-II.

4 Features

- 12V or 24V main power input (depending on Hardware-Version)
- DP1.2a, HDMI 1.3 (compatible with HDMI 1.4) and DVI 1.0 compliant receiver
- eDP Output - 2 lanes for panels with up to 1920x1200@60Hz resolution
- Supports 18 and 24-bit color depths.
- Support OSD Rotation 0, 90, 180, 270 degrees
- 3.3 V panel supply
- 12V backlight supply
- Audio Line Out
- PWM controlled backlight dimming.
- Supports VESA DDC/CI on HDMI and Display Port
- Controls / OSD
 - Four-button external OSD - keypad interface
 - External RS-232 (debugging and RemoteOSD)
- Additional features
 - GPIO and I2C connector
- Auto Brightness regulation in combination with an ambient light sensor (optional accessory available)
- Supports temperature sensor (optional accessory available)
- Supports "Frozen-Screen Detection System" (optional accessory available)
- Software Support
 - RemoteOSD protocol
 - Fully Customizable through the configuration software MStarRover

5 Hardware Features

Ultra-Reliable HDMI 1.3 Receiver

- Single Link TMDS Rx for up to 12-bit 1080p
- Captures up to 225MHz.
- Direct connect to all HDMI compliant TMDS transmitters
- No HDCP support

DisplayPort 1.1a Receiver

- 10.8Gbps total bandwidth over 4 lanes
- No HDCP support

Embedded DisplayPort Output

- eDP output compliant with DisplayPort 1.1a
- Supports two lanes with HBR (2.7Gbps) and RBR (1.62Gbps)
- Output resolution up to 1920x1200@60Hz

Audio Output

- Line audio output for HDMI/DP embedded audio

On Screen Display

- Supports OSD rotation degree 0°, 90°, 180°, 270°
- Support 2/4/8/16 multi-color font

Preliminary

6 OSD Menu and User Controls

The OSD allows selection of input source and fine tuning of various functional parameters like brightness, contrast etc. These parameters can be adjusted via an external interface.

6.1 OSD Control through External Keypad

The 4-button OSD-Keypad **ZU-02-398** can be used to control the OSD:

Cable to be used with Keypads: **KA-30-613** (connect to CON5)

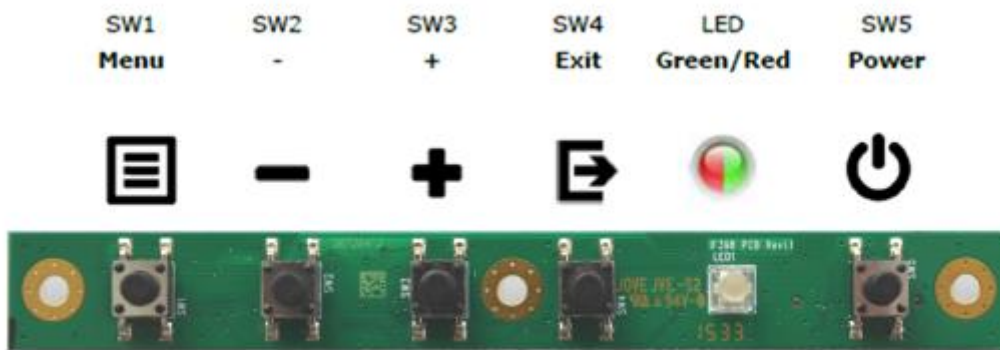

The following table gives you an overview about the functionality:

	Menu	-	+	Exit	LED	Power
General					See below	Power ON/OFF
OSD closed	Open OSD	Volume	Brightness	Input Select		
OSD open	Select	Down/Left/-	Up/Right/+	Exit/Back		

LED Status:

- Green: Signal Found
- Green flashing: Searching Signal
- Red: Power Safe
- Red flashing: Blank or corrupted panel config data. Please contact Data Display support.
- LED OFF: Power OFF

6.2 OSD control through Remote OSD (ROSD)

The PrismaECOeDP-II can be controlled with the ROSD Protocol (Remote OSD) via the COM/USB port of your PC. The ROSD Protocol is a proprietary Distec protocol.

You may need an interface board IF430 (ZU-02-430) to convert the RS232 voltage levels of the COM port to the 3.3V UART levels of PrismaECOeDP-II (CON8).

Details can be found in "MStar-ROSD.pdf" or contact Distec customer service.

Preliminary

7 On-Screen-Menu

Please note: For technical reasons OSD menu is only available when horizontal output resolution(active) exceeds 696 pixels.

7.1 Brightness/Contrast Tab



Brightness: Brightness of the image can be controlled using this function, with left and right buttons after the brightness slider is selected. This function modifies RGB data or Backlight brightness (depending on configuration) to change the brightness.

Contrast: Allows <Contrast> adjustment in the Y domain. The modification affects all color channels and all input types and is a direct multiplication of the Y data after YUV black level adjustment.

7.2 Color Settings Tab

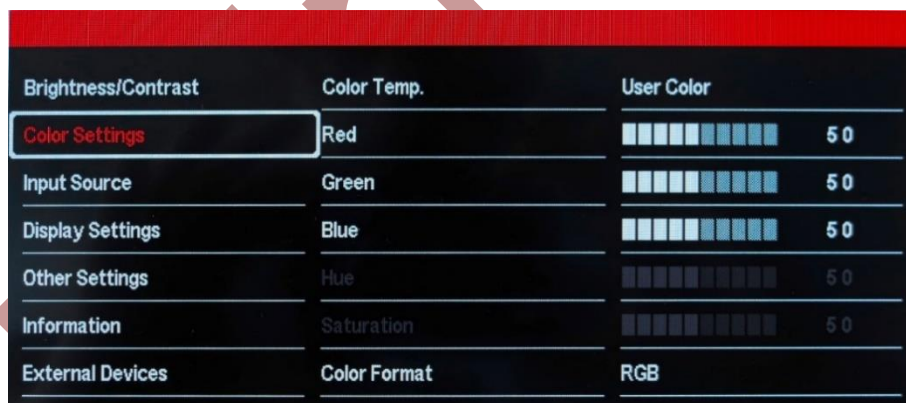

Color Temp: Allows selection of different color temperature schemes, predefined and custom. Available if the color space of the input is RGB.

Red, Green, Blue: Control the amount of the corresponding color components in the displayed image.

Hue: Allows <Hue> adjustment in the UV domain. The modification affects all color channels and all input types. Available if the color space of an input is not RGB.

Saturation: Allows <Saturation> adjustment in the UV domain. The modification affects all color channels and all input types. Available if the color space of an input is not RGB.

Color Format: Switches between RGB and YUV color spaces.

7.3 Input Source Tab

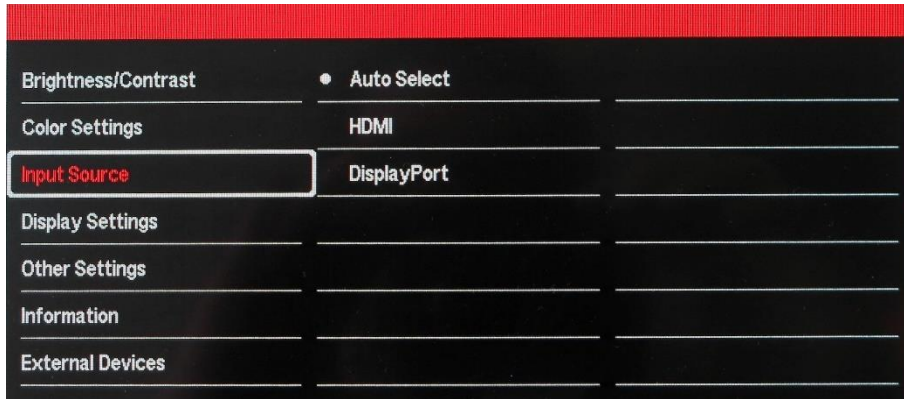

Enables the manual selection of the input source, **Auto Select** enables / disables input auto-detection.

7.4 Display Settings Tab

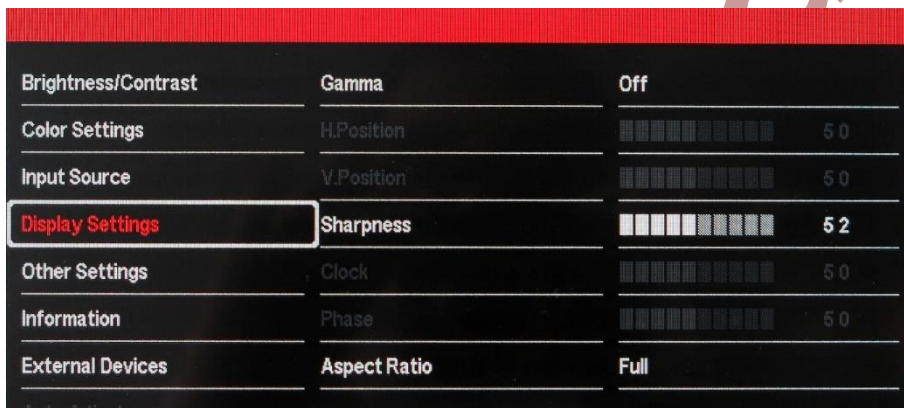

Gamma: Enables or disables the gamma correction.

Sharpness: Allows <Sharpness> adjustment of the image.

Aspect Ratio: Allows adjustment of the display's width to height proportions.

7.5 Other Settings Tab

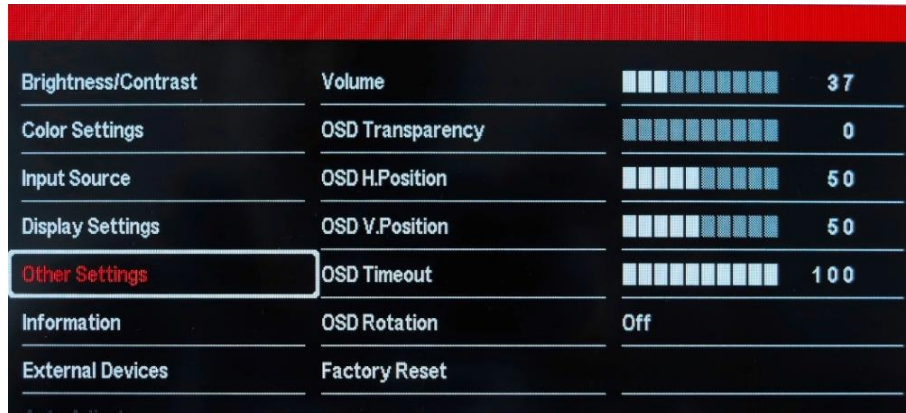

Volume: Sets the volume of the sound

OSD Transparency: Sets the transparency level of the OSD Menu on the 0 to 5 scale (0 – not transparent, 5 – barely visible)

OSD H.Position: Sets the horizontal OSD Menu position on the screen (in percent of the horizontal screen resolution)

OSD V.Position: Sets the vertical OSD Menu position on the screen (in percent of the vertical screen resolution)

OSD Timeout: Selects how many seconds the OSD will remain active after the last action has been performed.

OSD Rotation: Rotates the OSD Menu by 90, 180 or 270 degrees.

Factory Reset: Resets the display settings to the default ones.

7.6 Information Tab

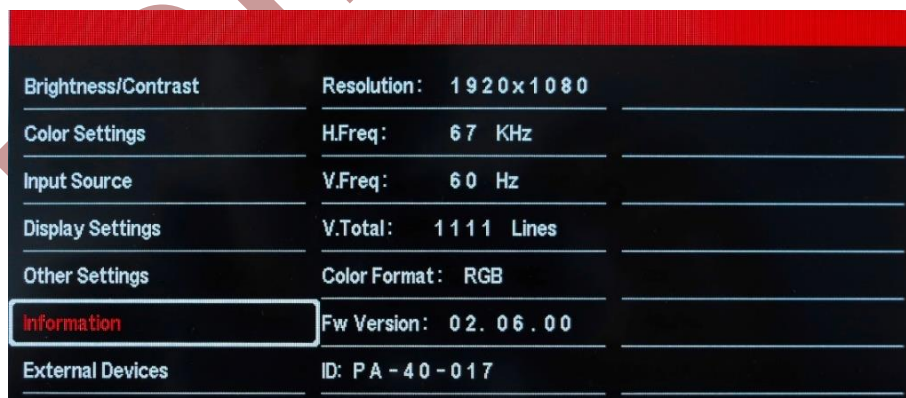

Shows Input Resolution and FW revision and ID information.

7.7 External Devices Tab

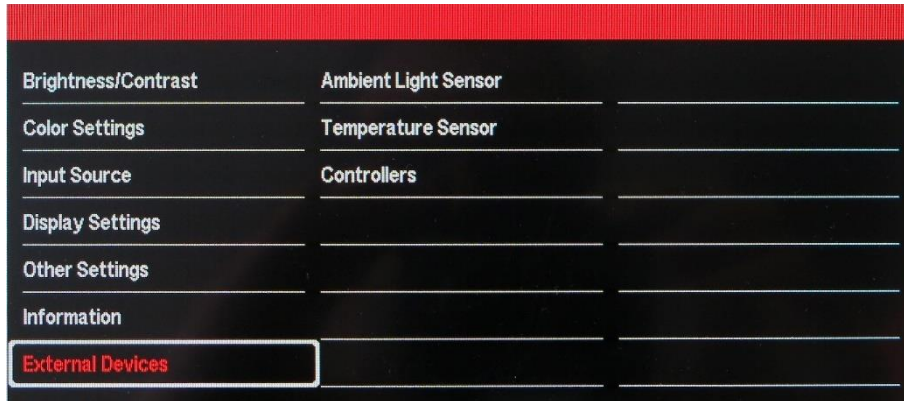

7.7.1 Submenu "Ambient Light Sensor":



Auto Brightness ON/Off: activates auto brightness function (available when optional [light sensor](#) is connected).

Br. Adjustment Interval[s]: sets the time of Brightness adjustment interval.

For more information and activation of detailed settings refer to "[Manual_For_ALS_And_Temperature_Sensor_Integration](#)" or contact Distec customer service.

7.7.2 Submenu “Temperature Sensor”:



Temp. Ctrl ON/Off: activates temperature control (available when optional [temperature sensor](#) is connected)
Current Temp [°C]: displays current temperature

For more information and activation of detailed settings refer to “[Manual_For_ALS_And_Temperature_Sensor_Integration](#)” or contact Distec customer service.

7.7.3 Submenu “Controllers”:

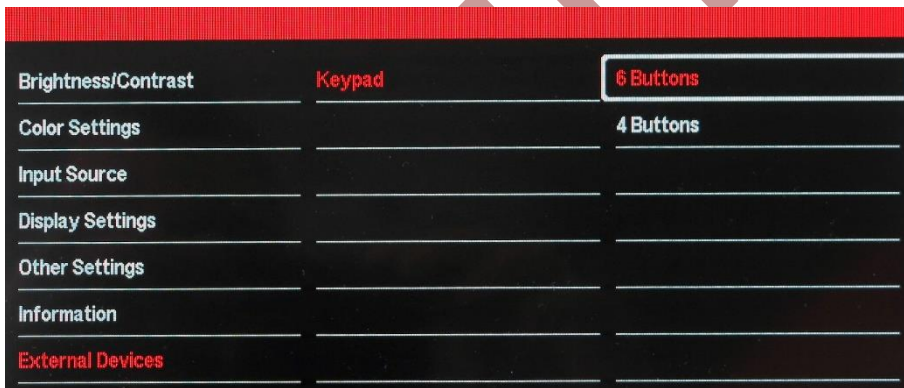

Keypad: switches between [4 Buttons](#) and 6 Buttons keypad.

7.8 Input Source Window

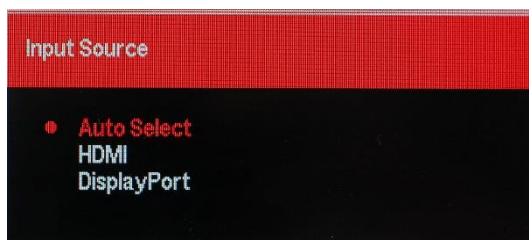

Select the input signal source without going into the main menu.

7.9 Volume Control

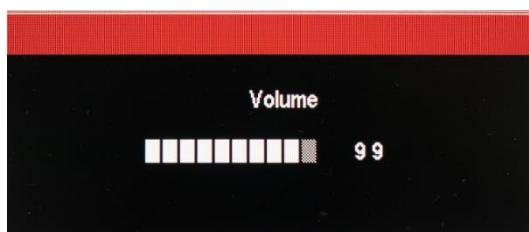

Controls the volume of the sound.

7.10 Brightness Control

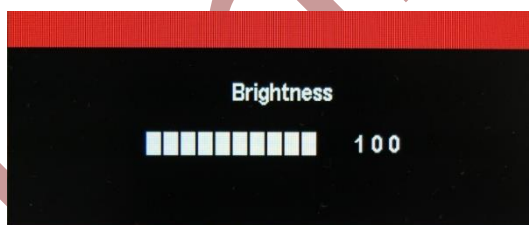

Controls the brightness of the display.

8 Supported Input Modes

The PrismaECOeDP-II can support the following input modes.

8.1 HDMI – Graphics

The PrismaECOeDP-II is equipped with the HDMI connector, CON11.

The factory preset supported input modes include:

Resolution	Resolution
640 x 480 @ 60 Hz (VESA)	1366 x 768 @ 60 Hz
800 x 600 @ 60 Hz (VESA)	1368 x 768 @ 60 Hz
1024 x 768 @ 60 Hz (VESA)	1600 x 1200 @ 60 Hz (VESA)
1280 x 768 @ 60 Hz	1920 x 1200 @ 60 Hz
1280 x 1024 @ 60 Hz (VESA)	1920 x 1080 @ 60 Hz
1360 x 768 @ 60 Hz	

8.2 HDMI – Video

The factory preset supported input modes include:

Resolution	Resolution
720 x 480 @ 60	1280 x 720 @ 60
720 x 576 @ 50	1920 x 1080 @ 50
1280 x 720 @ 50	1920 x 1080 @ 60

8.3 DisplayPort

The PrismaECOeDP-II is equipped with one DP connector, CON7.

The factory preset supported input modes include:

Resolution	Resolution
640 x 480 @ 60 Hz (VESA)	1366 x 768 @ 60 Hz
800 x 600 @ 60 Hz (VESA)	1368 x 768 @ 60 Hz
1024 x 768 @ 60 Hz (VESA)	1600 x 1200 @ 60 Hz (VESA)
1280 x 1024 @ 60 Hz (VESA)	1920 x 1200 @ 60 Hz
1360 x 768 @ 60 Hz	1920 x 1080 @ 60 Hz

Note that PrismaECOeDP-II is performing Source Detection according to DisplayPort 1.1a specification. If your source is not detected by PrismaECOeDP-II, please check if the pull-up and pull-down requirements for the AUX-channel are fulfilled:

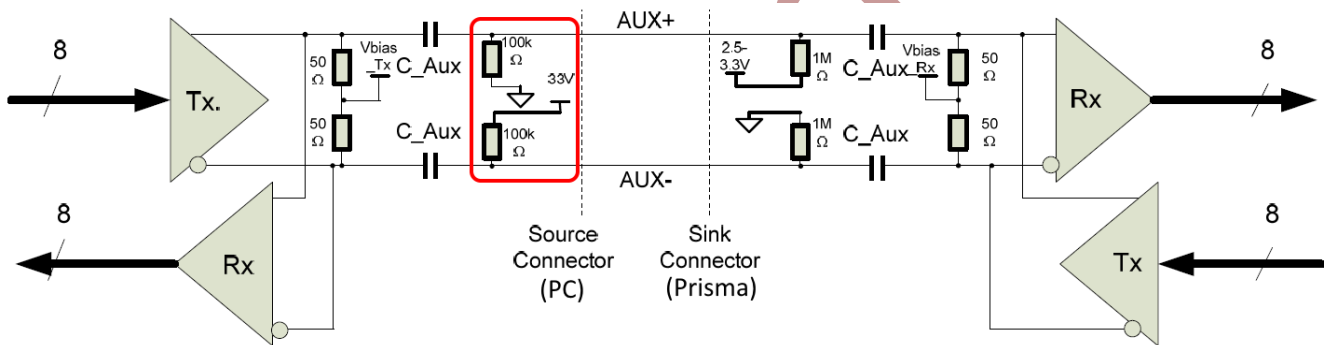

The DisplayPort Source Device must weakly pull down the AUX+ line and weakly pull up the AUX- line with 100kΩ (+/-5%) resistors between the AC-coupling capacitor and the Source Connector to assist detection of DisplayPort Source and Powered DisplayPort Source by the Sink Device.

(VESA DisplayPort Standard, Version 1, Revision 1a, January 11, 2008, chapter 3.4)

9 Absolute Maximum Ratings

Item	Symbol	Min.	Max.	Unit	Note
Supply Voltage (PR-02-195)	$V_{in (+12V)}$	0	18	VDC	1, 2, 3
Supply Voltage (PR-02-196)	$V_{in (+24V)}$	0	32	VDC	1, 2, 3
Storage Temperature	T_{St}	-35	+85	°C	
Operating Temperature	T_{Op}	-20	+70	°C	

Note (1) Within operating temperature range.

Note (2) Supply voltage limits are for the PrismaECOeDP-II, panel and backlight converter supply limits must be met as well, if the panel voltage is 12V and the converter is to be powered through the PrismaECOeDP-II board.

Note (3) Permanent damage to the device may occur if maximum values are exceeded.

10 Electrical Characteristics

All measurements done at 25°C ambient temperature.

Item	Condition	MIN.	TYP.	MAX.	Unit	Note
Supply Voltage (PR-02-195)		11	12.0	13	VDC	1
Supply Voltage (PR-02-196)		20	24.0	28	VDC	1
Current Consumption Board only (PR-02-196)	Full-HD input on HDMI	-	TBD	-	mA	2
	Sleep mode (no sync)	-	TBD	-		
	Power off mode	-	TBD	-		
Current Consumption Board only (PR-02-196)	Full-HD input on HDMI	-	TBD	-	mA	3
	Sleep mode (no sync)	-	TBD	-		
	Power off mode	-	TBD	-		
Maximum Panel Current	3.3V	-	-	1.5	A	
Maximum Backlight Current	12V	-	-	1.5	A	4

Note (1) Supply voltage limits are for the PrismaECOeDP-II, backlight converter supply limits must be met as well if the converter is to be powered through the PrismaECOeDP-II board.

Note (2) Measured with 12V input voltage.

Note (3) Measured with 24V input voltage.

Note (4) 12V is not regulated on PrismaECOeDP-II (12V version PR-02-196)

11 Mechanical Dimensions

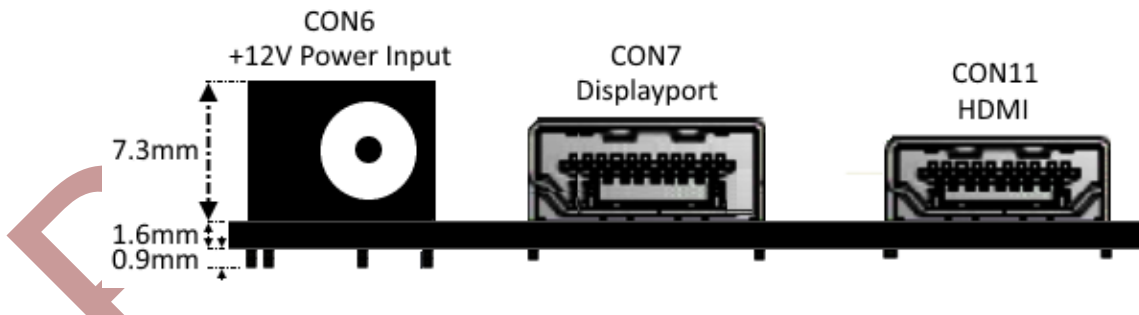
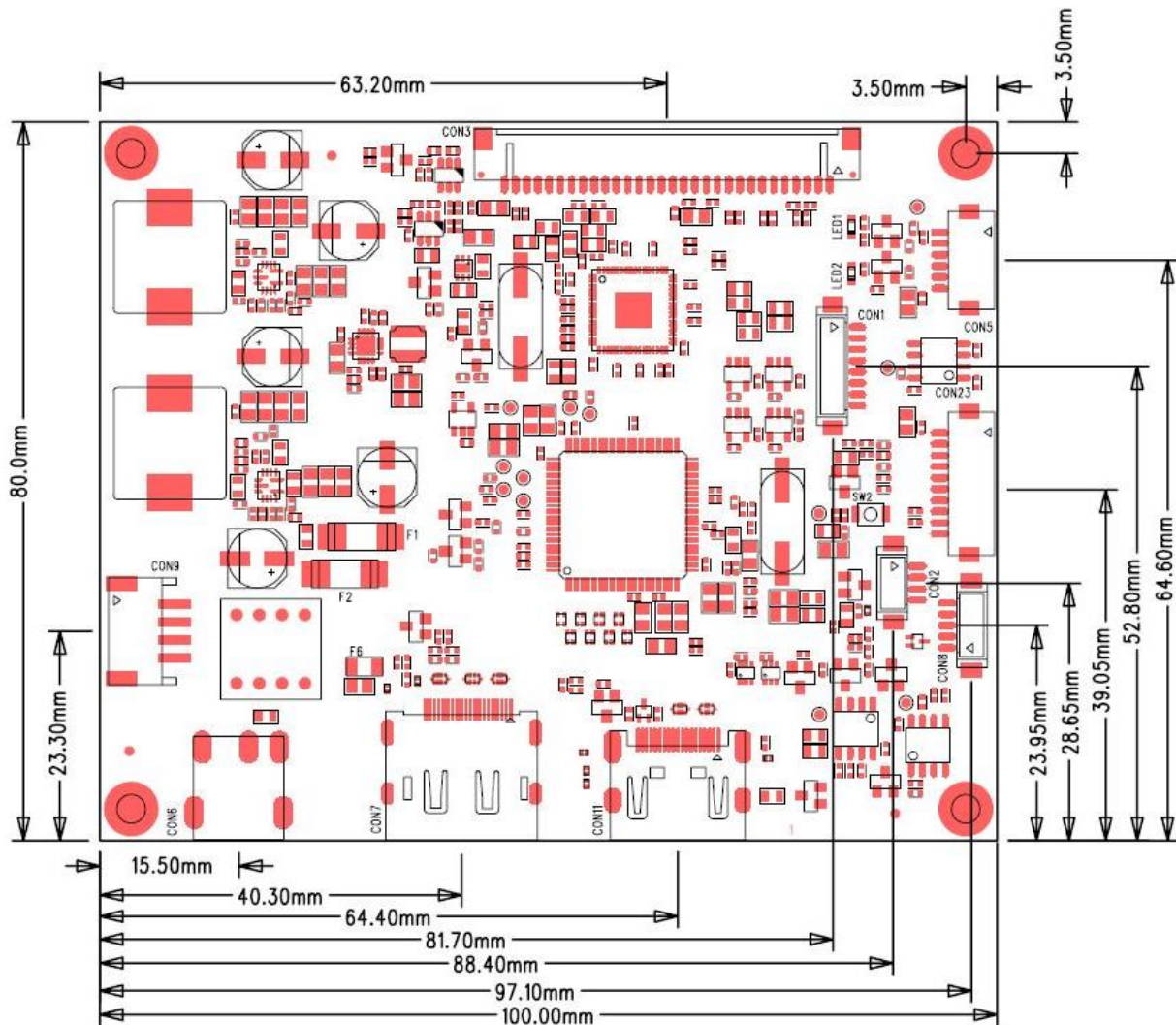

ITEM	DESCRIPTION	REMARKS
Length	100.0mm	± 0.2mm
Width	80.0mm	± 0.5mm
Height (top side)	7.3mm	± 0.2mm
Height (PCB)	1.6 mm	± 0.2 mm
Height (bottom side)	0.9 mm	± 0.1mm
Weight	TBD	

12 Connector Overview

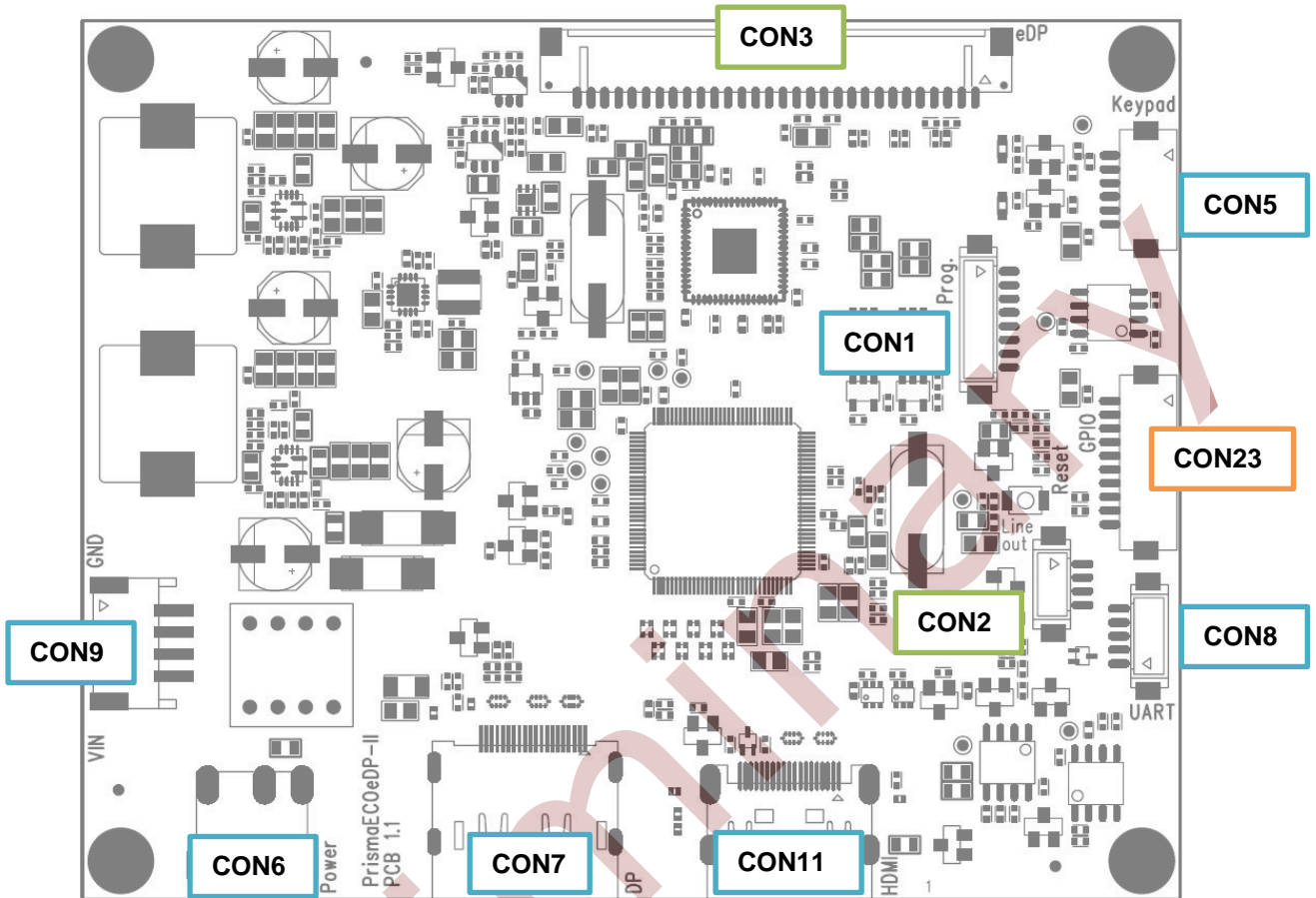

Connectors	Description	Type (Ref only)	Manufacture (Ref only)
CON1	SPI Programming Header	DF13-8P-1.25V (20)	Hirose
CON2	Audio Line Out	DF13-4P-1.25V	Hirose
CON3	eDP Output	DF14-30P-1.25H	Hirose
CON5	OSD-Control (Keypad)	DF13-6P-1.25H	Hirose
CON6	DC Power Jack (5A)	PJ-051AH	CUI Incorporated
CON7	DisplayPort Input	3660HF1R	Nexus
CON8	UART/GProbe	DF13-5P-1.25V	Hirose
CON9	DC Power Connector	S4B-PH-SM3-TB	JST
CON11	HDMI-Input	3600HFR	Nexus
CON23	External GPIO/I2C	DF13-10P-1.25H	Hirose

13 Input Connectors

Note: Pin 1 of connectors are clearly marked on silkscreen of PCB

SPI PROGRAMMING HEADER - CON1		
Pin	Signal	Description
1	SPI_PROG_EN#	Enable Signal
2	SPI_CLK_FLASH	SPI Clock
3	SPI_SI_FLASH	SPI_SI
4	SPI_SO_FLASH	SPI_SO
5	SPI_CS_FLASH	SPI_CS
6	MSTAR_RESET_N	MSTAR_RESET_N
7	GND	GND
8	+3.3V Output	+3.3V Output

OSD Control - CON5		
Pin	Signal	Description
1	KEYPAD_IN	Keypad Input Signal (Analog)
2	GND	Ground
3	LED_RED	Status LED – Red (Sleep Mode)
4	LED_GREEN	Status LED – Green (Signal good or searching for signal)
5	GND	Ground
6	+3.3V	+3.3V power

Power Supply - CON6		
Pin	Signal	Description
Center	+12V	12V Power supply (up to 5A)
Bottom	GND	Ground

UART - CON8		
Pin	Signal	Description
1	TX	Serial Output
2	RX	Serial Input
3	+3.3V	3.3V Power supply
4	NC	Not Connected
5	GND	Ground

DisplayPort Input – CON7		
Pin	Signal	Description
1	DP3-_IN	Pair-3 negative
2	GND	Ground
3	DP3+_IN	Pair-3 positive
4	DP2-_IN	Pair-2 negative
5	GND	Ground
6	DP2+_IN	Pair-2 positive
7	DP1-_IN	Pair-1 negative
8	GND	Ground
9	DP1+_IN	Pair-1 positive
10	DP0-_IN	Pair-0 negative
11	GND	Ground
12	DP0+_IN	Pair-0 positive
13	GND	Ground
14	GND	Ground
15	DPA+_IN	Aux channel positive
16	GND	Ground
17	DPA-_IN	Aux channel negative
18	HPD	Hot Plug Detect
19	Power Return	Return for +3.3V
20	+3.3V_DP	DisplayPort +3.3V

DC Power Connector - CON9		
Pin	Signal	Description
1	GND	Ground
2	GND	Ground
3	+12V	12V Power Supply
4	+12V	12V Power Supply

HDMI - CON11		
Pin	Signal	Description
1	TMDS2+	Differential TMDS Data 2+
2	GND	Ground
3	TMDS2-	Differential TMDS Data 2-
4	TMDS1+	Differential TMDS Data 1+
5	GND	Ground
6	TMDS1-	Differential TMDS Data 1-
7	TMDS0+	Differential TMDS Data 0+
8	GND	Ground
9	TMDS0-	Differential TMDS Data 0-
10	TMDSCLK+	Differential TMDS Clock+
11	GND	Ground
12	TMDSCLK-	Differential TMDS Clock-
13	CEC	Consumer Electronic Control
14	Reserved	
15	HDMI_SCL	DDC Clock
16	HDMI_SDA	DDC Data
17	GND	Ground
18	HDMI_VCC	+5V
19	Hot Plug	Hot Plug Detection

14 Output Connectors

Note: Pin 1 of connectors are clearly marked on silkscreen of PCB

Audio Line Out - CON2		
Pin	Signal	Description
1	GND	Ground
2	LINE_OUT_R	Audio Line out Left channel
3	LINE_OUT_L	Audio Line out Right channel
4	AUDIO_LINEOUT_MUTE	Mute Output (Level TBD)

eDP Output - CON3		
Pin	Signal	Description
1	NC	Not Connected
2	GND	Ground
3	DPAUX+	eDP Aux Channel +
4	DPAUX-	eDP Aux Channel -
5	GND	Ground
6	DP0-	eDP Channel 0 -
7	DP0+	eDP Channel 0 +
8	GND	Ground
9	DP1-	eDP Channel 1 -
10	DP1+	eDP Channel 1 +
11	GND	Ground
12	SVCC	+3.3V Panel Power Supply Output, max. 1.5A
13		
14	NC	Not Connected
15	GND	Ground
16		
17	HPD	Hot Plug Detection - Input
18	GND	Ground
19		
20		
21		
22	BKLT_EN	Backlight Enable - Output
23	BRT_ADJ	Backlight Dimming - PWM Output
24	NC	Not Connected
25	NC	Not Connected
26	+12V_BKLT	+12V Backlight Power Supply Output, max. 1.5A
27		
28		
29		
30	NC	Not Connected

15 I/O Connector

There are four GPIOs and one GPO with 4.75kOhm pull-ups connected to CON23. Note that these pins are used as bootstraps for the scaler chip, therefore make sure not to pull-down these pins during power up of PrismaECOeDP-II.

CON23 also provides an I2C interface to control external I2C devices.

External GPIO / I2C - CON23		
Pin	Signal	Description
1	+3.3V	3.3V power supply
2	EXT_GPO_4	External GPO 4 (output only)
3	EXT_GPIO_0	External GPIO 0
4	EXT_GPIO_1	External GPIO 1
5	EXT_GPIO_2	External GPIO 2
6	EXT_GPIO_3	External GPIO 3
7	NC	No Connection
8	SCL	I2C Clock
9	SDA	I2C Data
10	GND	Ground

16 Supported Panels and Backlight Converter

PrismaECOeDP-II supports single and dual lane eDP panels up to a resolution of 1920x1200@60Hz.

Panel and Backlight Options	Hardware-Options
Panel Voltage (CON3, SVCC)	3.3V
Pixel Per Clock	1
	2
Backlight Voltage (CON3, +12V_BKLT)	12V
Backlight Control Type	PWM
Voltage Level of PWM Signal (CON3, BRT_ADJ)	3.3V
Voltage Level of Backlight Enable Signal (CON3, BKLT_EN)	3.3V

17 Hardware Information

Part Number	Product	Description	Status
PR-02-195	PrismaECOeDP-II-00-12	Variant A: DC-Input: 12V	Active
PR-02-196	PrismaECOeDP-II-01-24	Variant B: DC-Input: 24V	Active

18 Accessories

18.1 Light Sensor ZU-02-412

This light sensor can be connected to the scaler chip to automatically adjust the panel brightness according to the ambient light.

Fitting cable to CON23: **KA-31-037**.



18.2 Temperature Sensor ZU-02-389

A temperature sensor is available to check the temperature of a TFT panel or any other hardware. FW support is provided upon request.

Fitting cable to CON23: **TBD**

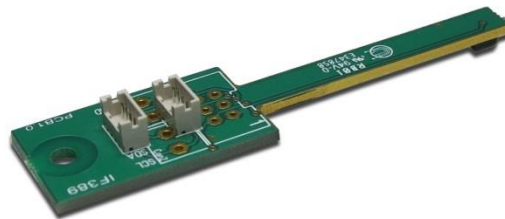

Remark: When both light and temperature sensors are used, please connect light sensor ZU-02-412 directly to temperature sensor ZU-02-389 via cable: **KA-30-959**

18.3 Frozen Screen Detector ZU-02-512

A Frozen-Screen Detector can be connected to CON10. This feature can detect if the content of the display is being updated.

FW support is provided upon request. Also refer to datasheet and technical details for this feature. Please contact Distec customer service if you need more information.

Fitting cable to CON23: **KA-31-037**



19 Programming, configuration and ROSD via serial port

Preconfigured (“ready to run”) HW is also available, please contact customer service for information.

Please refer to MStarRover Manual for details of configuration.

- If PrismaECOeDP-II is blank and without any Firmware the DediProg SF100 SPI programmer is mandatory for initial flashing of Firmware. After that Firmware can be flashed also via Serial/USB Port.
- For configuration of Display settings/EDID configuration or for usage of ROSD its sufficient to use the USB to Serial UART Converter IF430.

19.1 HW requirements

- Standard PC with Windows OS
- 1x USB port for serial programmer
- 1x USB port for DediProg SF100 SPI programmer
-

DediProg SF100 SPI Programmer (optional) *		
Part#	Part description	Additional info
KI-90-035**	DediProg SF100 USB-SPI Programmer	
KI-90-035**	ZU-02-399 IF399-00-SPI Buffer interface for PIIIA	
KI-90-035**	KA-30-377 Cable SPI-Buffer-Interface 8pol. 150mm	Cable between SPI Buffer CON1 and SPI connector CON1

- (*) mandatory for initial FW-flashing of blank PrismaECOeDP-II
- (**) KI-90-035 consists of DediProg SF100 USB-SPI Programmer, buffer interface and cable (as shown below).

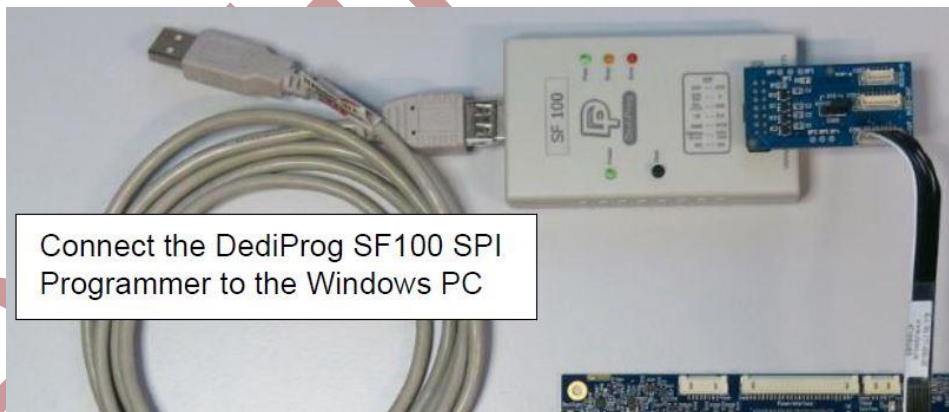

USB to serial adapter		
Part#	Part description	Additional info
ZU-02-430	IF430-00 USB to Serial UART Converter	RS232 programming adapter
KA-30-101	Cable Service & Remote 80cm	Cable from RS-232 adapter to PrismaECOeDP-II (CON8)
KA-30-051	USB-Cable, Highspeed, type A/B m/m 2m	



Our company network supports you worldwide with offices in Germany, Austria, Switzerland, the UK and the USA. For more information please contact:

Headquarters

Germany



FORTEC Elektronik AG

Augsburger Str. 2b
82110 Germering

Phone: +49 89 894450-0
E-Mail: info@fortecaq.de
Internet: www.fortecaq.de

Fortec Group Members

Austria



Distec GmbH Office Vienna

Nuschinggasse 12
1230 Wien

Phone: +43 1 8673492-0
E-Mail: info@distec.de
Internet: www.distec.de

Germany



Distec GmbH

Augsburger Str. 2b
82110 Germering

Phone: +49 89 894363-0
E-Mail: info@distec.de
Internet: www.distec.de

Switzerland



ALTRAC AG

Bahnhofstraße 3
5436 Würenlos

Phone: +41 44 7446111
E-Mail: info@altrac.ch
Internet: www.altrac.ch

United Kingdom



Display Technology Ltd.

Osprey House, 1 Osprey Court
Hinchingsbrooke Business Park
Huntingdon, Cambridgeshire, PE29 6FN

Phone: +44 1480 411600
E-Mail: info@displaytechnology.co.uk
Internet: www.displaytechnology.co.uk

USA



Apollo Display Technologies, Corp.

87 Raynor Avenue, Unit 1
Ronkonkoma, NY 11779

Phone: +1 631 5804360
E-Mail: info@apolloDisplays.com
Internet: www.apolloDisplays.com