

# Datasheet

## PrismaMINI-HDMI-DP

### HDMI, DP to 18/24-bit dual/single LVDS

PR-01-430\_A1

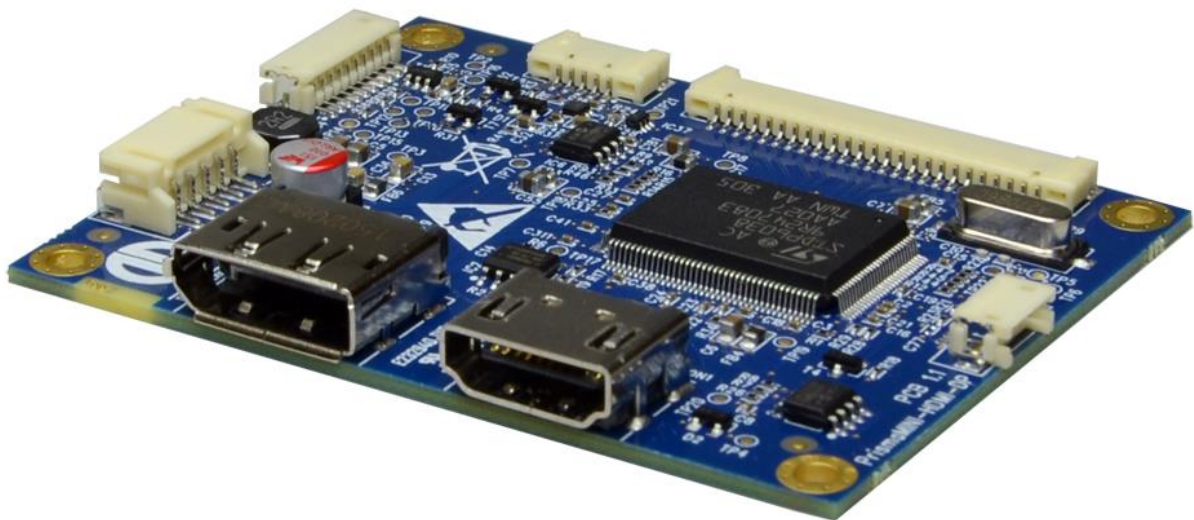

Version 1.4

**27.07.2017**

The information contained in this document has been carefully researched and is, to the best of our knowledge, accurate. However, we assume no liability for any product failures or damages, immediate or consequential, resulting from the use of the information provided herein. Our products are not intended for use in systems in which failures of product could result in personal injury. All trademarks mentioned herein are property of their respective owners. All specifications are subject to change without notice.



## Table of Contents

Revision History .....	3
1 Overview.....	4
2 Input .....	4
3 Output .....	5
4 Features .....	5
5 Power Concept.....	5
6 Electrical Characteristics .....	6
7 Absolute Maximum Ratings.....	6
8 Connector Overview .....	7
9 CON1 – HDMI CONNECTOR .....	8
10 CON2 – DisplayPort CONNECTOR.....	9
11 CON3 – Power CONNECTOR .....	9
12 CON4 – Backlight power supply CONNECTOR .....	10
13 CON5 – LVDS Power & Option CONNECTOR .....	10
14 CON6 – LVDS 18/24-bit single/dual CONNECTOR.....	11
15 CON7 – UART CONNECTOR .....	12
16 Supported Panels and Backlights (Inverter/Converter) .....	12
17 Mechanical Dimensions .....	13
18 Hardware Information.....	14
19 Reference KIT .....	14



## Revision History

Date	Rev.No.	Description	Page
16.11.2016	1.0	Initial version	All
11.05.2017	1.1	Added RS232 connection picture	15
		Added Ordering Information	16
		Removed chapter 19 news and Updates	16
22.05.2017	1.2	Added Chapter 16 Supported Panels and Backlights	14
23.05.2017	1.3	Removed all Panel ordering Codes	5, 6
		Changed Chapter 18 Ordering Information to Hardware Information	16
27.07.2017	1.4	Added Reference to the remote OSD control description	12



## 1 Overview

PrismaMINI-HDMI-DP is Data Display Group's new TFT-Controller board based on the STDP6038 (Chandler) graphic-chip. It is a cost efficient solution designed for cost sensitive applications up to 1920x1200 and no need for different inputs or other additional functionalities. PrismaMINI-HDMI-DP is focused on the essential: one panel – and two input types.

## 2 Input

PrismaMINI-HDMI-DP has DisplayPort and HDMI input connections because of its wide adoption in industrial and consumer markets.

STDP6038 (Chandler) chip has an ultra-reliable HDMI 1.4 and DP receiver

Other key features are

- Single Link TMDS Rx for up to 12-bit 1080p
- Captures up to 225MHz
- Direct connect to all DP compliant transmitters
- DisplayPort 1.1a
- Direct connect to all HDMI compliant TMDS transmitters
- HDCP
- No CEC

Supported Input Resolutions
640 x 480 @ 60 Hz (VESA)
800 x 600 @ 60 Hz (VESA)
720 x 480 @ 60 Hz (Video)
720 x 576 @ 50 Hz (Video)
1024 x 768 @ 60 Hz (VESA)
1280 x 720 @ 50 Hz (Video)
1280 x 720 @ 60 Hz (Video)
1280 x 768 @ 60 Hz
1280 x 1024 @ 60 Hz (VESA)
1360 x 768 @ 60 Hz
1366 x 768 @ 60 Hz
1368 x 768 @ 60 Hz
1600 x 1200 @ 60 Hz (VESA)
1920 x 1080 @ 50 Hz (Video)
1920 x 1080 @ 60 Hz
1920 x 1200 @ 60 Hz



## 3 Output

PrismaMINI-HDMI-DP has LVDS 18/24-bit single/dual channel output. To simplify installation one connector is used for panel and another connector is used for backlight. Brightness is controlled by PWM signal V\_BRT\_ADJ. The default value can be changed over serial port or by firmware update.

## 4 Features

- No OSD menu usability due to no buttons, but full remote control OSD (all commands; please request command set file)
- Remote control via RS-232 interface (TTL level)
- Firmware update over serial port
- Brightness controlled by PWM
- Other versions: PrismaMINI-H (HDMI)
- VCC Wide range voltage input from 3.3V to 12V

## 5 Power Concept

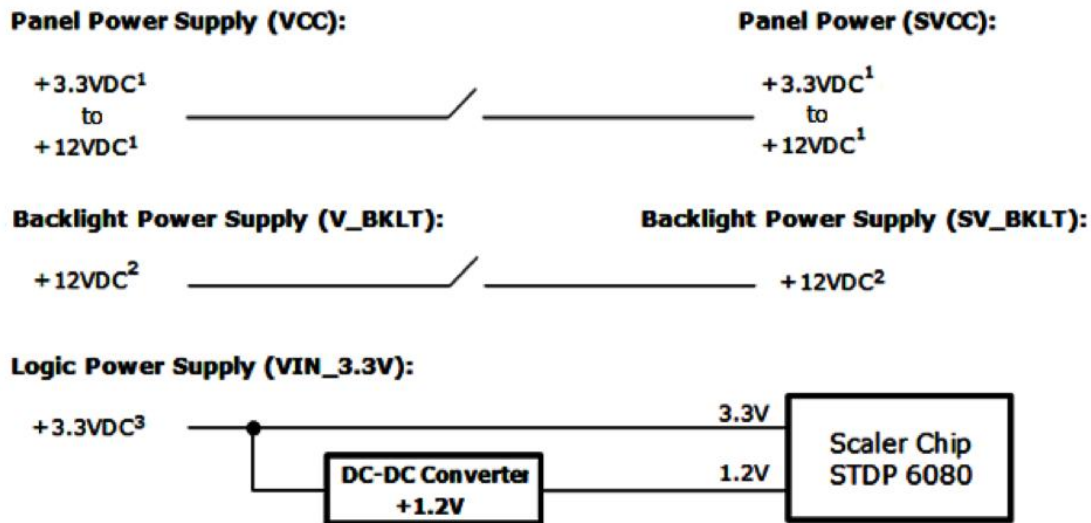

### (1) Panel Power Supply (VCC):

The Panel Power Supply Input (VCC) is switched through to the Panel SVCC by an MOSFET with the maximal RDS(ON) of 54mOhm. The recommended voltage range must be checked in the Datasheet of the Panel manufacturer.

### (2) Backlight Power Supply (V\_BKLT):

The Backlight Power Supply Input (V\_BKLT) is switched through to the Backlight Power Supply Output (SV\_BKLT) by an MOSFET with the maximal RDS(ON) of 60mOhm. Please refer to the panel datasheet regarding the input voltage range.

### (3) Logic Power Supply VIN\_3.3V:

The Scaler Chip STDP 6080 works with the operating Logic Power Supply (VIN\_3.3V).



## 6 Electrical Characteristics

All measurements done at 25°C ambient temperature.

DESCRIPTION	Condition	MIN.	TYP.	MAX.	Unit	Note
Backlight Power Supply (V_BKLT)		11.7	12.0	13.0	VDC	(1)
Logic Power Supply (VIN_3.3V)		3.15	3.3	3.45	VDC	(2)
Panel Power Supply Input (VCC)		3.2	3.3, 5.0, 12.0	13.0	VDC	(3)
Current Consumption (V_BKLT)	Board Only (12V)	1.2	1.5	5	mA	-
Current Consumption (VCC)	Board Only	0.3 0.5 1.2	0.4 (3.3V) 0.6 (5V) 1.3 (12V)	5	mA	-
Current Consumption (VIN_3.3V)	Board Only (3.3V)	240	280	400	mA	-

**Note (1):** Backlight Power Supply: The Backlight Power Supply Input (V\_BKLT) is switched through to the Backlight Power Supply Output (SV\_BKLT) by an MOSFET with the maximal RDS(ON) of 60mOhm. Please refer to the panel datasheet regarding the input voltage range.

**Note (2):** The Scaler Chip STDP 6080 works with the operating Logic Power Supply (VIN\_3.3V).

**Note (3):** Panel Power Supply Input (VCC): The recommended voltage range must be checked in the Datasheet of the Panel manufacturer. The Panel Power Supply Input (VCC) is switched through to the Panel SVCC by an MOSFET with the maximal RDS(ON) of 54mOhm.

## 7 Absolute Maximum Ratings

DESCRIPTION	Signal	Min.	Max.	Unit	Note
Backlight Power Supply	V_BKLT	0	14	VDC	1, 2, 3, 4
Permissible Backlight Current	IV_BKLT	0	2	A	1, 2, 3, 4
Logic Power Supply	VIN_3.3V	0	3.6	VDC	1, 2, 3
Panel Power Supply (VCC)	VCC	0	14	VDC	1, 2, 3, 4
Permissible Panel Current	IVCC	-	1.5	A	1, 2, 3, 4
Storage Temperature	TST	-35	+85	°C	
Operating Temperature	TOP	-20	+85	°C	

**Note (1):** Within operating temperature range.

**Note (2):** Supply voltage limits are for the PrismaMINI-HDMI-DP.

**Note (3):** Permanent damage to the device may occur if maximum values are exceeded.

**Note (4):** Please refer to the panel datasheet for recommended voltage range.



## 8 Connector Overview

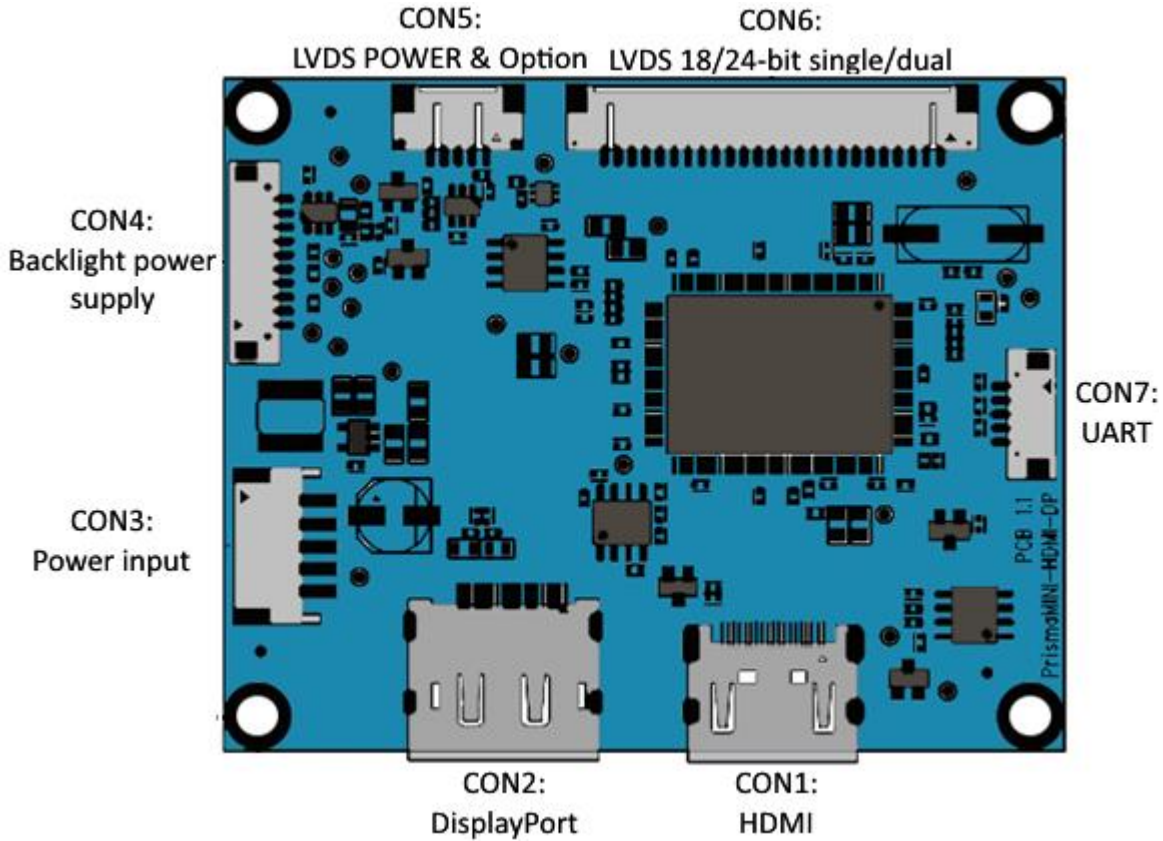

Connector	DESCRIPTION	TYPE	MANUFACTURER
CON1	HDMI	3600HFR	Nexus
CON2	DisplayPort	3660HF1R	Nexus
CON3	Power input	S5B-PH-SM4-TB(LF)(SN)	JST
CON4	Backlight power supply	DF13-10P-1.25H	Hirose
CON5	LVDS Power & Option	DF14-5P-1.25H	Hirose
CON6	LVDS 18/24-bit single/dual output	DF14-25P-1.25H	Hirose
CON7	UART	DF13-5P-1.25H	Hirose



## 9 CON1 – HDMI CONNECTOR

HDMI CONNECTOR – CON1		
Pin	Signal	Description
1	TMDS2+	Differential TMDS Data 2+
2	GND	Ground
3	TMDS2-	Differential TMDS Data 2-
4	TMDS1+	Differential TMDS Data 1+
5	GND	Ground
6	TMDS1-	Differential TMDS Data 1-
7	TMDS0+	Differential TMDS Data 0+
8	GND	Ground
9	TMDS0-	Differential TMDS Data 0-
10	TMDSCLK+	Differential TMDS Clock+
11	GND	Ground
12	TMDSCLK-	Differential TMDS Clock-
13	CEC	Consumer Electronic Control
14	Reserved	
15	HDMI_SCL	DDC Clock
16	HDMI_SDA	DDC Data
17	GND	Ground
18	HDMI_VCC	+5V
19	Hot Plug	Hot Plug Detection





## 10 C0N2 – DisplayPort CONNECTOR

DisplayPort CONNECTOR – C0N2		
Pin	Signal	Description
1	DP3-_INs	Pair-3 negative
2	GND	Ground
3	DP3+_IN	Pair-3 positive
4	DP2-_IN	Pair-2 negative
5	GND	Ground
6	DP2+_IN	Pair-2 positive
7	DP1-_IN	Pair-1 negative
8	GND	Ground
9	DP1+_IN	Pair-1 positive
10	DP0-_IN	Pair-0 negative
11	GND	Ground
12	DP0+_IN	Pair-0 positive
13	GND	Ground
14	GND	Ground
15	DPA+_IN	Aux channel positive
16	GND	Ground
17	DPA-_IN	Aux channel negative
18	HPD	Hot Plug Detect
19	Power Return	Return for +3.3V
20	+3.3V_DP	DisplayPort +3.3V

## 11 C0N3 – Power CONNECTOR

POWER CONNECTOR– C0N3		
Pin	Signal	Description
1	V_BKLT	Backlight Power Supply +12V
2	GND	Ground
3		
4	VIN_3.3V	Logic Power Supply +3.3V
5	VCC	Panel Power Supply Input (Voltage Level +3.3V, 5V or 12V)



## 12 C0N4 – Backlight power supply CONNECTOR

Backlight power supply CONNECTOR – C0N4		
Pin	Signal	Description
1	SV_BKLT	Backlight Power Supply +12V
2	GND	Ground
3	V_BKLT_EN	Backlight Enable (Voltage Level +3.3V)
4	V_BRT_ADJ	Brightness Dimming (PWM Level +3.3V)
5	GPIO	GPIO/M_I2C_SDA
6	GPIO	GPIO/M_I2C_SCL
7	SV_BKLT	Backlight Power Supply +12V
8	SV_BKLT	Backlight Power Supply +12V
9	GND	Ground
10	GND	Ground

## 13 C0N5 – LVDS Power & Option CONNECTOR

LVDS Power & Option – C0N5		
Pin	Signal	Description
1	LVDS_OPT	LVDS option pin selectable +3.3V H/L
2	SVCC	Panel Power Supply (Voltage Level +3.3V, 5V or 12V)
3	SVCC	Panel Power Supply (Voltage Level +3.3V, 5V or 12V)
4	GND	Ground
5	GND	Ground



## 14 CON6 – LVDS 18/24-bit single/dual CONNECTOR

LVDS 18/24-bit single/dual CONNECTOR – CON6		
Pin	Signal	Description
1	SVCC	Panel Power Supply (Voltage Level +3.3V, 5V or 12V)
2		
3	GND	Ground
4		
5	TXB3+	LVDS data 1st pixel
6	TXB3-	LVDS data 1st pixel
7	TXBCL+	LVDS clock 1st pixel
8	TXBCL-	LVDS clock 1st pixel
9	TXB2+	LVDS data 1st pixel
10	TXB2-	LVDS data 1st pixel
11	TXB1+	LVDS data 1st pixel
12	TXB1-	LVDS data 1st pixel
13	TXB0+	LVDS data 1st pixel
14	TXB0-	LVDS data 1st pixel
15	TXA3+	LVDS data 2nd pixel
16	TXA3-	LVDS data 2nd pixel
17	TXACL+	LVDS clock 2nd pixel
18	TXACL-	LVDS clock 2nd pixel
19	TXA2+	LVDS data 2nd pixel
20	TXA2-	LVDS data 2nd pixel
21	TXA1+	LVDS data 2nd pixel
22	TXA1-	LVDS data 2nd pixel
23	TXA0+	LVDS data 2nd pixel
24	TXA0-	LVDS data 2nd pixel
25	V_BKLT_EN	Backlight Enable (Voltage Level +3.3V)



## 15 CON7 – UART CONNECTOR

UART CONNECTOR- CON7		
Pin	Signal	Description
1	TX	Serial Output
2	RX	Serial Input
3	+3.3V	3.3V Power Supply
4	--	Not Connected
5	GND	Ground

Use CON7 together with cable KA-30-101 and ZU-02-370 to configure the board with the Data Display ChandlerRover software or to control the board via Remote OSD. Please refer to Remote\_OSD\_Description.doc for remote OSD-Control description.

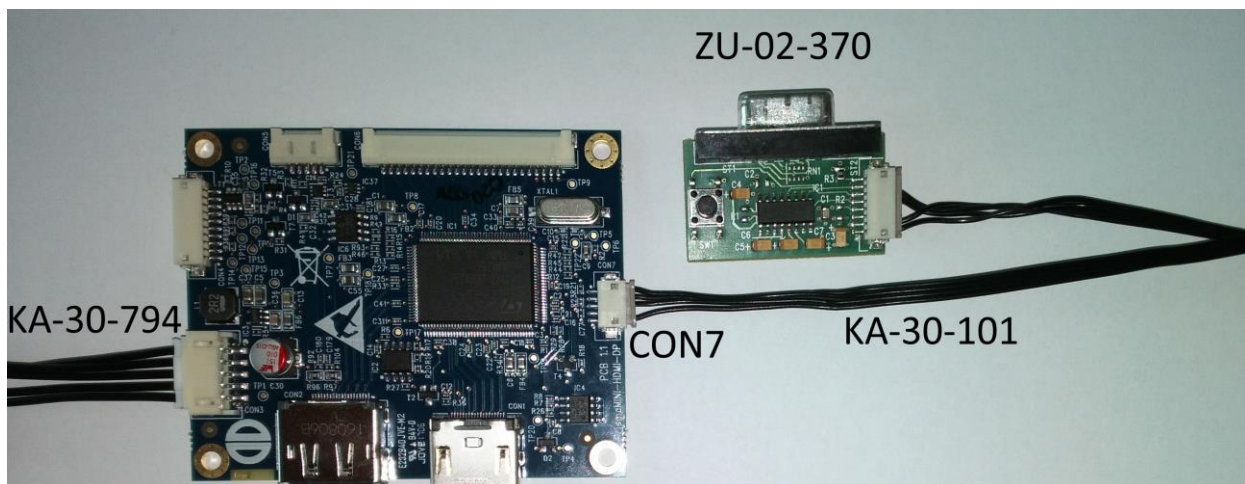

## 16 Supported Panels and Backlights (Inverter/Converter)

Panels and Backlights Options (Note 1)	Hardware Options
Panel Voltage (SVCC) (Note 1)	3,3V (Ext. Source)
	5V (Ext. Source)
	12V (Ext. Source)
Pixel Per Clock	1
	2
Option Pin 0 Voltage Level	0V
	3,3V
Backlight Voltage (SV_BKLT)	12V
Backlight Control Type	PWM
Voltage Level of PWM Signal (V_BRT_ADJ)	3,3V
Voltage Level of Backlight Enable Signal (V_BKLT_EN)	3,3V

**Note (1):** The Panel Power Supply Input (VCC) is switched through to the Panel SVCC.



## 17 Mechanical Dimensions

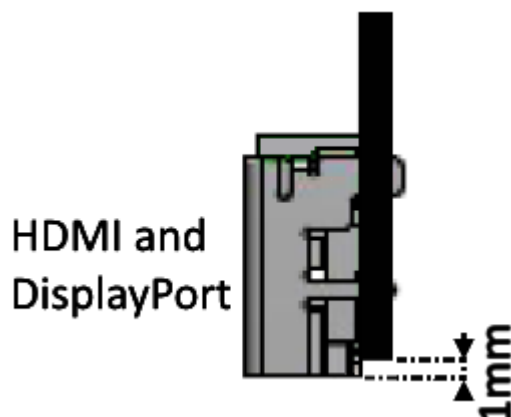
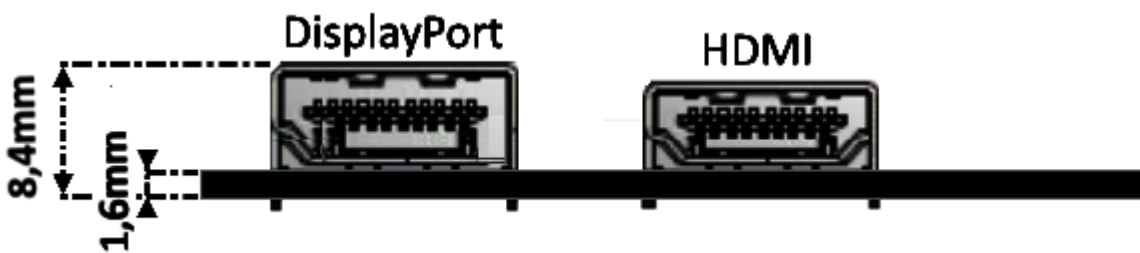
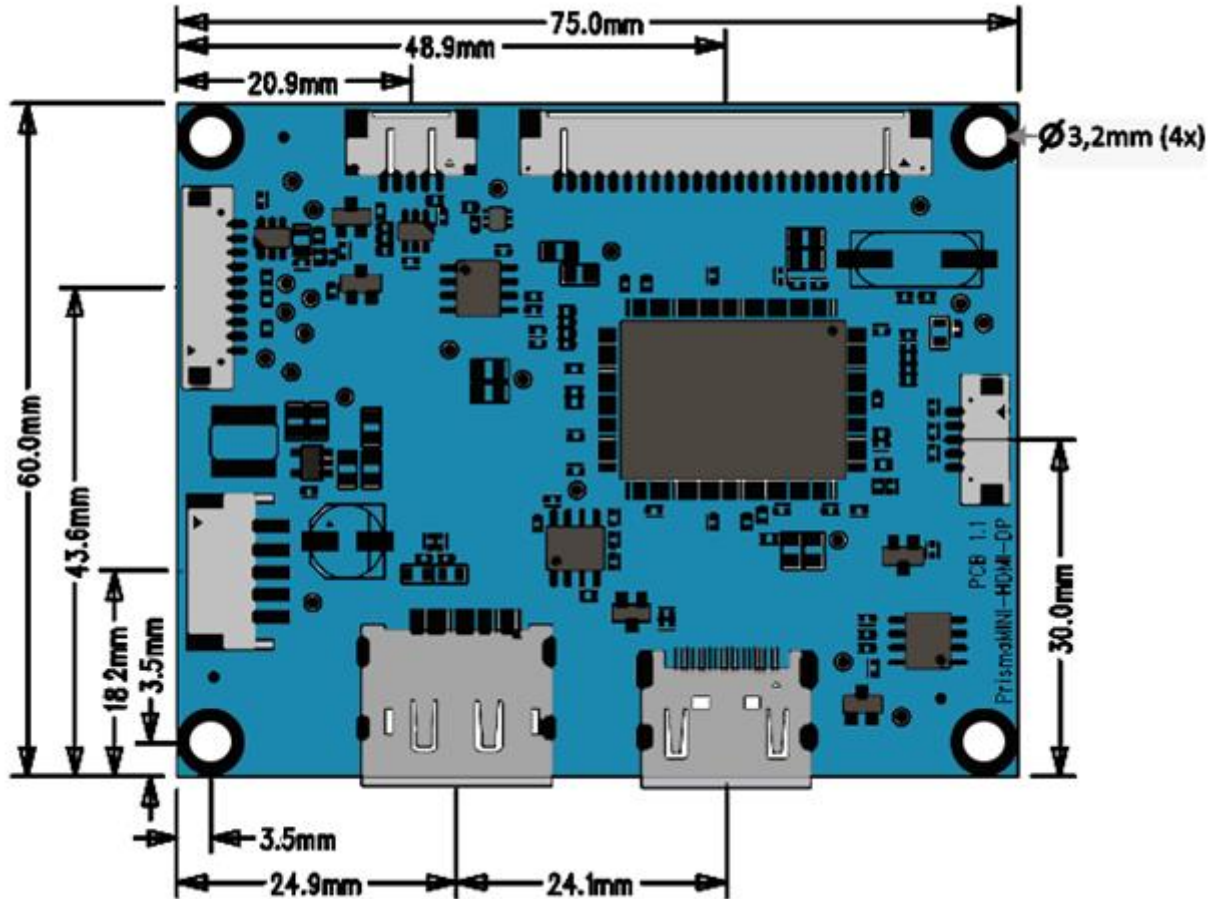



Item	Description	Remarks
Length	75 mm	± 0.2 mm
Width	60 mm	± 0.2 mm
Height	8.4 mm	+ 0.3 mm
Weight	31 g	

## 18 Hardware Information

Part Number	Description	Comment
PR-01-430_A1	HDMI, DP to 18/24-bit dual/single LVDS	
KA-30-794	PR-01-430_A1 Cable JST PHR-5/open end 500mm	
ZU-02-370	IF370-00-R10programming adap.Pris./Art.NET	optional
KA-30-101	Cable Service/Debug ArtistaNET/Pris 80cm	optional

## 19 Reference KIT

Reference Part Number	Description
KI-52-001	24,0 G240HW01V0/PrismaMINI-HDMI-DP

Our company network supports you worldwide with offices in Germany, Great Britain, Turkey and the USA.  
For more information please contact:



## DATA DISPLAY GROUP

A **FORTEC** GROUP MEMBER

### **Distec GmbH**

Augsburger Str. 2b  
82110 Germering  
Germany

Phone: +49 (0)89 / 89 43 63-0  
Fax: +49 (0)89 / 89 43 63-131  
E-Mail: [info@datadisplay-group.de](mailto:info@datadisplay-group.de)  
Internet: [www.datadisplay-group.de](http://www.datadisplay-group.de)

### **Display Technology Ltd.**

5 The Oaks Business Village  
Revenge Road, Lordswood  
Chatham, Kent, ME5 8LF  
United Kingdom  
Phone: +44 (0)1634 / 67 27 55  
Fax: +44 (0)1634 / 67 27 54  
E-Mail: [info@displaytechnology.co.uk](mailto:info@displaytechnology.co.uk)  
Internet: [www.datadisplay-group.com](http://www.datadisplay-group.com)

### **Sales Partner:**

### **DATA DISPLAY BİLİŞİM TEKNOLOJİLERİ İÇ VE DIŞ TİCARET LİMİTED ŞİRKETİ**

Barbaros Mh. Ak Zambak Sk. A Blok D:143  
34376 Ataşehir / Istanbul  
Turkey  
Phone: +90 (0)216 / 688 04 68  
Fax: +90 (0)216 / 688 04 69  
E-Mail: [info@data-display.com.tr](mailto:info@data-display.com.tr)  
Internet: [www.data-display.com.tr](http://www.data-display.com.tr)

### **FORTEC Elektronik AG**

Lechwiesenstr. 9  
86899 Landsberg am Lech  
Germany

Phone: +49 (0)8191 / 911 72-0  
Fax: +49 (0)8191 / 217 70  
E-Mail: [sales@fortecag.de](mailto:sales@fortecag.de)  
Internet: [www.fortecag.de](http://www.fortecag.de)

### **Apollo Display Technologies, Corp.**

87 Raynor Avenue,  
Unit 1 Ronkonkoma,  
NY 11779  
United States of America  
Phone: +1 631 / 580-43 60  
Fax: +1 631 / 580-43 70  
E-Mail: [info@apolloDisplays.com](mailto:info@apolloDisplays.com)  
Internet: [www.apolloDisplays.com](http://www.apolloDisplays.com)