



OUR GLOBAL  
COMPETENCE  
CENTRES

 APOLLO DISPLAY  
TECHNOLOGIES



 DISTEC



 DISPLAY  
TECHNOLOGY



# Datasheet

## InnoLux

**G1' ' ÷ 9-L0'**

CH-01-01 í

- Tentative Specification
- Preliminary Specification
- Approval Specification

MODEL NO.: G133IGE  
SUFFIX: L03

<b>Customer:</b>	
<b>APPROVED BY</b>	<b>SIGNATURE</b>
Name / Title _____	_____
Note	
<hr/> Please return 1 copy for your confirmation with your signature and comments.	

核准時間	部門	審核	角色	投票
2011-04-13 15:26:37	APPL 產品管理處	yuhsiang.chang (張喻翔/514-10922)	Director	Accept

- CONTENTS -

REVISION HISTORY	-----	3
1. GENERAL DESCRIPTION	-----	4
1.1 OVERVIEW		
1.2 FEATURES		
1.3 APPLICATION		
1.4 GENERAL SPECIFICATIONS		
1.5 MECHANICAL SPECIFICATIONS		
2. ABSOLUTE MAXIMUM RATINGS	-----	6
2.1 ABSOLUTE RATINGS OF ENVIRONMENT		
2.2 ELECTRICAL ABSOLUTE RATINGS		
2.2.1 TFT LCD MODULE		
2.2.2 LED CONVERTER		
3. ELECTRICAL CHARACTERISTICS	-----	8
3.1 RECOMMENDED OPERATING CONDITION		
3.2 BACKLIGHT UNIT		
4. BLOCK DIAGRAM	-----	11
4.1 TFT LCD MODULE		
5. INPUT TERMINAL PIN ASSIGNMENT	-----	12
5.1 LVDS I/O PIN ASSIGNMENT		
5.2 BACKLIGHT PIN ASSIGNMENT		
5.3 TIMING DIAGRAM OF LVDS INPUT SIGNAL		
5.4 COLOR DATA INPUT ASSIGNMENT		
6. INTERFACE TIMING	-----	16
6.1 TIMING CHARACTERISTICS		
6.2 POWER ON/OFF SEQUENCE		
7. OPTICAL CHARACTERISTICS	-----	18
7.1 TEST CONDITIONS		
7.2 OPTICAL SPECIFICATIONS		
8. RELIABILITY TEST	-----	21
8.1 RELIABILITY TEST CONDITION		
9. PACKAGING	-----	22
9.1 PACKING SPECIFICATION		
9.2 PACKING METHOD		
10. DEFINITION OF LABEL	-----	24
10.1 CMI MODULE LABEL		
11. PRECAUTIONS	-----	25
11.1 ASSEMBLY AND HANDLING PRECAUTIONS		
11.2 SAFETY PRECAUTIONS		
12. MECHANICAL CHARACTERISTICS	-----	26

**REVISION HISTORY**

Version	Date	Section	Description
Ver 1.0	Apr. 6, '11	All	G133IGE-L03 Preliminary specification was first issued.

1. GENERAL DESCRIPTION

1.1 OVERVIEW

G133IGE-L03 is a 13.3" TFT Liquid Crystal Display module and 20 pins LVDS interface. This module supports 1280 x 800 WXGA mode and can display 262K or 16.2M colors. The converter circuit for LED is built in.

1.2 FEATURES

- WXGA (1280 x 800 pixels) resolution
- LVDS (Low Voltage Differential Signaling) interface
- LED light source

1.3 APPLICATION

- Industry Application

1.4 GENERAL SPECIFICATIONS

Item	Specification	Unit	Note
Diagonal Size	13.3	inch	
Active Area	286.08 x 178.8	mm	(1)
Bezel Opening Area	289.1 x 181.8	mm	
Driver Element	a-si TFT active matrix	-	-
Pixel Number	1280 x R.G.B. x 800	pixel	-
Pixel Pitch	0.2235 x 0.2235	mm	-
Pixel Arrangement	RGB vertical stripe	-	(2)
Display Colors	262k or 16.2M	color	-
Display Mode	Normally White	-	-
Surface Treatment	Anti-glare, Hard Coating ( 3H )	-	-
Module Power Consumption	(6.5)	W	Typ.

Note (1) Please refer to the attached drawings for more information of front and back outline dimensions.

Note (2)

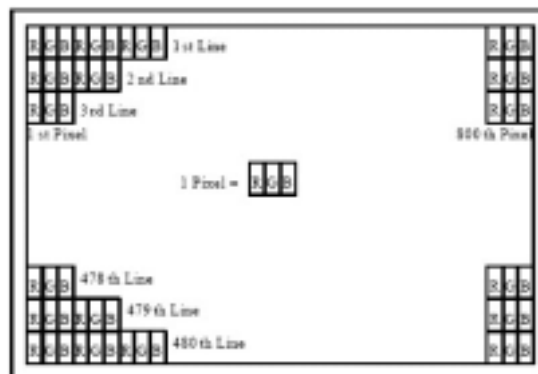

1.5 MECHANICAL SPECIFICATIONS

Item		Min.	Typ.	Max.	Unit	Note
Module Size	Horizontal (H)	298.5	299	299.5	mm	(1)
	Vertical (V)	194.5	195	195.5	mm	
	Depth (D)	-	(7.4)	(7.9)	mm	
Weight		-	(365)	(380)	g	

Note (1) Please refer to the attached drawings for more information of front and back outline dimensions.

2. ABSOLUTE MAXIMUM RATINGS

2.1 ABSOLUTE RATINGS OF ENVIRONMENT

Item	Symbol	Value		Unit	Note
		Min.	Max.		
Operating Ambient Temperature	T <sub>OP</sub>	-30	+70	°C	
Storage Temperature	T <sub>ST</sub>	-30	+80	°C	

Note (1) Temperature and relative humidity range is shown in the figure below.

(2) Wet-bulb temperature should be 39 °C Max. (Ta > 40 °C).

(3) No condensation.

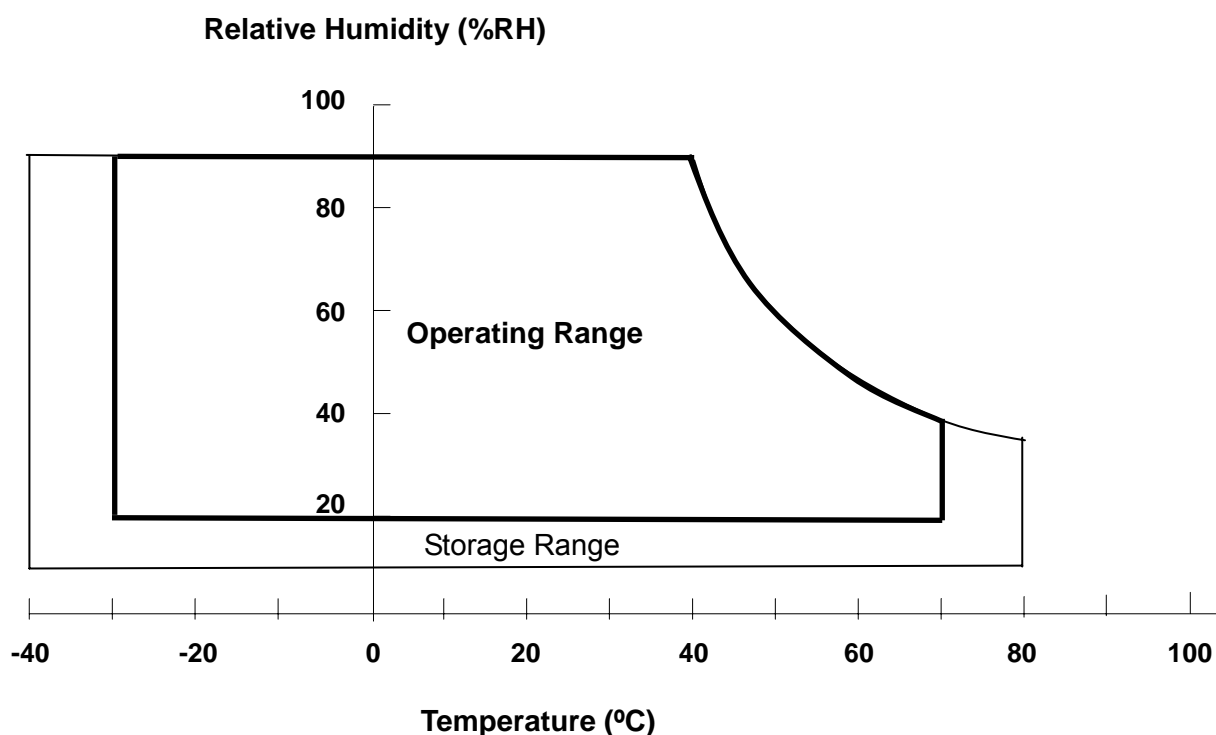



## 2.2 ELECTRICAL ABSOLUTE RATINGS

### 2.2.1 TFT LCD MODULE

Ta = 25 ± 2 °C

Item	Symbol	Value		Unit	Note
		Min.	Max.		
Power Supply Voltage	Vcc	(-0.3)	(4)	V	(1)

### 2.2.2 LED CONVERTER

Item	Symbol	Value		Unit	Note
		Min.	Max.		
Converter Voltage	V <sub>i</sub>	(4.5)	(24)	V	(1), (2)
Enable Voltage	EN	---	(5.5)	V	
Backlight Adjust	ADJ	---	(5.5)	V	

Note (1) Permanent damage to the device may occur if maximum values are exceeded. Function operation should be restricted to the conditions described under Normal Operating Conditions.

Note (2) Specified values are for LED converter (Refer to 3.2 for further information).

3. ELECTRICAL CHARACTERISTICS

3.1 RECOMMENDED OPERATION CONDITION

Ta = 25 ± 2 °C

Parameter	Symbol	Value			Unit	Note
		Min.	Typ.	Max.		
Power Supply Voltage	V <sub>CC</sub>	(3.0)	(3.3)	(3.6)	V	-
Permissible Ripple Voltage	V <sub>RP</sub>		(50)		mV	-
Rush Current	I <sub>RUSH</sub>			(1.5)	A	(2)
Initial Stage Current	I <sub>IS</sub>			(1.0)	A	(2)
Power Supply Current	White		(330)	(370)	mA	(3)a
	Black		(450)	(490)	mA	(3)b
LVDS Differential Input High Threshold	V <sub>TH(LVDS)</sub>			(+100)	mV	(4), V <sub>CM</sub> =1.2V
LVDS Differential Input Low Threshold	V <sub>TL(LVDS)</sub>	(-100)			mV	(4) V <sub>CM</sub> =1.2V
LVDS Common Mode Voltage	V <sub>CM</sub>	(0.7)		(2.0)	V	(4)
LVDS Differential Input Voltage	V <sub>ID</sub>	(100)		(600)	mV	(4)
Terminating Resistor	R <sub>T</sub>		(100)		Ohm	

Note (1) The assembly should be always operated within above ranges.

Note (2) Measurement Conditions:

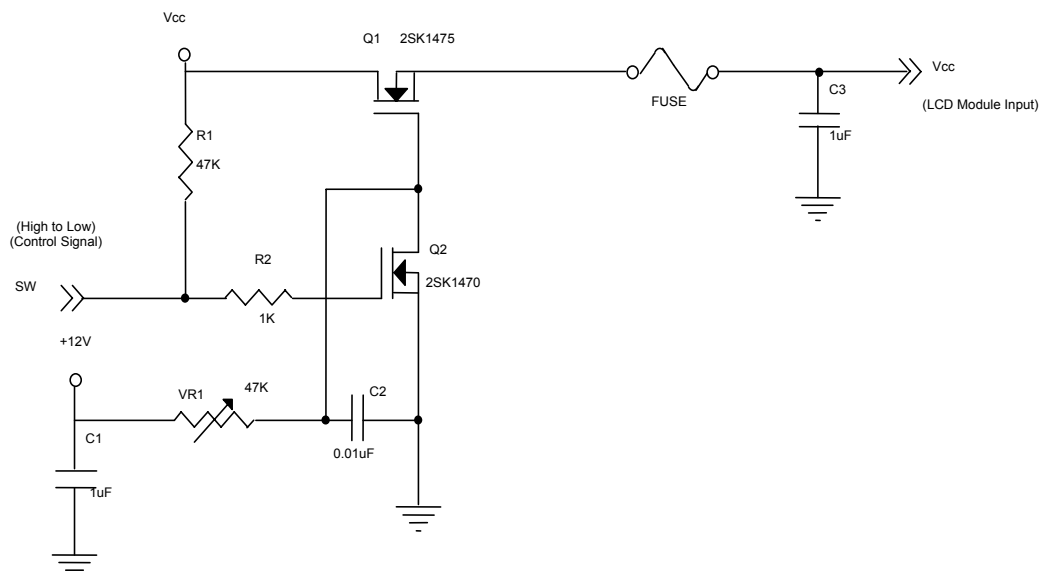

**Vcc rising time is 470μs**

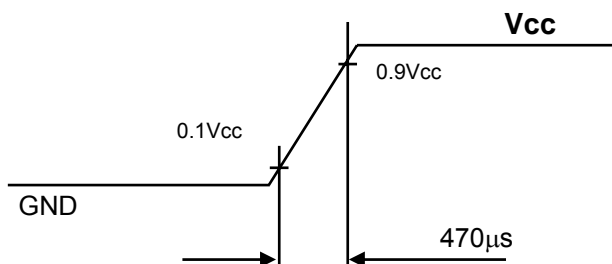

Note (3) The specified power supply current is under the conditions at  $V_{CC} = 3.3V$ ,  $T_a = 25 \pm 2^\circ C$ ,  $f_v = 60$  Hz, whereas a power dissipation check pattern below is displayed.

a. White Pattern



Active Area

b. Black Pattern



Active Area

Note (4) The parameters of LVDS signals are defined as the following figures.

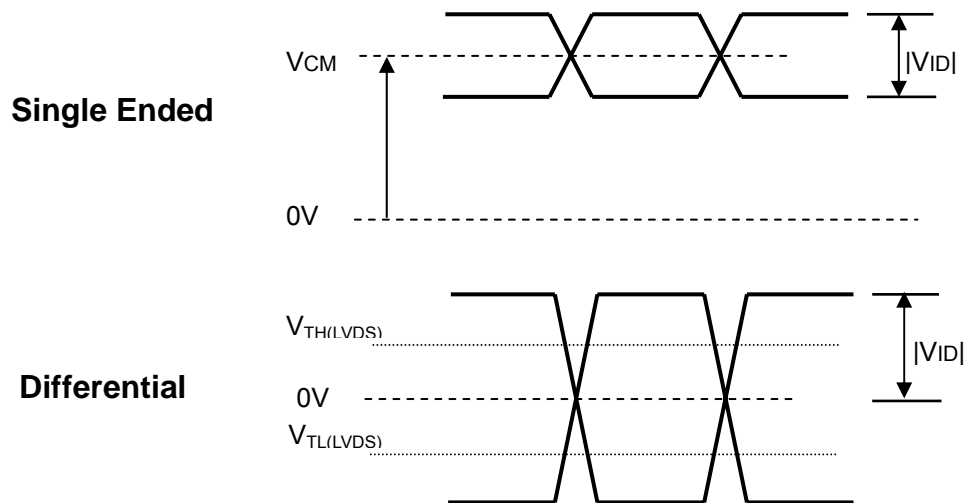

3.2 BACKLIGHT UNIT

Ta = 25 ± 2 °C

Parameter	Symbol	Value			Unit	Note
		Min.	Typ.	Max.		
Converter Power Supply Voltage	V <sub>i</sub>	(10.8)	(12.0)	(13.2)	V	
Converter Power Supply Current	I <sub>i</sub>	---	(0.43)	---	A	@ Vi = 12V (Duty 100%)
Converter Power Consumption	P <sub>LED</sub>	---	(5.16)	---	W	@ Vi = 12V (Duty 100%)
EN Control Level	Backlight on	(1.6)	---	(5)	V	
	Backlight off	(0)	---	(1)	V	
PWM Control Level	PWM High Level	(1.3)	---	(5)	V	
	PWM Low Level	(0)	---	(0.65)	V	
PWM Control Duty Ratio		(10)		(100)	%	
PWM Control Frequency	f <sub>PWM</sub>	(100)	(200)	(10K)	Hz	
LED Life Time	L <sub>L</sub>	(30,000)			Hrs	(2)

Note (1) LED current is measured by utilizing a high frequency current meter as shown below:

Note (2) The lifetime of LED is defined as the time when it continues to operate under the conditions at Ta = 25 ± 2 and I<sub>LED</sub> = 20mA<sub>DC</sub>(LED forward current) until the brightness becomes 50% of its original value.

Note (3) Please note that LED life will be shorter than the average life described in the specification if operate in higher ambient temperature.

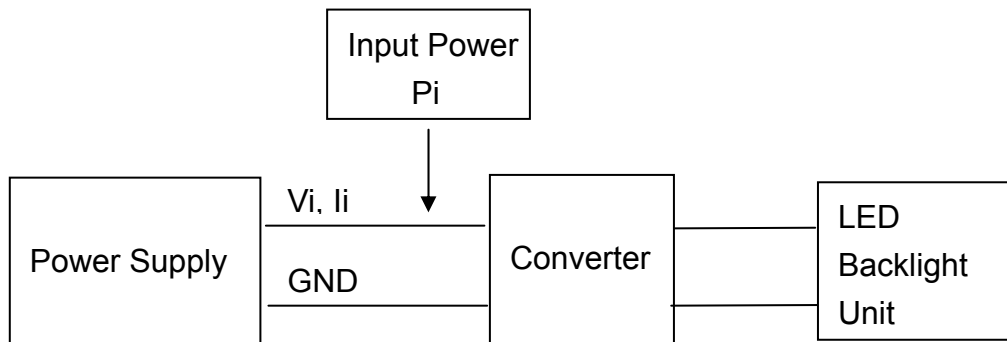

4. BLOCK DIAGRAM

4.1 TFT LCD MODULE

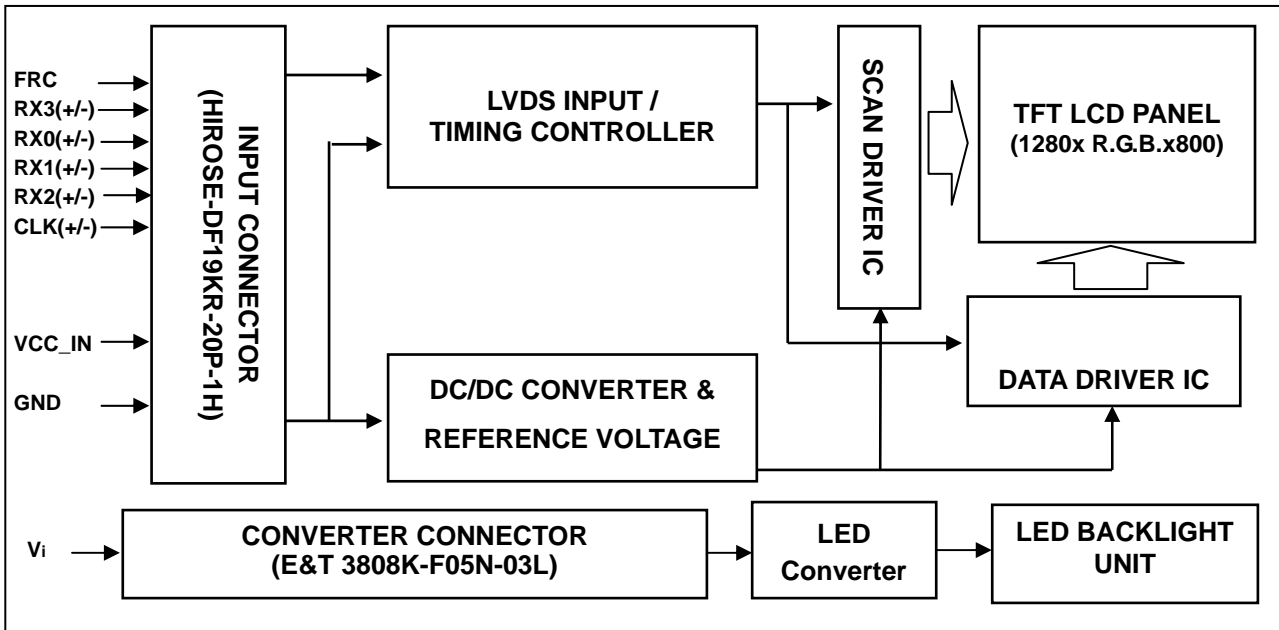

## 5. INPUT TERMINAL PIN ASSIGNMENT

### 5.1 LVDS I/O PIN ASSIGNMENT

Pin	Symbol	Description	Polarity	Remark
1	Vss	Ground		
2	Vcc	Power Supply +3.3 V (typical)		
3	Vcc	Power Supply +3.3 V (typical)		
4	NC	Non-Connection		
5	FRC	Dithering control setting When FRC=H, the width of data input 8 bits When FRC=L, the width of data input 6 bits and set Dx0 and Dx1 to logical low (Default is L)		H is 3.3V L is GND
6	Rxin3-	LVDS Differential Data Input	Negative	
7	Rxin3+	LVDS Differential Data Input	Positive	
8	Rxin0-	LVDS Differential Data Input	Negative	
9	Rxin0+	LVDS Differential Data Input	Positive	
10	Vss	Ground		
11	Rxin1-	LVDS Differential Data Input	Negative	
12	Rxin1+	LVDS Differential Data Input	Positive	
13	Vss	Ground		
14	Rxin2-	LVDS Differential Data Input	Negative	
15	Rxin2+	LVDS Differential Data Input	Positive	
16	Vss	Ground		
17	CLK-	LVDS Clock Data Input	Negative	LVDS Level Clock
18	CLK+	LVDS Clock Data Input	Positive	
19	Vss	Ground		
20	Vss	Ground		

Note (1) User's connector Part No.: DF19G-20S-1SD (HIROSE) or equivalent DF19G-20S-1For DF19G-20S-1C

### 5.2 BACKLIGHT PIN ASSIGNMENT (Converter connector pin)

Pin	Symbol	Description	Remark
1	Vi	Converter input voltage	12V
2	VGND	Converter ground	Ground
3	EN	Enable pin	3.3V
4	ADJ	Backlight Adjust	PWM Dimming (Hi: 3.3VDC, Lo: 0VDC)
5	NC	Not Connect	Ground

Note (1) User's connector Part No: E&T H208K-P05N-02B or equivalent

5.3 TIMING DIAGRAM OF LVDS INPUT SIGNAL

**FRC = "Low" or "NC" for 6 bits LVDS Input**

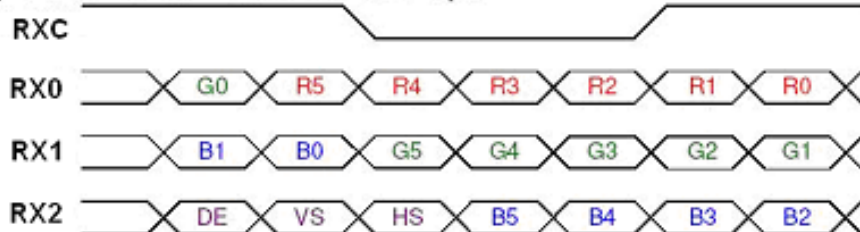

**FRC = "High" for 8 bits LVDS Input**

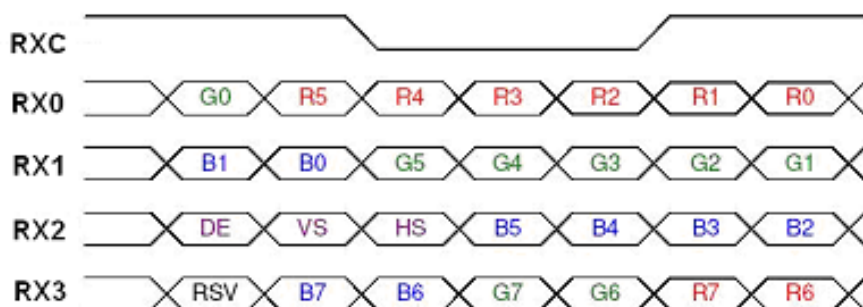

**5.4 COLOR DATA INPUT ASSIGNMENT**

The brightness of each primary color (red, green and blue) is based on the 6-bit gray scale data input for the color. The higher the binary input, the brighter the color. The table below provides the assignment of color versus data input. ( 0: Low Level Voltage, 1: High Level Voltage)

Color		Data Signal																	
		Red						Green						Blue					
		R5	R4	R3	R2	R1	R0	G5	G4	G3	G2	G1	G0	B5	B4	B3	B2	B1	B0
Basic Colors	Black	0	0	0	0	0	0	0	0	0	0	0	0	0	0	0	0	0	0
	Red	1	1	1	1	1	1	0	0	0	0	0	0	0	0	0	0	0	0
	Green	0	0	0	0	0	0	1	1	1	1	1	1	0	0	0	0	0	0
	Blue	0	0	0	0	0	0	0	0	0	0	0	0	1	1	1	1	1	1
	Cyan	0	0	0	0	0	0	1	1	1	1	1	1	1	1	1	1	1	1
	Magenta	1	1	1	1	1	1	0	0	0	0	0	0	1	1	1	1	1	1
	Yellow	1	1	1	1	1	1	1	1	1	1	1	1	0	0	0	0	0	0
	White	1	1	1	1	1	1	1	1	1	1	1	1	1	1	1	1	1	1
Gray Scale Of Red	Red(0) / Dark	0	0	0	0	0	0	0	0	0	0	0	0	0	0	0	0	0	0
	Red(1)	0	0	0	0	0	1	0	0	0	0	0	0	0	0	0	0	0	0
	Red(2)	0	0	0	0	1	0	0	0	0	0	0	0	0	0	0	0	0	0
	⋮	⋮	⋮	⋮	⋮	⋮	⋮	⋮	⋮	⋮	⋮	⋮	⋮	⋮	⋮	⋮	⋮	⋮	⋮
	⋮	⋮	⋮	⋮	⋮	⋮	⋮	⋮	⋮	⋮	⋮	⋮	⋮	⋮	⋮	⋮	⋮	⋮	⋮
	Red(61)	1	1	1	1	0	1	0	0	0	0	0	0	0	0	0	0	0	0
	Red(62)	1	1	1	1	1	0	0	0	0	0	0	0	0	0	0	0	0	0
	Red(63)	1	1	1	1	1	1	0	0	0	0	0	0	0	0	0	0	0	0
Gray Scale Of Green	Green(0) / Dark	0	0	0	0	0	0	0	0	0	0	0	0	0	0	0	0	0	0
	Green(1)	0	0	0	0	0	0	0	0	0	0	0	1	0	0	0	0	0	0
	Green(2)	0	0	0	0	0	0	0	0	0	0	1	0	0	0	0	0	0	0
	⋮	⋮	⋮	⋮	⋮	⋮	⋮	⋮	⋮	⋮	⋮	⋮	⋮	⋮	⋮	⋮	⋮	⋮	⋮
	⋮	⋮	⋮	⋮	⋮	⋮	⋮	⋮	⋮	⋮	⋮	⋮	⋮	⋮	⋮	⋮	⋮	⋮	⋮
	Green(61)	0	0	0	0	0	0	1	1	1	1	0	1	0	0	0	0	0	0
	Green(62)	0	0	0	0	0	0	1	1	1	1	1	0	0	0	0	0	0	0
	Green(63)	0	0	0	0	0	0	1	1	1	1	1	1	0	0	0	0	0	0
Gray Scale Of Blue	Blue(0) / Dark	0	0	0	0	0	0	0	0	0	0	0	0	0	0	0	0	0	0
	Blue(1)	0	0	0	0	0	0	0	0	0	0	0	0	0	0	0	0	0	1
	Blue(2)	0	0	0	0	0	0	0	0	0	0	0	0	0	0	0	0	1	0
	⋮	⋮	⋮	⋮	⋮	⋮	⋮	⋮	⋮	⋮	⋮	⋮	⋮	⋮	⋮	⋮	⋮	⋮	⋮
	⋮	⋮	⋮	⋮	⋮	⋮	⋮	⋮	⋮	⋮	⋮	⋮	⋮	⋮	⋮	⋮	⋮	⋮	⋮
	Blue(61)	0	0	0	0	0	0	0	0	0	0	0	0	1	1	1	1	0	1
	Blue(62)	0	0	0	0	0	0	0	0	0	0	0	0	1	1	1	1	1	0
	Blue(63)	0	0	0	0	0	0	0	0	0	0	0	0	1	1	1	1	1	1



The brightness of each primary color (red, green and blue) is based on the 8-bit gray scale data input for the color. The higher the binary input, the brighter the color. The table below provides the assignment of color versus data input.

( 0: Low Level Voltage, 1: High Level Voltage)

Color		Data Signal																						
		Red								Green								Blue						
		R7	R6	R5	R4	R3	R2	R1	R0	G7	G6	G5	G4	G3	G2	G1	G0	B7	B6	B5	B4	B3	B2	B1
Basic Colors	Black	0	0	0	0	0	0	0	0	0	0	0	0	0	0	0	0	0	0	0	0	0	0	0
	Red	1	1	1	1	1	1	1	1	0	0	0	0	0	0	0	0	0	0	0	0	0	0	0
	Green	0	0	0	0	0	0	0	0	1	1	1	1	1	1	1	1	0	0	0	0	0	0	0
	Blue	0	0	0	0	0	0	0	0	0	0	0	0	0	0	0	0	1	1	1	1	1	1	1
	Cyan	0	0	0	0	0	0	0	0	1	1	1	1	1	1	1	1	1	1	1	1	1	1	1
	Magenta	1	1	1	1	1	1	1	1	0	0	0	0	0	0	0	0	1	1	1	1	1	1	1
	Yellow	1	1	1	1	1	1	1	1	1	1	1	1	1	1	1	1	0	0	0	0	0	0	0
	White	1	1	1	1	1	1	1	1	1	1	1	1	1	1	1	1	1	1	1	1	1	1	1
Gray Scale Of Red	Red(0) / Dark	0	0	0	0	0	0	0	0	0	0	0	0	0	0	0	0	0	0	0	0	0	0	
	Red(1)	0	0	0	0	0	0	0	1	0	0	0	0	0	0	0	0	0	0	0	0	0	0	
	Red(2)	0	0	0	0	0	0	1	0	0	0	0	0	0	0	0	0	0	0	0	0	0	0	
	:	:	:	:	:	:	:	:	:	:	:	:	:	:	:	:	:	:	:	:	:	:	:	
	:	:	:	:	:	:	:	:	:	:	:	:	:	:	:	:	:	:	:	:	:	:	:	
	Red(253)	1	1	1	1	1	1	0	1	0	0	0	0	0	0	0	0	0	0	0	0	0	0	
	Red(254)	1	1	1	1	1	1	1	0	0	0	0	0	0	0	0	0	0	0	0	0	0	0	
	Red(255)	1	1	1	1	1	1	1	1	0	0	0	0	0	0	0	0	0	0	0	0	0	0	
Gray Scale Of Green	Green(0)/ Dark	0	0	0	0	0	0	0	0	0	0	0	0	0	0	0	0	0	0	0	0	0	0	
	Green(1)	0	0	0	0	0	0	0	0	0	0	0	0	0	0	0	1	0	0	0	0	0	0	
	Green(2)	0	0	0	0	0	0	0	0	0	0	0	0	0	0	1	0	0	0	0	0	0	0	
	:	:	:	:	:	:	:	:	:	:	:	:	:	:	:	:	:	:	:	:	:	:	:	
	:	:	:	:	:	:	:	:	:	:	:	:	:	:	:	:	:	:	:	:	:	:	:	
	Green(253)	0	0	0	0	0	0	0	0	1	1	1	1	1	1	0	1	0	0	0	0	0	0	
	Green(254)	0	0	0	0	0	0	0	0	1	1	1	1	1	1	1	0	0	0	0	0	0	0	
	Green(255)	0	0	0	0	0	0	0	0	1	1	1	1	1	1	1	1	0	0	0	0	0	0	
Gray Scale Of Blue	Blue(0) / Dark	0	0	0	0	0	0	0	0	0	0	0	0	0	0	0	0	0	0	0	0	0	0	
	Blue(1)	0	0	0	0	0	0	0	0	0	0	0	0	0	0	0	0	0	0	0	0	0	1	
	Blue(2)	0	0	0	0	0	0	0	0	0	0	0	0	0	0	0	0	0	0	0	0	0	1	
	:	:	:	:	:	:	:	:	:	:	:	:	:	:	:	:	:	:	:	:	:	:	:	
	:	:	:	:	:	:	:	:	:	:	:	:	:	:	:	:	:	:	:	:	:	:	:	
	Blue(253)	0	0	0	0	0	0	0	0	0	0	0	0	0	0	0	1	1	1	1	1	1	0	
	Blue(254)	0	0	0	0	0	0	0	0	0	0	0	0	0	0	0	1	1	1	1	1	1	1	
	Blue(255)	0	0	0	0	0	0	0	0	0	0	0	0	0	0	0	1	1	1	1	1	1	1	

6. INTERFACE TIMING

6.1 TIMING CHARACTERISTICS

The specifications of input signal timing are as the following table and timing diagram.

Signal	Item	Symbol	Min.	Typ.	Max.	Unit	Note
DCLK	Frequency	1/Tc	(50)	(71)	(80)	MHz	-
DE	Vertical Total Time	TV	(810)	(823)	(1023)	TH	-
	Vertical Addressing Time	TVD	(800)	(800)	(800)	TH	-
	Horizontal Total Time	TH	(1360)	(1440)	(1800)	Tc	-
	Horizontal Addressing Time	THD	(1280)	(1280)	(1280)	Tc	-

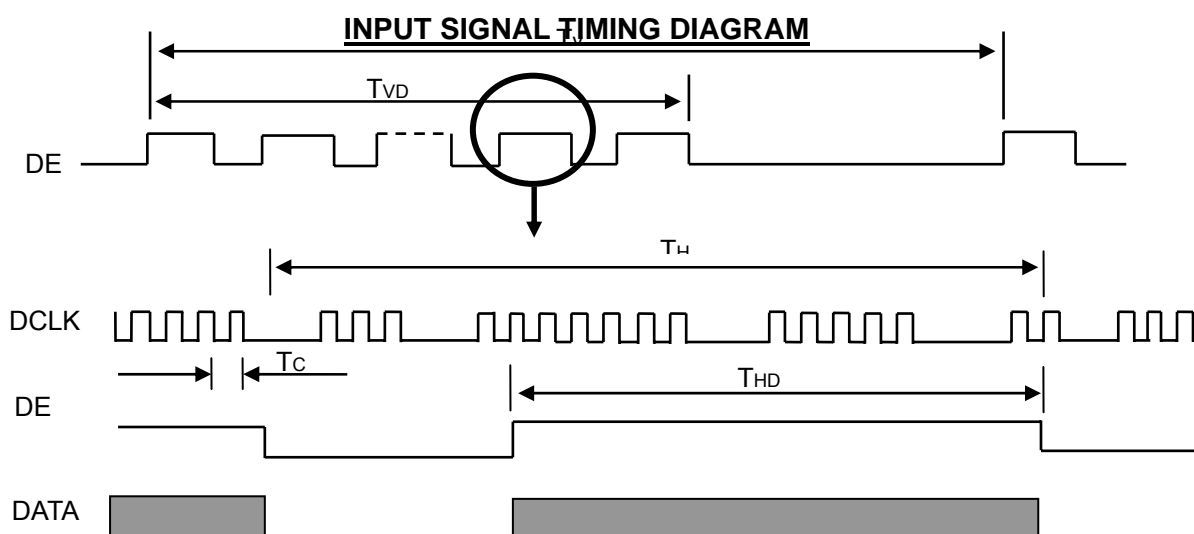

## 6.2 POWER ON/OFF SEQUENCE

To prevent a latch-up or DC operation of LCD assembly, the power on/off sequence should be as the diagram below

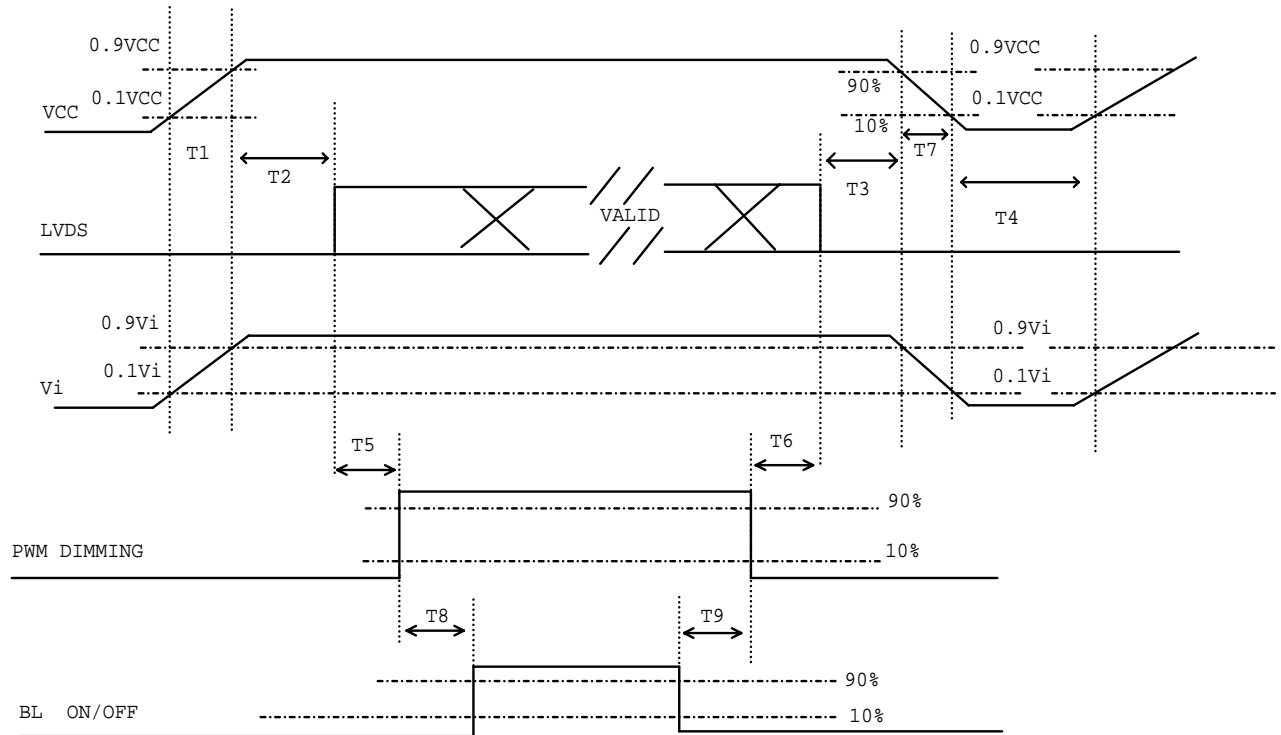

### Power ON/OFF sequence

Note (1) Please avoid floating state of interface signal at invalid period.

Note (2) When the interface signal is invalid, be sure to pull down the power supply of LCD VCC to 0 V.

Note (3) The Backlight converter power must be turned on after the power supply for the logic and the interface signal is valid. The Backlight converter power must be turned off before the power supply for the logic and the interface signal is invalid.

Parameter	Value			Units
	Min	Typ	Max	
T1	(0.5)	-	(10)	ms
T2	(0)	-	(50)	ms
T3	(0)	-	(50)	ms
T4	(500)	-	-	ms
T5	(20)	-	-	ms
T6	(10)	-	-	ms
T7	(5)	-	(300)	ms
T8	(10)	-	-	ms
T9	(10)	-	-	ms

7. OPTICAL CHARACTERISTICS

7.1 TEST CONDITIONS

Item	Symbol	Value	Unit
Ambient Temperature	Ta	25±2	°C
Ambient Humidity	Ha	50±10	%RH
Supply Voltage	V <sub>CC</sub>	3.3	V
Input Signal	According to typical value in "3. ELECTRICAL CHARACTERISTICS"		
Current	I <sub>f</sub>	20±3	mA
Converter Duty		100	%

Note (1) I<sub>f</sub> means the forward current of each channel

7.2 OPTICAL SPECIFICATIONS

The relative measurement methods of optical characteristics are shown in 7.2. The following items should be measured under the test conditions described in 7.1 and stable environment shown in Note (6).

Item		Symbol	Condition	Min.	Typ.	Max.	Unit	Note
Color Chromaticity	Red	R <sub>x</sub>	$\theta_x=0^\circ, \theta_y=0^\circ$ Viewing Normal Angle	Typ - 0.05	(0.606)	Typ + 0.05		(1), (6)
		R <sub>y</sub>			(0.342)			
	Green	G <sub>x</sub>			(0.338)			
		G <sub>y</sub>			(0.541)			
	Blue	B <sub>x</sub>			(0.158)			
		B <sub>y</sub>			(0.144)			
	White	W <sub>x</sub>			(0.313)			
		W <sub>y</sub>			(0.329)			
Center Luminance of White		L <sub>C</sub>		(400)	(500)		cd/m <sup>2</sup>	(4), (6)
Contrast Ratio		CR		(550)	(800)		-	(2), (6)
Response Time		T <sub>R</sub>			(6)	(11)	Ms	(3)
		T <sub>F</sub>			(10)	(15)	Ms	
White Variation		δW			(1.25)	(1.4)	-	(5), (6)
Viewing Angle	Horizontal	θ <sub>x+</sub>	CR 10		(60)	(70)		Deg.
		θ <sub>x-</sub>			(60)	(70)		
	Vertical	θ <sub>y+</sub>			(50)	(60)		
		θ <sub>y-</sub>			(50)	(60)		

Note (1) Definition of Viewing Angle ( $\theta_x$ ,  $\theta_y$ ):

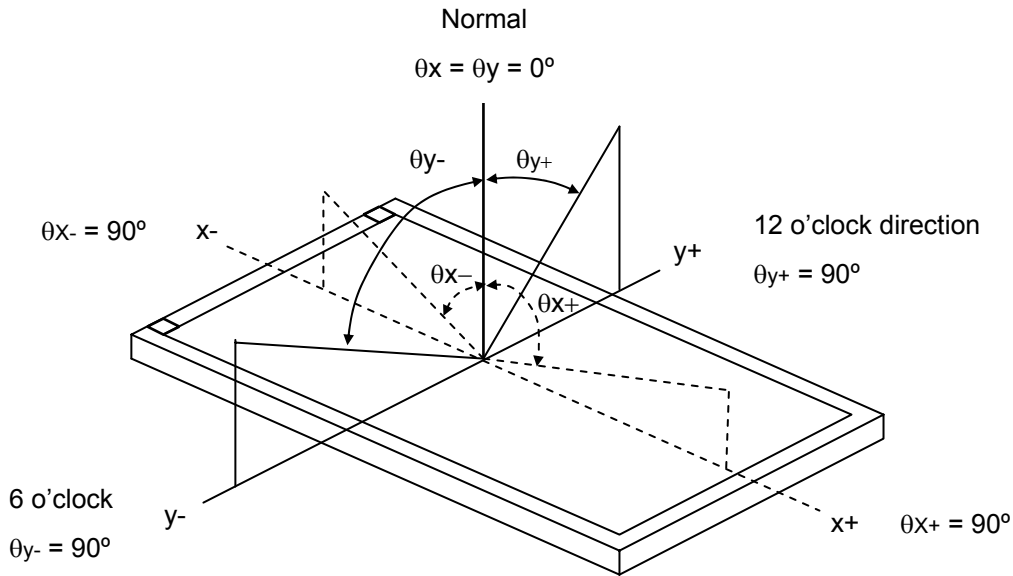

Note (2) Definition of Contrast Ratio (CR):

The contrast ratio can be calculated by the following expression.

$$\text{Contrast Ratio (CR)} = L_{63} / L_0$$

L63: Luminance of gray level 63

L 0: Luminance of gray level 0

$$CR = CR(5)$$

CR (X) is corresponding to the Contrast Ratio of the point X at Figure in Note (5).

Note (3) Definition of Response Time ( $T_R$ ,  $T_F$ ) and measurement method:

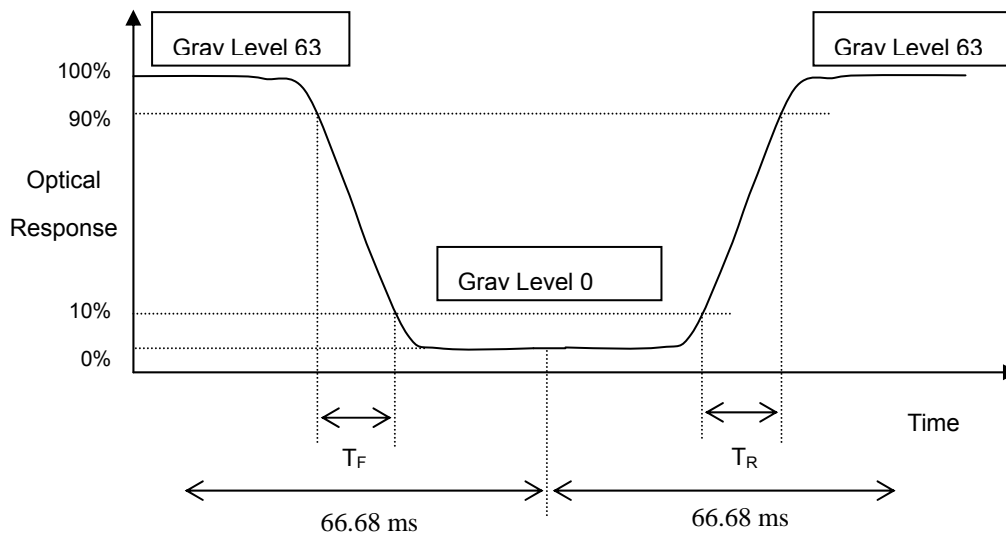

Note (4) Definition of Luminance of White ( $L_C$ ):

Measure the luminance of gray level 63 at center point

$$L_C = L(5)$$

$L(x)$  is corresponding to the luminance of the point X at Figure in Note (5).

Note (5) Definition of White Variation ( $\delta W$ ):

Measure the luminance of gray level 63 at 5 points

$$\delta W = \text{Maximum} [L(1), L(2), L(3), L(4), L(5)] / \text{Minimum} [L(1), L(2), L(3), L(4), L(5)]$$

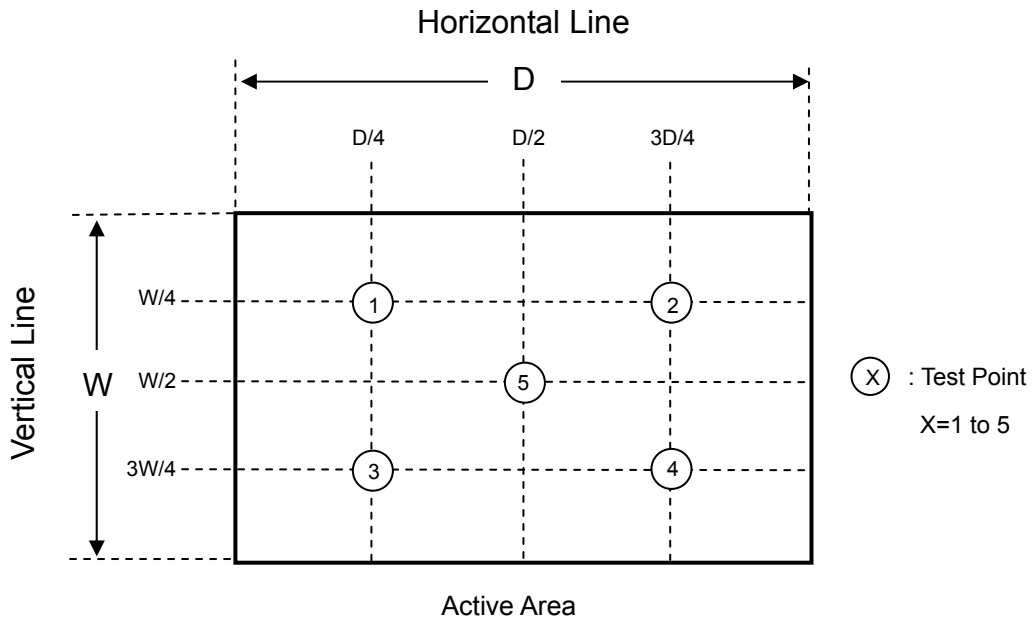

Note (6) Measurement Setup:

The LCD module should be stabilized at given temperature for 20 minutes to avoid abrupt temperature change during measuring. In order to stabilize the luminance, the measurement should be executed after lighting Backlight for 20 minutes in a windless room.

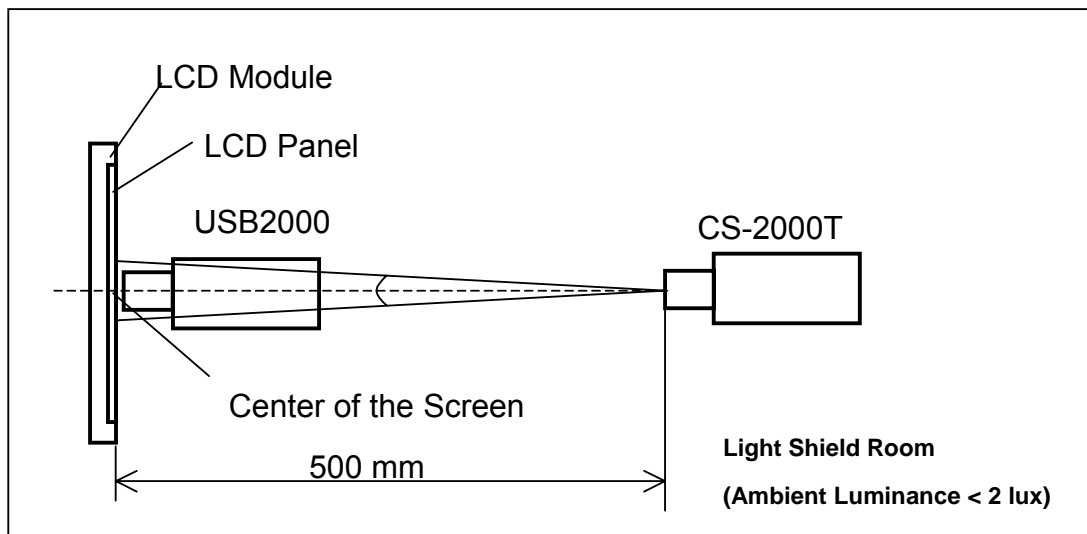

8. RELIABILITY TEST

8.1 RELIABILITY TEST CONDITION

No.	Test Item	Test Condition	Note
1	High Temperature Storage	80 , 240 hours	(1) (2)
2	Low Temperature Storage	-30 , 240 hours	
3	Thermal Shock Storage	{{(-30 , 0.5 hour) (80 , 0.5 hour)}, 100 cycles	
4	High Temperature Operating	70 , 240 hours	
5	Low Temperature Operating	-30 , 240 hours	
6	High Temperature & High Humidity Operating	60 , 90% RH, 240hours	
7	Shock (Non-Operating)	200G, 2ms, half sine wave, 1 time for ± X, ± Y, ± Z.	(3)
8	Vibration (Non-Operating)	1.5G, 10~300Hz, 10min/cycle, 3 cycles each X,Y,Z	(3)

Note (1) There should be no condensation on the surface of panel during test.

Note (2) The temperature of panel display surface area should be 80 Max.

Note (3) At testing Vibration and Shock, the fixture in holding the module has to be hard and rigid enough so that the module would not be twisted or bent by the fixture.

Note (4) In the standard conditions, there is no function failure issue occurred. All the cosmetic specification is judged before the reliability test.

9. PACKAGING

9.1 PACKING SPECIFICATIONS

- (1) 20pcs LCD modules / 1 Box
- (2) Box dimensions: 520(L)x310(W)x415(H)mm
- (3) Weight: approximately 13 Kg (20modules per box)

9.2 PACKING METHOD

- (1) Carton Packing should have no failure in the following reliability test items.

Test Item	Test Conditions	Note
Vibration	ISTA STANDARD Random, Frequency Range: 2 – 200 Hz Top & Bottom: 30 minutes (+Z), 10 min (-Z), Right & Left: 10 minutes (X) Back & Forth 10 minutes (Y)	Non Operation
Dropping Test	1 Angle, 3 Edge, 6 Face, 61 cm	Non Operation

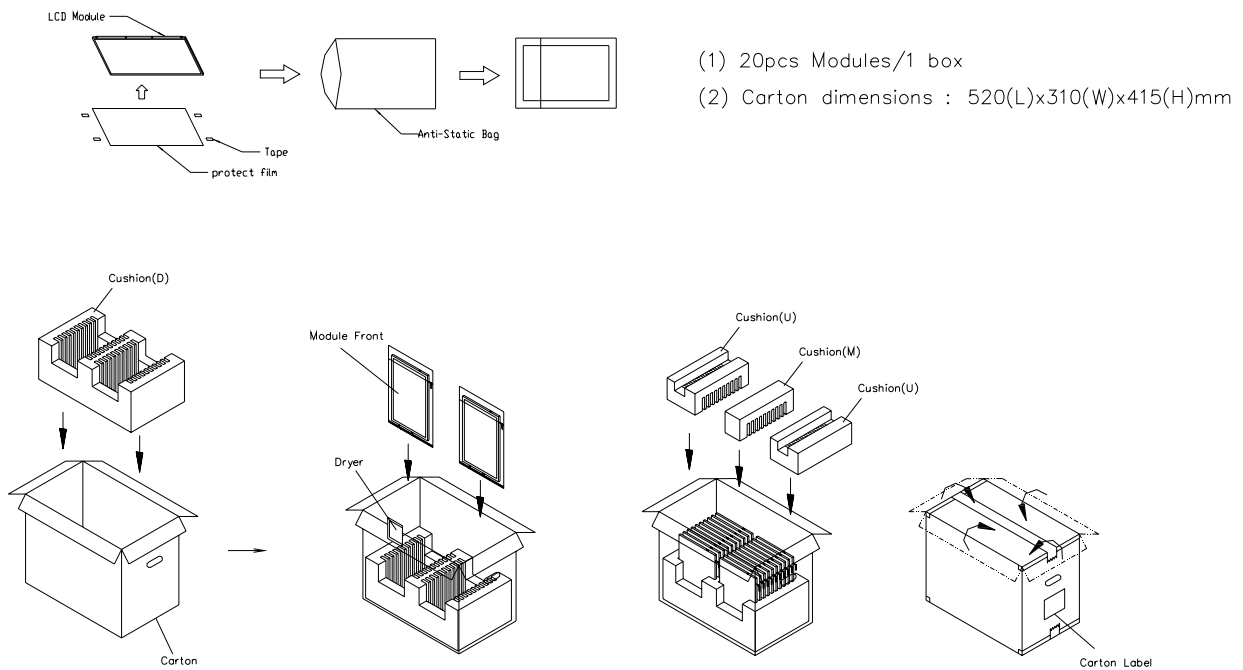

Figure. 9-1 Packing method



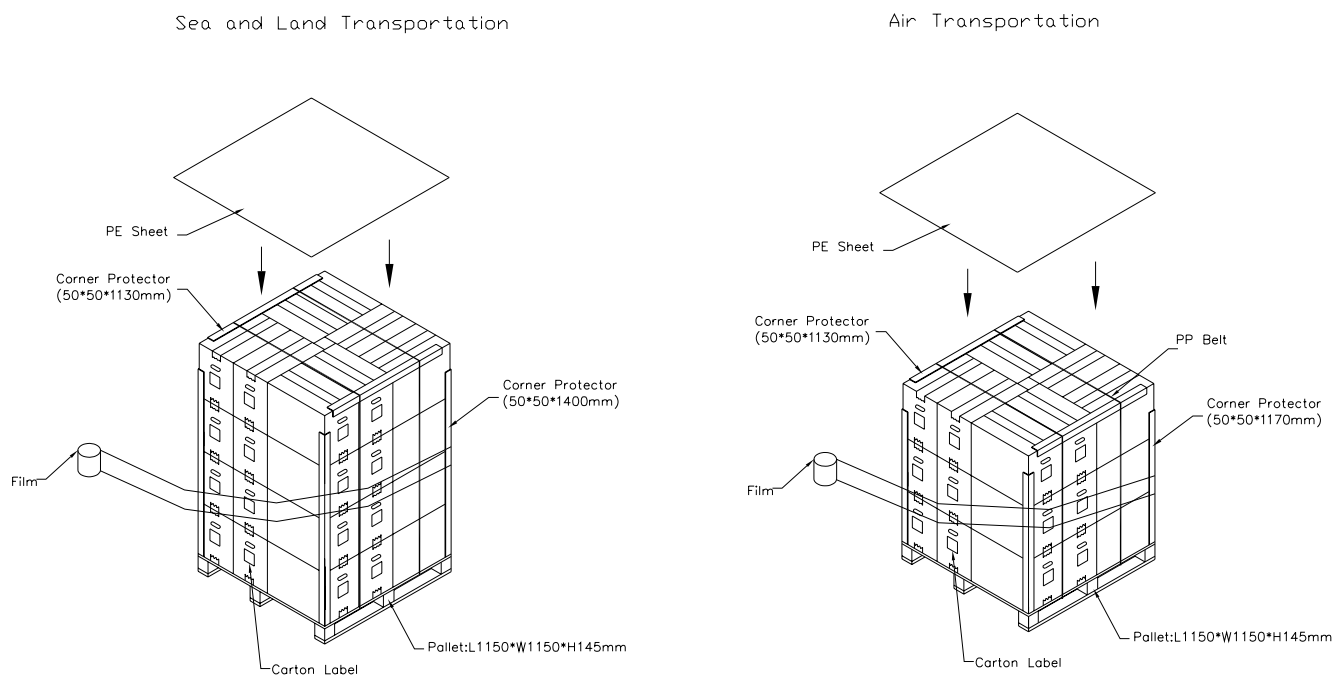

Figure. 9-2 Packing method

10. DEFINITION OF LABEL

10.1 CMI MODULE LABEL

The barcode nameplate is pasted on each module as illustration, and its definitions are as following explanation.



- (a) Model Name: G133IGE -L03
- (b) Revision: Rev. XX, for example: A1, ..., C1, C2 ...etc.
- (c) Serial ID: XXXXXXXXYMDXNNNN

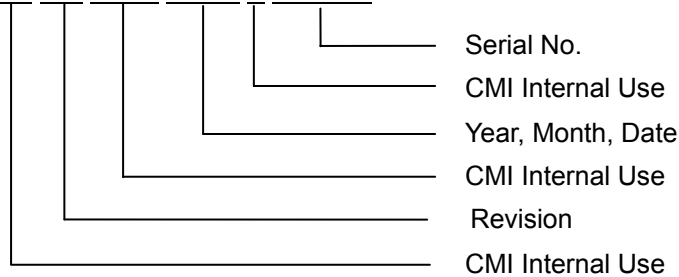

Serial ID includes the information as below:

- (a) Manufactured Date: Year: 1~9, for 2001~2009  
 Month: 1~9, A~C, for Jan. ~ Dec.  
 Day: 1~9, A~Y, for 1<sup>st</sup> to 31<sup>st</sup>, exclude I, O and U
- (b) Revision Code: cover all the change  
 Serial No.: Manufacturing sequence of product

## 11. PRECAUTIONS

### 11.1 ASSEMBLY AND HANDLING PRECAUTIONS

- (1) Do not apply rough force such as bending or twisting to the module during assembly.
- (2) To assemble or install module into user's system can be only in clean working areas. The dust and oil may cause electrical short or worsen the polarizer.
- (3) It's not permitted to have pressure or impulse on the module because the LCD panel and Backlight will be damaged.
- (4) Always follow the correct power sequence when LCD module is connecting and operating. This can prevent damage to the CMOS LSI chips during latch-up.
- (5) Do not pull the I/F connector in or out while the module is operating.
- (6) Do not disassemble the module.
- (7) Use a soft dry cloth without chemicals for cleaning, because the surface of polarizer is very soft and easily scratched.
- (8) It is dangerous that moisture come into or contacted the LCD module, because moisture may damage LCD module when it is operating.
- (9) High temperature or humidity may reduce the performance of module. Please store LCD module within the specified storage conditions.
- (10) When ambient temperature is lower than 10°C may reduce the display quality. For example, the response time will become slowly.
- (11) Do not keep same pattern in a long period of time. It may cause image sticking on LCD

### 11.2 SAFETY PRECAUTIONS

- (1) Do not disassemble the module or insert anything into the Backlight unit to prevent electrical shock.
- (2) If the liquid crystal material leaks from the panel, it should be kept away from the eyes or mouth. In case of contact with hands, skin or clothes, it has to be washed away thoroughly with soap.
- (3) After the module's end of life, it is not harmful in case of normal operation and storage.

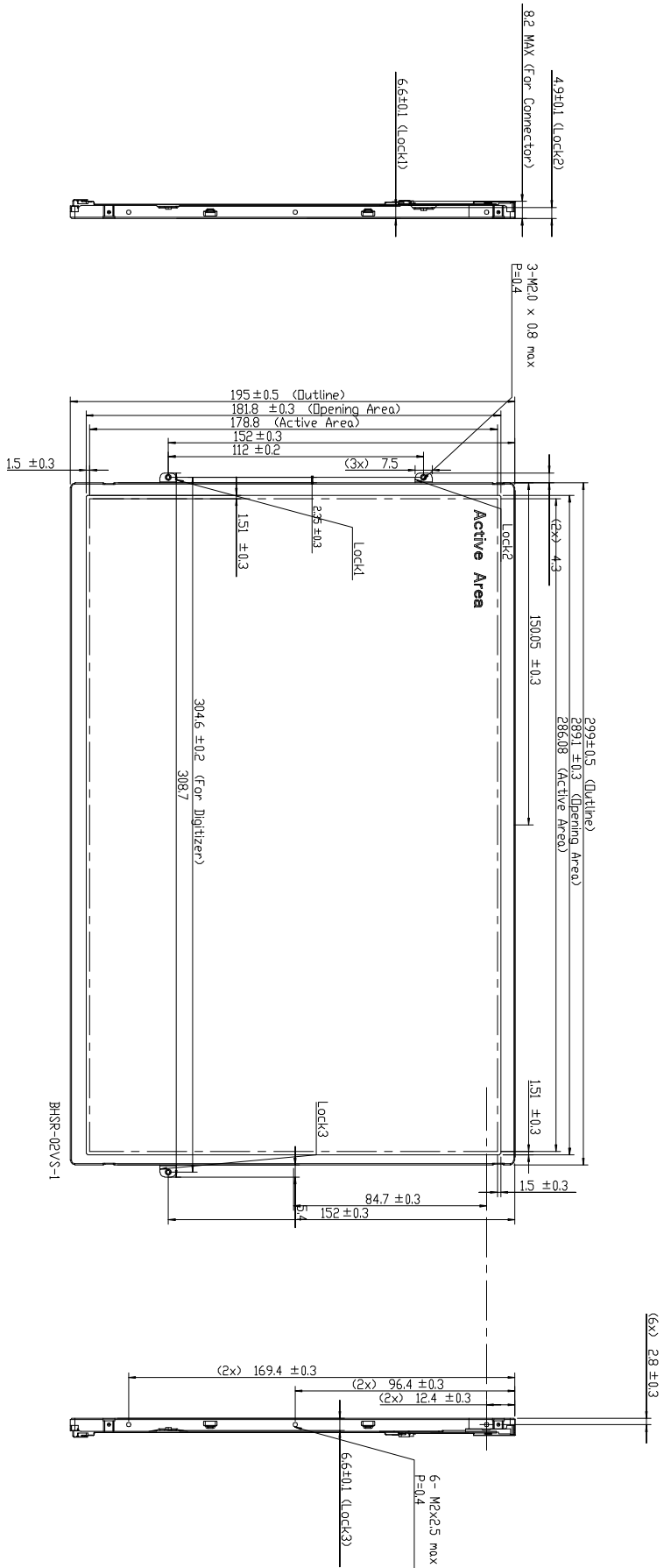

NOTES:  
 1. GENERAL TOLERANCE :  $\pm 0.5$  MM  
 2. SCREW TORQUE FOR FRONT MOUNTING SHALL NOT EXCEED  $1.5$  KGF-CM  
 3. SCREW HOLE DEPTH  $2.5$ MM MAX  
 4. MAX SCREW TORQUE :  $2$  KGF-CM

Rev	Description	Date	Checked By	Approved By	ECN No.	Remark
2						
3						
4						

General	Tolerance	Unless Specified
0-6	$\pm 0.1$	0.00-0.05
6-30	$\pm 0.15$	0.05-0.10
30-500	$\pm 0.2$	0.10-0.15

Rev	ECN
01	01
02	01

Approved	Checked	Design	Drawn	Scale	Sheet	Total
					1	1

Part No.	Rev	Date	Scale	Drawn

Part No.	Rev	Date	Scale	Drawn

Part No.	Rev	Date	Scale	Drawn

Part No.	Rev	Date	Scale	Drawn

Part No.	Rev	Date	Scale	Drawn

Part No.	Rev	Date	Scale	Drawn

Part No.	Rev	Date	Scale	Drawn

Part No.	Rev	Date	Scale	Drawn

Part No.	Rev	Date	Scale	Drawn

Part No.	Rev	Date	Scale	Drawn

Part No.	Rev	Date	Scale	Drawn

Part No.	Rev	Date	Scale	Drawn

Part No.	Rev	Date	Scale	Drawn

Part No.	Rev	Date	Scale	Drawn

Part No.	Rev	Date	Scale	Drawn

Part No.	Rev	Date	Scale	Drawn

Part No.	Rev	Date	Scale	Drawn

Part No.	Rev	Date	Scale	Drawn

Part No.	Rev	Date	Scale	Drawn

Part No.	Rev	Date	Scale	Drawn

Part No.	Rev	Date	Scale	Drawn

Part No.	Rev	Date	Scale	Drawn

Part No.	Rev	Date	Scale	Drawn

Part No.	Rev	Date	Scale	Drawn

Part No.	Rev	Date	Scale	Drawn

Part No.	Rev	Date	Scale	Drawn

Part No.	Rev	Date	Scale	Drawn

Part No.	Rev	Date	Scale	Drawn

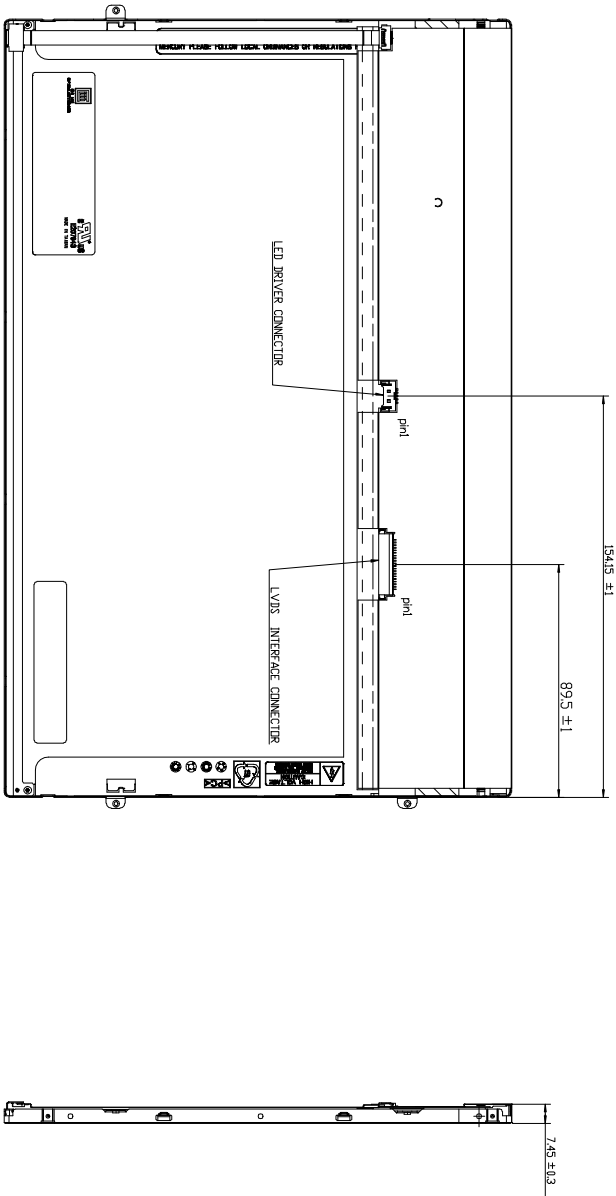

Mark	Description	Date	Changed By	Approved By	ECN No.	Remark
2						
3						
4						
5						
6						
7						
8						
9						
10						
11						
12						
13						
14						
15						
16						

General	Tolerance	Unless Specified	Standard
0-6	±0.1	300-600	±0.3
6-30	±0.15	600-	±0.6
30-500	±0.2	RANGE	±1.0

TITLE: N551 MODULE CARRIER-43		REV: 1
Checked	Drawing No.	100
Designed	Part No.	100
Approved	Material	100
Released	Date: 08-May-2008	Scale: 1:1
CHI MET		Sheet: 2 of 11
CHI ELECTRONICS CORP.		Part No.
ALL RIGHTS RESERVED. COMPANY PROPRIETARY.		

Our company network supports you worldwide with offices in Germany, Austria, Switzerland, the UK and the USA. For more information please contact:

## Headquarters

Germany



**FORTEC Elektronik AG**

Lechwiesenstr. 9  
86899 Landsberg am Lech

Phone: +49 8191 91172-0  
E-Mail: [sales@forteca.de](mailto:sales@forteca.de)  
Internet: [www.forteca.de](http://www.forteca.de)

## Fortec Group Members

Austria



**FORTEC Elektronik AG**

**Office Vienna**

Nuschinggasse 12  
1230 Wien

Phone: +43 1 8673492-0  
E-Mail: [office@fortec.at](mailto:office@fortec.at)  
Internet: [www.fortec.at](http://www.fortec.at)

Germany



**Distec GmbH**

Augsburger Str. 2b  
82110 Germering

Phone: +49 89 894363-0  
E-Mail: [info@distec.de](mailto:info@distec.de)  
Internet: [www.distec.de](http://www.distec.de)

Switzerland



**ALTRAC AG**

Bahnhofstraße 3  
5436 Würenlos

Phone: +41 44 7446111  
E-Mail: [info@altrac.ch](mailto:info@altrac.ch)  
Internet: [www.altrac.ch](http://www.altrac.ch)

United Kingdom



**Display Technology Ltd.**

Osprey House, 1 Osprey Court  
Hichingbrooke Business Park  
Huntingdon, Cambridgeshire, PE29 6FN

Phone: +44 1480 411600  
E-Mail: [info@displaytechnology.co.uk](mailto:info@displaytechnology.co.uk)  
Internet: [www.displaytechnology.co.uk](http://www.displaytechnology.co.uk)

USA



**Apollo Display Technologies, Corp.**

87 Raynor Avenue,  
Unit 1 Ronkonkoma,  
NY 11779

Phone: +1 631 5804360  
E-Mail: [info@apolloDisplays.com](mailto:info@apolloDisplays.com)  
Internet: [www.apolloDisplays.com](http://www.apolloDisplays.com)