



OUR GLOBAL
COMPETENCE
CENTRES

 APOLLO DISPLAY
TECHNOLOGIES



 DISTEC



 DISPLAY
TECHNOLOGY



Datasheet

Kyocera (Optrex)

T-55619GD065J-LW-AAN

OP-01-110

The information contained in this document has been carefully researched and is, to the best of our knowledge, accurate. However, we assume no liability for any product failures or damages, immediate or consequential, resulting from the use of the information provided herein. Our products are not intended for use in systems in which failures of product could result in personal injury. All trademarks mentioned herein are property of their respective owners. All specifications are subject to change without notice.

LCD Module Technical Specification

液晶表示モジュール仕様書

First Edition 初版作成
Jun. 20, 2011

Final Revision 最終改訂

Type No. **T-55619GD065J-LW-AAN**

Customer : **OPTREX STANDARD / オプトレックススタンダード**

Customer's Product No : -----

OPTREX CORPORATION

Approved: *Takanobu Ishiwatari*
QUALITY ASSURANCE DIVISION

Checked: *Hiroyuki Miyanishi*
Design Div.

Prepared: *Hironori Miyano*
Design Div.

APPROVED

By

Signature :

Date :

Please return this specification within two month with your signature.
If not returned within two month, specification will be considered
as having been accepted.

受領印ご押印の上、弊社担当者までご返却ください。
ご返却なき場合は、問題ないものとして取り扱い処理させていただきます。

Table of Contents (目次)

1. Application (適用)	3
2. General Specifications (一般仕様)	3
3. Operating Conditions (環境条件)	4
4. Dimensional Outline (外観図)	5
5. Block Diagram (ブロック図)	6
6. I/O Terminal (I/O端子)	7
7. Electrical Specifications (電氣的仕様)	9
8. Optical Specifications (光学仕様)	16
9. Test (試験)	21
10. Appearance Standards (外観規格)	23
11. Code System of Production Lot (製造ロット番号)	27
12. Type Number (製品型式)	27
13. Applying Precautions (運用上の注意)	27
14. Precautions Relating Product Handling (製品取扱い上の注意)	28
15. Warranty (保証条件)	31

Revision History (改訂履歴)

Rev.(改版)	Date(改訂日)	Page(ページ)	Comment (内容)

1. Application (適用)

This specification applies to TFT-LCD module (T-55619GD065J-LW-AAN).
弊社仕様書は、オプトレックス(株)が製造する TFT-LCD モジュール
(品番：T-55619GD065J-LW-AAN) に適用する。

2. General Specifications (一般仕様)

Resolution (画素数)	: 640 x 3 [R.G.B] (W) x 480 (H) dots
Dot pitch (ドットピッチ)	: 0.069 x 3 [R.G.B] (W) x 0.207 (V) mm
Pixel arrangement (画素配列)	: RGB-Stripe
Color depth (色数)	: 262,144 colors
Active Viewing Area (有効視野範囲)	: 132.5 (W) x 99.4 (H) mm
Outline dimensions * (外形寸法)	: 158.0 (W) x 120.36 (H) x 10.5 (D) mm * Excluding backlight cables.(バックライトケーブルを含まない)
Weight (重量)	: 230g max.
LCD type (LCD タイプ)	: ATS-22174 TFT / Normally white-mode / Transmissive (TFT / ノーマリーホワイト / 透過型)
Viewing angle (視角)	: 6:00
Surface Treatment (表面処理)	: AG Coating
Interface (データ転送方式)	: LVDS (Low Voltage Differential Signaling) (小振幅差動信号方式)
Backlight (照明仕様)	: LED Backlight / White (LED バックライト / 白色)
Lead free (鉛フリー)	: Our product corresponds to lead free. Lead free is defined as below: 1) The solder used in the LCD module. 2) Electrical components (Terminal section) used in the LCD module. Any lead used within the electrical component does not apply to our module definition of lead free. 本製品は、鉛フリーに対応しております。 当社の鉛フリーの定義は以下の通りです。 (1) 液晶モジュールに使用している「半田」 (2) 液晶モジュールに使用している「電子部品 (端子部分)」 但し、電子部品内部に含まれている鉛は対象外とします。

RoHS regulation (RoHS 規定) : To our best knowledge, this product satisfies material requirement of RoHS regulation.
 Our company is doing the best efforts to obtain the equivalent certificate from our suppliers.
 : 当社の認知する限りにおいて、本製品は RoHS 規定の主要要件を満たしていると認識しております。
 当社としては、部材メーカー等に対して同様の保証を求めべく最大限の努力を行っております。

3. Operating Conditions (環境条件)

Item (項目)	Conditions (条件)	Temperature Range (温度範囲)	Remark (備考)
Operating Temperature Range (動作温度範囲)	PNL Surface (パネル表面)	-20~70°C	Note1 (注 1)
Storage Temperature Range (保存温度範囲)	PNL Surface (パネル表面)	-20~70°C	

Note1: Operating temperature range defines the operation only and the contrast, response time and other display optical characteristics are set at Ta=+25°C.

注 1 : 動作温度範囲は、動作のみを保証する温度であり、コントラスト、応答速度、その他の表示品位、光学性能は Ta=+25°Cにて判定します。

4. Dimensional Outline (外觀図)

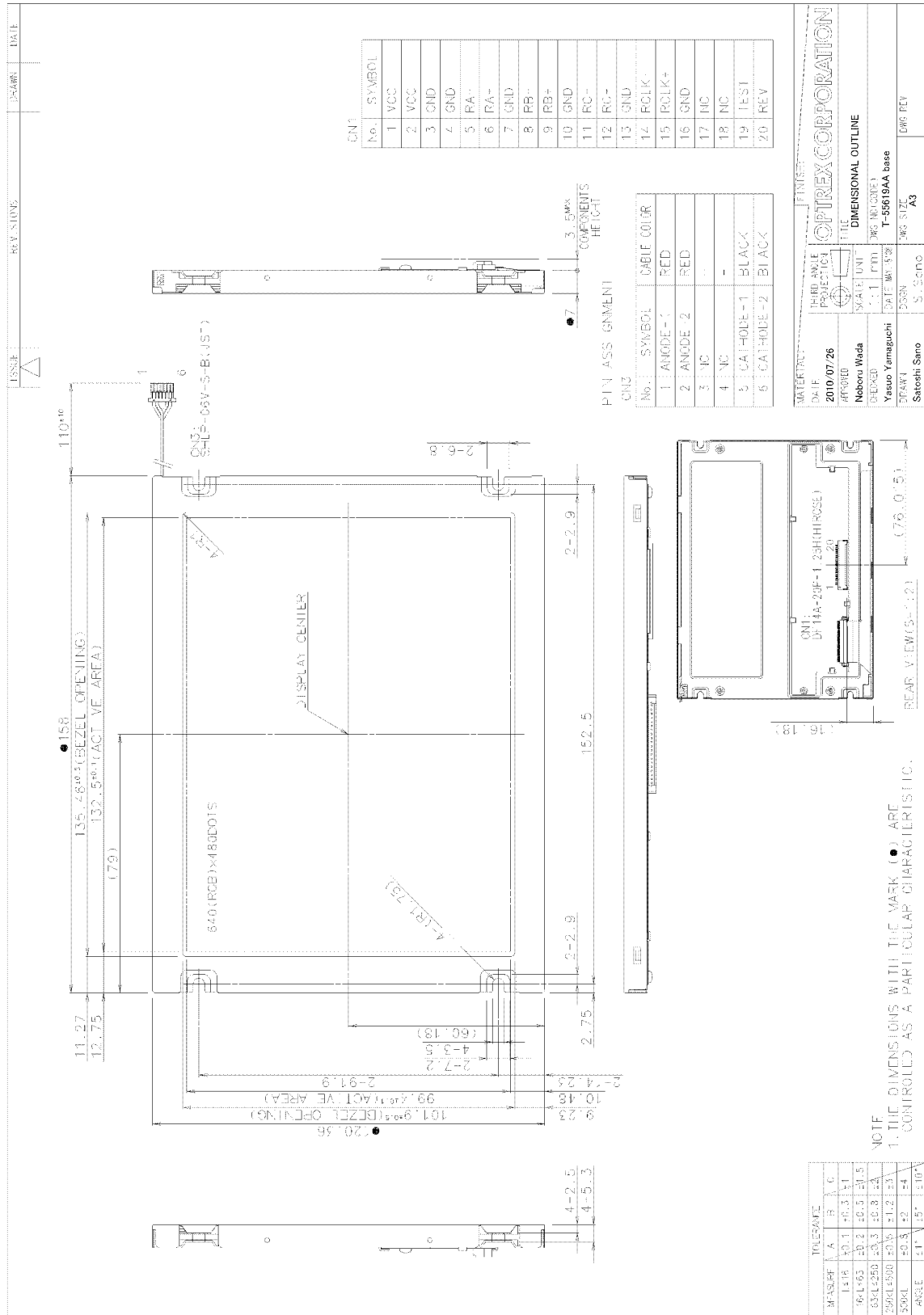

MESSAGE	A	B	C
1.516	±0.1	±0.3	±1
6.1~65	±0.2	±0.5	±0.5
65.1~250	±0.3	±0.8	±1
250.1~500	±0.5	±1.2	±1.5
500.1	±0.8	±2	±4
ANGLE	±1°	±5'	±10"

NOTE
 1. THE DIMENSIONS WITH THE MARK (●) ARE CONTROLLED AS A PARTICULAR CHARACTERISTIC.

Confidential

5. Block Diagram (ブロック図)

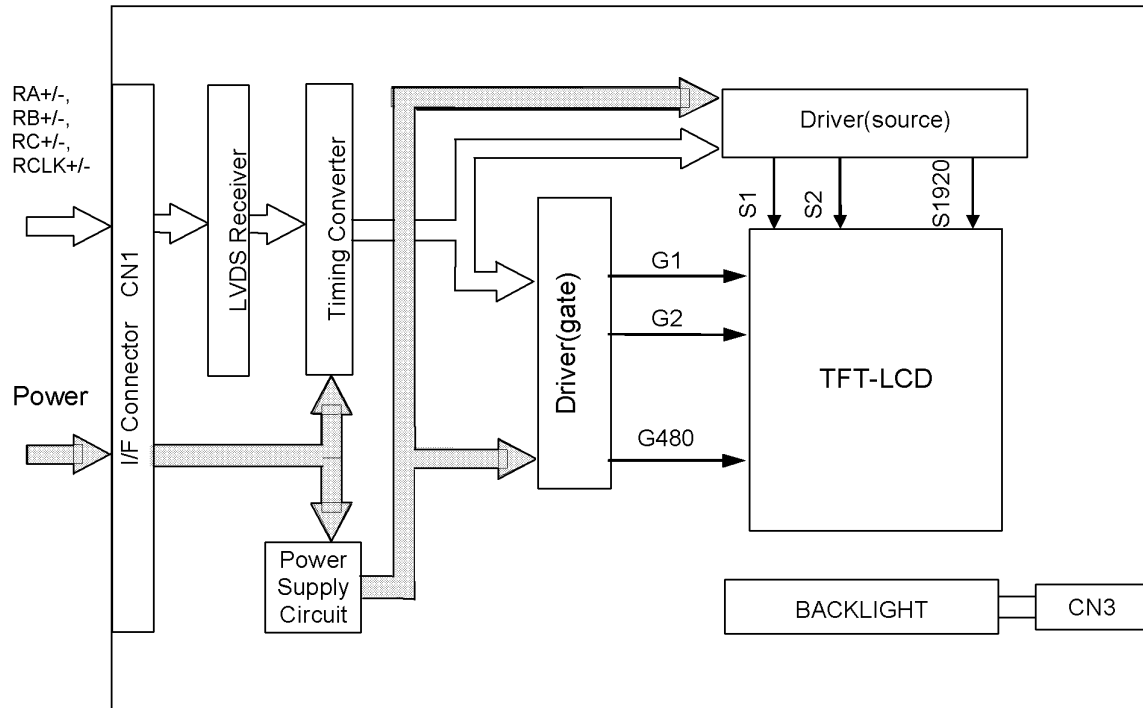

6. I/O Terminal (I / O 端子)

6.1. CN1 Pin Assignment (CN1 端子名)

INTERFACE SIGNAL (インターフェース信号)

Used connector(使用コネクタ): DF14A-20P-1.25H(56) (HIROSE)

Corresponding connector(適合コネクタ): DF14-20S-1.25C (HIROSE)

No.	Symbol(記号)	Functional Description (機能説明)
1	VCC	Power Supply (電源) (DC 3.3V)
2	VCC	Power Supply (電源) (DC 3.3V)
3	GND	Power Supply (電源) (0V, GND)
4	GND	Power Supply (電源) (0V, GND)
5	RA-	LVDS Data Input R0, R1, R2, R3, R4, R5, G0
6	RA+	LVDS Data Input R0, R1, R2, R3, R4, R5, G0
7	GND	Power Supply (電源) (0V, GND)
8	RB-	LVDS Data Input G1, G2, G3, G4, G5, B0, B1
9	RB+	LVDS Data Input G1, G2, G3, G4, G5, B0, B1
10	GND	Power Supply (電源) (0V, GND)
11	RC-	LVDS Data Input B2, B3, B4, B5, HD, VD, DENA
12	RC+	LVDS Data Input B2, B3, B4, B5, HD, VD, DENA
13	GND	Power Supply (電源) (0V, GND)
14	RCLK-	LVDS Clock Input
15	RCLK+	LVDS Clock Input
16	GND	Power Supply (電源) (0V, GND)
17	NC	Non Connection (未使用端子)
18	NC	Non Connection (未使用端子)
19	TEST	This pin should be open. Test signal output for only internal test use. (テスト信号出力端子(システム側でオープンにして下さい))
20	REV	Reverse scans control. L = Normal, H = Reverse (表示方向切換え。L=通常走査、H=逆走査)

Note(注): The shielding case is connected with GND (フレームは GND に接続されています。)

6.2. CN 3 Pin Assignment (CN3 端子名)

Used connector(使用コネクタ): SHLP-06V-S-B (JST)

Corresponding connector(適合コネクタ): SM06-SHLS-TF (LF)(SN)(JST)

No.	Symbol(記号)	Functional Description (機能説明)
1	ANODE-1(RED)	LED Anode Terminal (LED アノード端子)
2	ANODE-2(RED)	LED Anode Terminal (LED アノード端子)
3	NC	Non Connection (未使用端子)
4	NC	Non Connection (未使用端子)
5	CATHODE-1(BLACK)	LED Cathode Terminal (LED カソード端子)
6	CATHODE-2(BLACK)	LED Cathode Terminal (LED カソード端子)

6.3.ISP data mapping

a. ISP 6 bit compatibility mode (6 bit input)

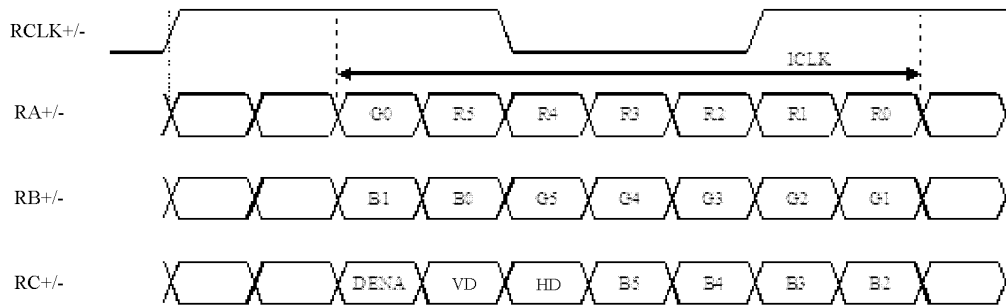

7. Electrical Specifications (電氣的仕様)

7.1. Absolute Maximum Ratings (絶対最大定格)

Ta=-20~70°C, GND=0V

Parameter (項目)	Symbol (記号)	Conditions (条件)	Min.	Max.	Units (単位)
Supply Voltage for LCD	VCC	-	0	4.0	V
Logic Input Voltage	VI	-	-0.3	4.0	V

7.2. DC Characteristics (DC特性)

Ta=-20~70°C, GND=0V

Parameter (項目)	Symbol (記号)	Conditions (条件)	Min.	Typ.	Max.	Units (単位)	
Power Supply Voltages for LCD (LCD電源電圧)	VCC	for 3.3V system (3.3V系駆動時)	3.0	3.3	3.6	V	
Power Supply Currents for LCD (LCD電源電流)	ICC	for 3.3V system (3.3V系駆動時)	--	310	465	mA	
CMOS/TTL Input Voltage (CMOS/TTL入力電圧)	High	VCC=MAX	VIH	2.0	--	VCC	V
	Low	VCC=MIN	VIL	0	--	0.8	V
CMOS/TTL Output Voltage (CMOS/TTL出力電圧)	High	VCC=MAX	VIH	2.4	--	--	V
	Low	VCC=MIN	VIL	--	--	0.4	V

7.3.Interface Timing

7.3.1.LVDS transmitter input signal

Parameter (項目)		Symbol (記号)	Min.	Typ.	Max.	Units (単位)
DCLK	Frequency (周波数)	f_{CLK}	20	25	30	MHz
	Period (周期)	t_{CLK}	33.3	40	50	ns
	Low Width (パルス幅(Low))	t_{WCL}	10	--	--	ns
	High Width (パルス幅(High))	t_{WCH}	10	--	--	ns
DATA (R,G,B,DENA, HD, VD)	Set up time (セットアップ時間)	t_{DS}	5	--	--	ns
	Hold time (保持時間)	t_{DH}	5	--	--	ns
DENA	Horizontal Active Time (水平表示時間)	t_{HA}	640	640	640	t_{CLK}
	Horizontal Front Porch (水平フロントポーチ)	t_{HFP}	0	--	--	t_{CLK}
	Horizontal Back Porch (水平バックポーチ)	t_{HBP}	7	--	--	t_{CLK}
	Vertical Active Time (垂直表示時間)	t_{VA}	480	480	480	t_H
	Vertical Front Porch (垂直フロントポーチ)	t_{VFP}	1	20	--	t_H
	Vertical Back Porch (垂直バックポーチ)	t_{VBP}	8	20	--	t_H
HD	Frequency (周波数)	f_H	27	31.5	38	kHz
	Period (周期)	t_H	26.3	31.7	37.0	μs
	Low Width (パルス幅(Low))	t_{WHL}	5	--	--	t_{CLK}
VD	Frequency (周波数)	f_V	55	60	70	Hz
	Period (周期)	t_V	14.3	16.7	18.2	ms
	Low Width (パルス幅(Low))	t_{WVL}	3	--	--	t_H

[Note](注)

- 1) DATA is latched at fall edge of DCLK in this timing specification.
(DATAはDCLKの立ち下がりエッジで取り込みます。)
- 2) Polarities of HD and VD are negative in this specification.
(HDとVDは負極性です。)
- 3) DENA (Data Enable) should always be positive polarity as shown in the timing specification.
(DENA(データイネーブル)は常に正極性です。)
- 4) DCLK should appear during all invalid period, and HD should appear during invalid period of frame cycle.
(DCLKは全ブランク期間にも入力が必要です。また、HDは垂直ブランク期間にも入力が必要です。)
- 5) Accepted only 640 data and 480 lines.
(640ドット、480ライン分のデータのみ対応です。)
- 6) REV should be stable during operation.
(REVは動作中に変更しないで下さい。)
- 7) LVDS timing follows the timing specifications of LVDS receiver IC:THC63LVDF84B(Thine).
(LVDSのタイミングについては、LVDSのレシーバーIC:THC63LVDF84B(Thine)の仕様書に従って下さい。)

7.4. Timing Chart (タイミングチャート)

a. Pixel Timing Chart (ピクセルタイミングチャート)

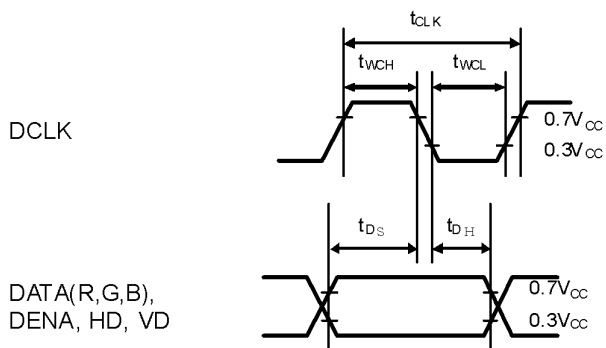

b. Horizontal Timing Chart (水平タイミングチャート)

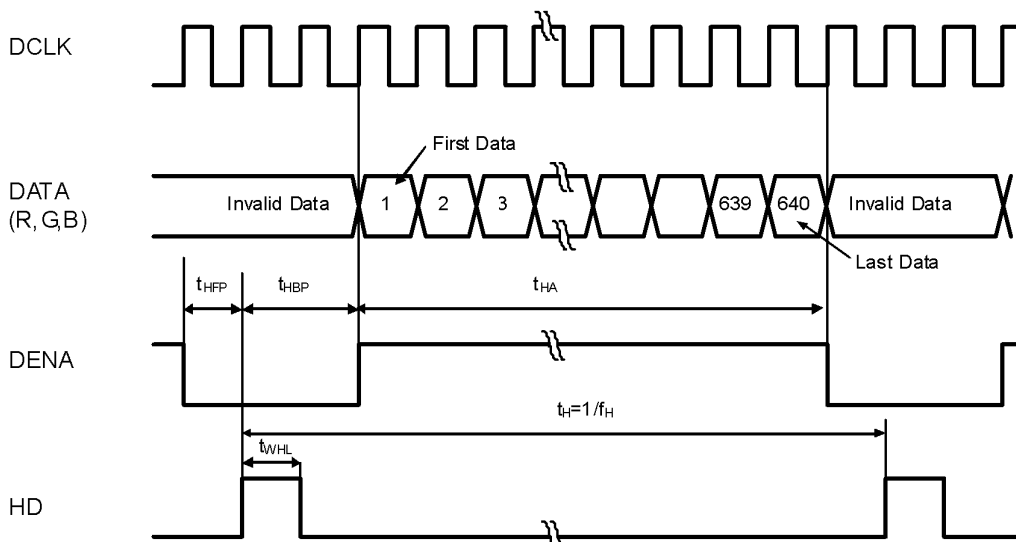

c. Vertical Timing Chart (垂直タイミングチャート)

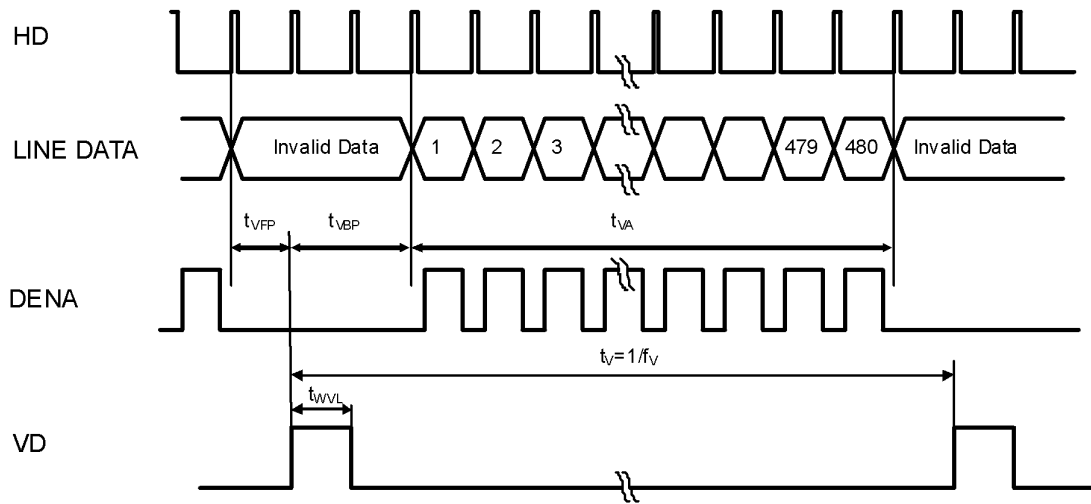

7.5.Pixel Alignment (画素配列)

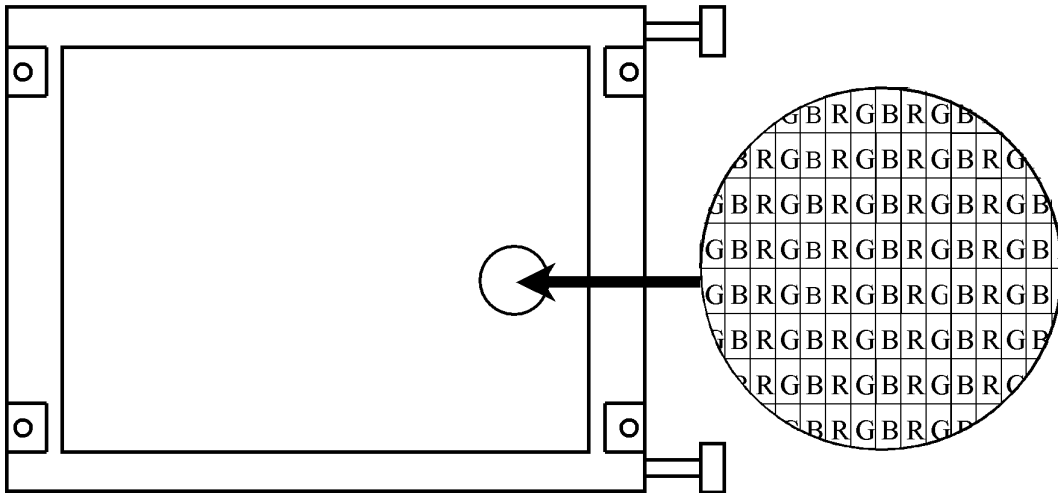

7.6.Color Data Assignment (カラーデータ設定表)

COLOR	INPUT DATA	R DATA						G DATA						B DATA					
		MSB			LSB			MSB			LSB			MSB			LSB		
		R5	R4	R3	R2	R1	R0	G5	G4	G3	G2	G1	G0	B5	B4	B3	B2	B1	B0
BASIC COLOR	BLACK	0	0	0	0	0	0	0	0	0	0	0	0	0	0	0	0	0	0
	RED (63)	1	1	1	1	1	1	0	0	0	0	0	0	0	0	0	0	0	0
	GREEN (63)	0	0	0	0	0	0	1	1	1	1	1	1	0	0	0	0	0	0
	BLUE (63)	0	0	0	0	0	0	0	0	0	0	0	0	1	1	1	1	1	1
	CYAN	0	0	0	0	0	0	1	1	1	1	1	1	1	1	1	1	1	1
	MAGENTA	1	1	1	1	1	1	0	0	0	0	0	0	1	1	1	1	1	1
	YELLOW	1	1	1	1	1	1	1	1	1	1	1	1	0	0	0	0	0	0
	WHITE	1	1	1	1	1	1	1	1	1	1	1	1	1	1	1	1	1	1
RED	RED (0)	0	0	0	0	0	0	0	0	0	0	0	0	0	0	0	0	0	0
	RED (1)	0	0	0	0	0	1	0	0	0	0	0	0	0	0	0	0	0	0
	RED (2)	0	0	0	0	1	0	0	0	0	0	0	0	0	0	0	0	0	0
	RED (62)	1	1	1	1	1	0	0	0	0	0	0	0	0	0	0	0	0	0
	RED (63)	1	1	1	1	1	1	0	0	0	0	0	0	0	0	0	0	0	0
GREEN	GREEN (0)	0	0	0	0	0	0	0	0	0	0	0	0	0	0	0	0	0	0
	GREEN (1)	0	0	0	0	0	0	0	0	0	0	1	0	0	0	0	0	0	0
	GREEN (2)	0	0	0	0	0	0	0	0	0	1	0	0	0	0	0	0	0	0
	GREEN (62)	0	0	0	0	0	0	1	1	1	1	1	0	0	0	0	0	0	0
GREEN (63)	0	0	0	0	0	0	1	1	1	1	1	1	0	0	0	0	0	0	
BLUE	BLUE (0)	0	0	0	0	0	0	0	0	0	0	0	0	0	0	0	0	0	0
	BLUE (1)	0	0	0	0	0	0	0	0	0	0	0	0	0	0	0	0	0	1
	BLUE (2)	0	0	0	0	0	0	0	0	0	0	0	0	0	0	0	0	1	0
	BLUE (62)	0	0	0	0	0	0	0	0	0	0	0	0	1	1	1	1	1	0
	BLUE (63)	0	0	0	0	0	0	0	0	0	0	0	0	1	1	1	1	1	1

[Note] (注)

1) Definition of gray scale (階調定義)

Color (n) --- n indicates gray scale level. (nは階調レベルを示します。)

Higher n means brighter level. (より高いnはより明るいレベルを意味します。)

2) Data 1:High, 0: Low

7.7. Inverted Scan Capability (スキャン反転機能)

This module has the capability of inverting scan direction by signaling from controller.

Note: Scan direction cannot be changed during operation.

(このモジュールには、コントローラから信号により走査方向を逆にすることができます。)

(注：スキャン方向の動作中の変更はできません。)

The following figure shows the relation between the display position and the scan direction.

(以下の図は、視認方向とスキャン方向の関係を表します。)

Normal scan(通常スキャン): REV = "L"

D(1, 1)	D(2, 1)	---	D(X, 1)	---	D(639, 1)	D(640, 1)
D(1, 2)	D(2, 2)	---	D(X, 2)	---	D(639, 2)	D(640, 2)
↓	↓	+	+	+	↓	↓
D(1, Y)	D(2, Y)	---	D(X, Y)	---	D(639, Y)	D(640, Y)
↓	↓	+	+	+	↓	↓
D(1,479)	D(2,479)	---	D(X,479)	---	D(639,479)	D(640,479)
D(1,480)	D(2,480)	---	D(X,480)	---	D(639,480)	D(640,480)

Reverse scan(反転スキャン): REV = "H"

D(640,480)	D(639,480)	---	D(X,480)	---	D(2,480)	D(1,480)
D(640,479)	D(639,479)	---	D(X,479)	---	D(2,479)	D(1,479)
↓	↓	+	+	+	↓	↓
D(640, Y)	D(639, Y)	---	D(X, Y)	---	D(2, Y)	D(1, Y)
↓	↓	+	+	+	↓	↓
D(640, 2)	D(639, 2)	---	D(X, 2)	---	D(2, 2)	D(1, 2)
D(640, 1)	D(639, 1)	---	D(X, 1)	---	D(2, 1)	D(1, 1)

The following drawing shows the relationship between the viewing direction and the scan direction.

(次の図は、見る方向と走査方向の関係を示します。)

Normal scan (通常スキャン)

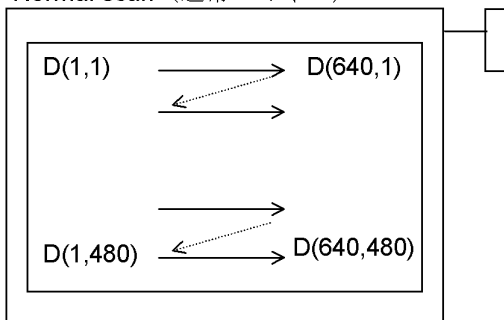

Reverse scan (反転スキャン)

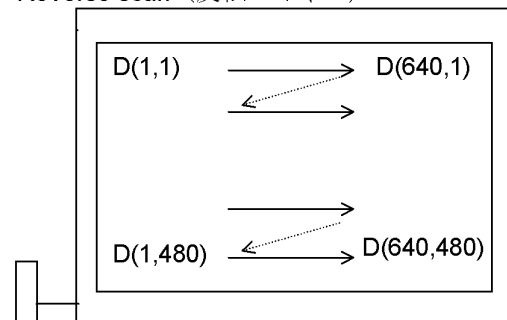

7.8. Lighting Specifications (照明仕様)

7.8.1. Absolute Maximum Ratings (絶対最大定格)

Ta=25°C

Parameter(項目)	Symbol(記号)	Conditions(条件)	Min.	Typ.	Max.	Units(単位)
Forward Current (順電流)	I _F	Note 2	-	-	150	mA
Allowable Reverse Current (逆方向許容電流)	I _R	-	-	-	85	mA
LED Power Dissipation (許容損失)	P _D	-	-	-	540	mW

Note 1 : This value is for each 1 line. (1列あたりの値を示します。)

Note 2 : Refer to the forward current derating curve. (ディレーティングカーブを下図に示す。)

【Forward Current Derating Curve (電流軽減特性)】

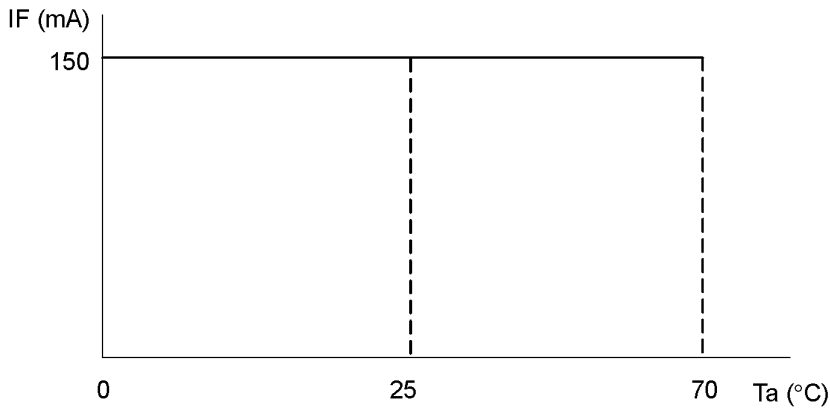

【LED Circuit (LED 回路)】

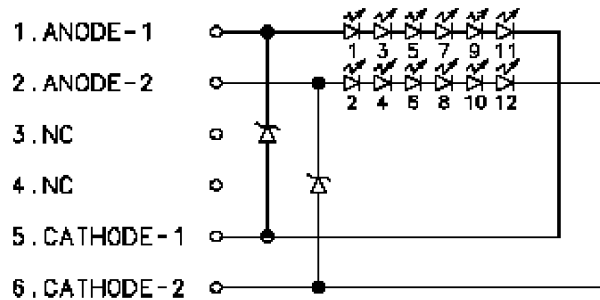

7.8.2. Operating Characteristics (動作定格)

Ta=25°C

Parameter(項目)	Symbol(記号)	Conditions(条件)	Min.	Typ.	Max.	Units(単位)
Forward Voltage (順電圧)	V _F	I _F = 80mA / line	-	16.0	18.0	V
LED Lifetime (寿命)		Note1	50000	-	-	Hr

Note1: The "Lifetime" is defined as: a decline of brightness to 50% of initial brightness (500cd/m²) under continual Ta=25°C.

8. Optical Specifications (光学仕様)

8.1. Optical Characteristic (光学特性)

Item (項目)	Symbol (記号)	Conditions(条件)			Standard Value(規格値)			Unit (単位)	Method of Measure (測定法)	Remark (備考)
		θ	ϕ	C	Min.	Typ.	Max.			
(1) Brightness(輝度)	B	0°	0°	/	-	750		Cd/m ²	(Fig.1)	Note1
(2) Contrast(コントラスト)	CR	Optimum Viewing Angle 最適視角 での値			150	300	-	-		
(3) Color Coordinates (色度)	Red	Rx	0°	0°	/	0.52	0.55	0.58		-
		Ry	0°	0°	/	0.32	0.35	0.38		-
	Green	Gx	0°	0°	/	0.34	0.37	0.40		-
		Gy	0°	0°	/	0.53	0.56	0.59		-
	Blue	Bx	0°	0°	/	0.12	0.15	0.18		-
		By	0°	0°	/	0.11	0.14	0.17	-	
	White	Wx	0°	0°	/	0.28	0.32	0.36	-	
Wy		0°	0°	/	0.31	0.35	0.39	-		
(4) Brightness Uniformity (輝度ムラ)	-	0°	0°	/	0.7	-	-	-	(Fig.2)	
(5) Vertical Viewing Angle (垂直視野角)	Up	θ_U	-	0°	≥ 10	-	30	-	Degree	(Fig.3)
	Down	θ_D	-	0°	≥ 10	-	60	-	Degree	
(6) Horizontal Viewing Angle (水平視野角)	Left	ϕ_L	0°	-	≥ 10	-	55	-	Degree	
	Right	ϕ_R	0°	-	≥ 10	-	55	-	Degree	
(7) Response Time(応答時間)	Rise	τ_r	0°	0°	/	-	15	-	ms	(Fig.4)
	Decay	τ_d	0°	0°	/	-	16	-	ms	
(8) Haze(ヘイズ)	H	/			-	9	-	%		

Note1: Under the condition of IF=60mA/chip, Ta=25°C

- ◆ Conditions for Measuring
 - ◇ Environment: Dark room with no light or close to no light.
 - ◇ Temperature: 25±5°C
 - ◇ Humidity: 40~70%RH
- ◆ 測定条件は下記の通り
 - ◇ 測定環境: 暗室またはそれに準じる環境
 - ◇ 測定温度: 25±5°C
 - ◇ 測定湿度: 40~70%RH
- ◆ Optimal viewing angle (The angle with best contrast)
- ◆ 主視角方向 (コントラストが最大となる方向)

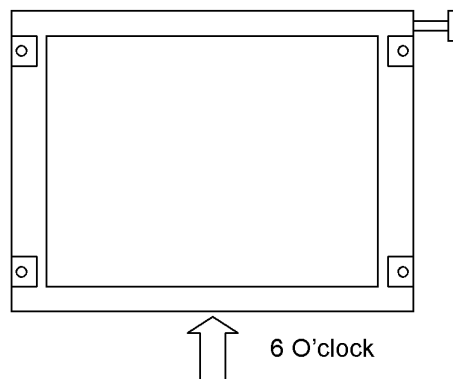

◆ Method of Brightness Measurement (輝度測定法) (Fig.1)

(1) Measuring Device (測定装置)

TOPCON BM-5, Measuring Field: 1°

(2) Measuring Point (測定点)

Center of Display $\theta=0^\circ, \phi=0^\circ$

On condition θ : A vertical angle from measuring direction to perpendicular.

ϕ : A horizontal angle from measuring direction to perpendicular.

画面中央部 $\theta=0^\circ, \phi=0^\circ$

ただし、 θ : 法線に対する視角面の垂直軸方向の角度

ϕ : 法線に対する視角面の水平軸方向の角度

(3) Method of Measuring (測定方法)

Apply signal voltage (displayed in white) to maximize brightness and measure brightness B (cd/m^2).

The distance between BM-5's front lens to surface panel is 500mm.

Measured after backlight has been lit for more than 30 minutes.

輝度が最大となる信号電圧 (白表示) を印加し、輝度 B (cd/m^2) を測定する。

測定距離は BM-5 レンズ前面よりパネル表面まで 500mm として測定する。

バックライト点灯 30 分以上経過後に測定する。

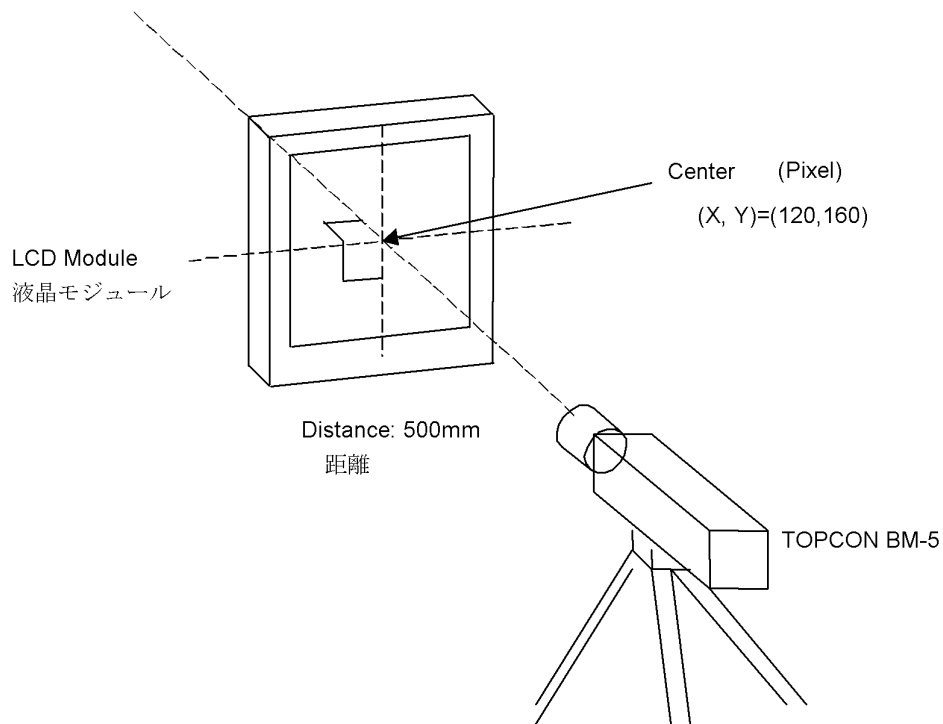

Fig. 1

◆ Method of Contrast Measurement (コントラスト測定法) (Fig.1)

- (1) Measuring Device (測定装置)
TOPCON BM-5, Measuring Field: 1°
- (2) Measuring Point (測定点)
Center of display: same as Method of Brightness Measurement
画面中央部：輝度測定点と同様
- (3) Method of Measuring (測定方法)
 - Set LCD module to $\theta=0^\circ, \phi=0^\circ$.
(液晶表示モジュールを $\theta=0^\circ, \phi=0^\circ$ にセットする。)
 - Change signal voltage to measure maximum brightness Y1 and minimum brightness Y2.
(信号電圧を変化させ、最大輝度 Y1、最小輝度 Y2 を測定する。)
 - Contrast is derived from $CR=Y1/Y2$.
($CR=Y1 / Y2$ をコントラストとする。)

◆ Definition of Brightness Uniformity (輝度むらの定義) (Fig.2)

Definition is calculated from the 5 points (S0-S4) on the diagram below.

下図に示す点 (S0~S4) の測定点で、下記の計算式にて定義する。

$$\text{Standard value of Brightness Uniformity}[\%] = \frac{\text{S0~S4 MIN (最小値)}}{\text{S0~S4 MAX (最大値)}} \times 100$$

(輝度むらの規格値)

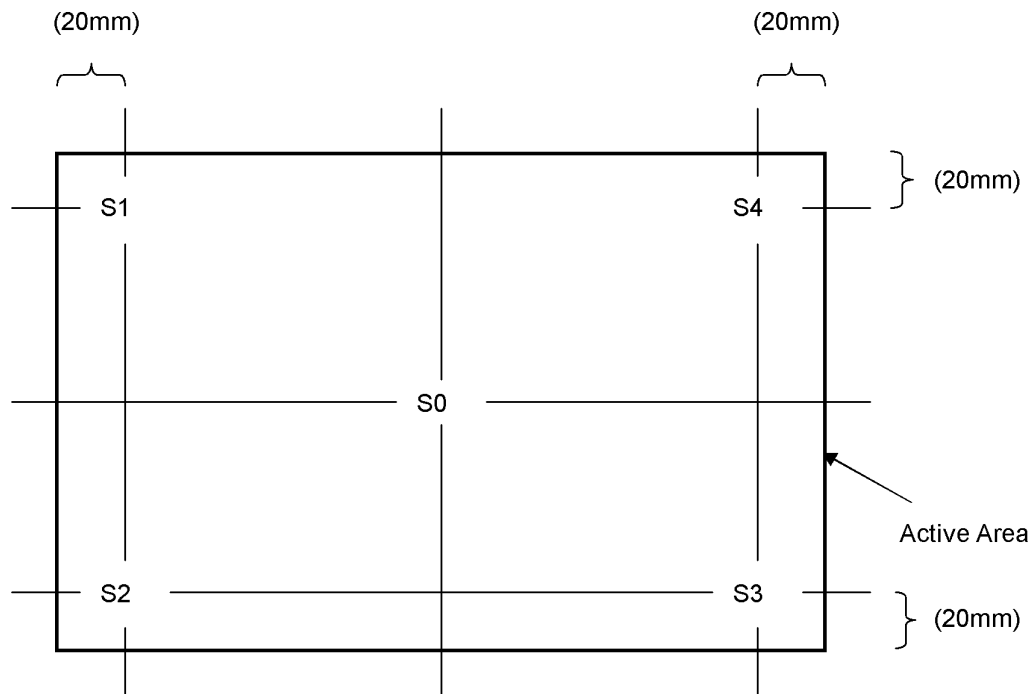

Fig. 2

◆ Method of Viewing Angle Measurement (視野角測定法) (Fig.3)

(1) Measuring Device (測定装置)

TOPCON BM-5, Measuring Field: 1°

(2) Measuring Point (測定点)

Center of display: Same as Method of Brightness Measurement

画面中央部：輝度測定点と同様

(3) Angle of Measuring (測定角度)

θ : An angle vertical to perpendicular line from the viewing direction.

θ : 法線に対する視角面の垂直軸方向の角度

ϕ : An angle horizontal to perpendicular from the viewing direction.

ϕ : 法線に対する視角面の水平軸方向の角度

(4) Method of Measuring (測定方法)

Set rotation table to $\phi=0^\circ$ and set BM-5 to contrast 10 to measure angle $\pm\theta$ for left and right direction of horizontal viewing angle ϕ . Also set rotation table to $\phi=90^\circ$ and set BM-5 to contrast 10 to measure angle $\pm\theta$ for up and down direction of vertical viewing angle θ .

回転ステージの $\phi=0^\circ$ に固定して BM-5 がコントラスト 10 となる $\pm\theta$ 角度を読み取り左右方向の水平視野角 ϕ 、回転ステージの $\phi=90^\circ$ に固定して BM-5 がコントラスト 10 となる $\pm\theta$ 角度を読み取り上下方向の垂直視野角 θ として記録する。

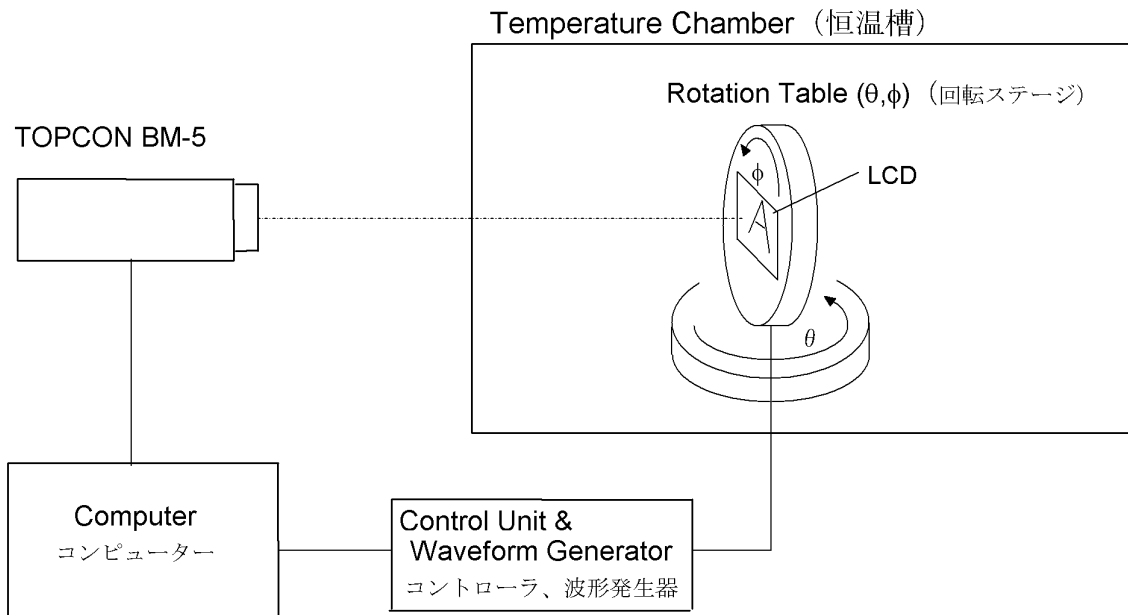

Fig. 3

◆ Measuring Response Time (応答時間の測定) (Fig.4)

(1) Measuring Device (測定装置)

TOPCON BM-5 , Measuring Field: 1°

Tektronix Digital Oscilloscope

テクトロニクス社製 デジタルオシロスコープ

(2) Measuring Point (測定点)

Center of display, same as Method of Brightness Measurement

画面中央部：輝度測定点と同様

(3) Method of Measuring (測定方法)

- Set LCD panel to $\theta=0^\circ$, and $\phi=0^\circ$.

液晶表示パネルを $\theta=0^\circ$ 、 $\phi=0^\circ$ にセットする。

- Input white→black→white to display by switching signal voltage.

白→黒→白と表示するように表示信号電圧を切り替えて印加する。

- If the luminance is 0% and 100% immediately before the change of signal voltage, then τ_r is optical response time during the change from 90% to 10% immediately after rise of signal voltage, and τ_d is optical response time during the change from 10% to 90% immediately after decay of signal voltage.

信号電圧切り替え直前の輝度をそれぞれ 0%、100%とすると、表示信号立ち上り後、光学応答が 90%から 10%に変化するのにかかる時間を τ_r とし、表示信号立ち下がり後、光学応答が 10%から 90%にまで変化する時間を τ_d とする。

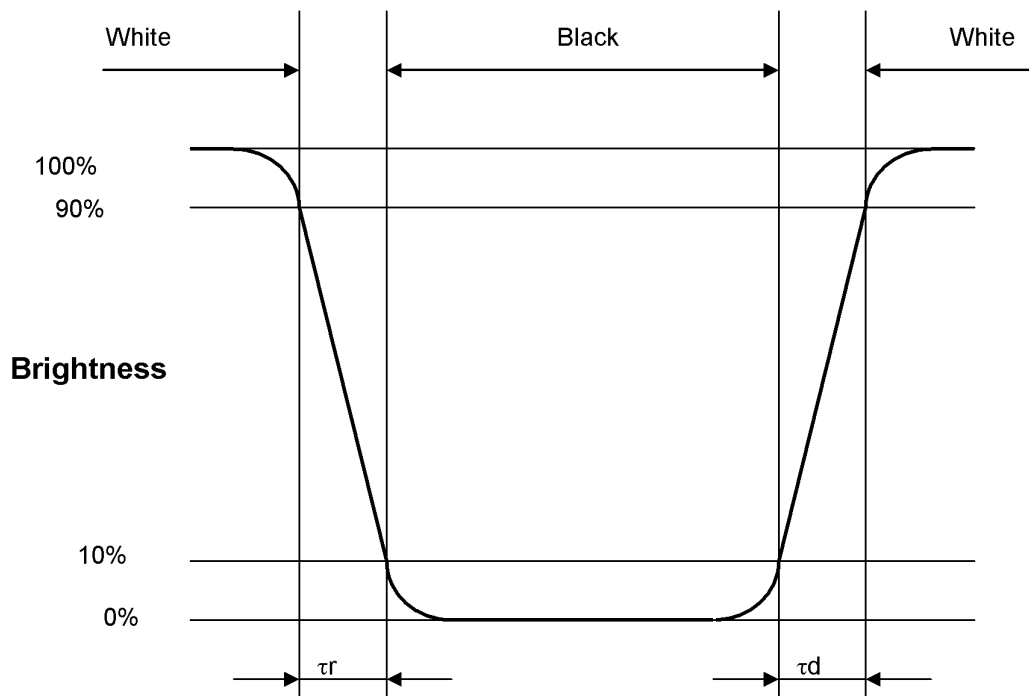

Fig. 4

9. Test (試験)

No abnormal function and appearance are found after the following tests.

下記の試験を実施した後、表示及び動作に異常がないこと。

Conditions: Unless otherwise specified, tests will be conducted under the following condition.

Temperature: 20±5°C

Humidity : 65±5%RH

tests will be not conducted under functioning state.

条件：特に指定の無い限り、温度 20±5°C、湿度 65±5%、無通電状態で行う。

No.	Parameter(項目)	Conditions (試験内容)	Notes(注記)
1	High Temperature Operating (高温動作試験)	70°C±2°C, 96hrs (operation state) (通電)	
2	Low Temperature Operating (低温動作試験)	-20°C±2°C, 96hrs (operation state) (通電)	1
3	High Temperature Storage (高温保存試験)	70°C±2°C, 96hrs	2
4	Low Temperature Storage (低温保存試験)	-20°C±2°C, 96hrs	1,2
5	Damp Proof Test (耐湿試験)	40°C±2°C, 90~95%RH, 96hrs	1,2
6	Vibration Test (振動試験)	Frequency:10-57Hz/Vibration width(one side):0.75mm :58-500Hz/Gravity:9.8m/s ² Sweep time:11 minutes Test period:3hrs for each direction of X,Y,Z 振動周波数 : 10~57Hz, 片振幅 : 0.075mm : 58-500Hz, 加速度 : 9.8m/s ² 掃引時間 : 11 分間 試験時間 3 時間, X,Y,Z 各方向 1 時間	3
7	Shock (衝撃)	Shock level:490m/s ² Waveform:half sinusoidal wave, 11ms Number of shocks : One shock input in each direction of three perpendicular axis for a total of six shock inputs 最高加速度 : 490m/s ² 正弦半波, t=11ms 回数 : 1 回 / 1 方向, ±X, ±Y, ±Z 各方向	

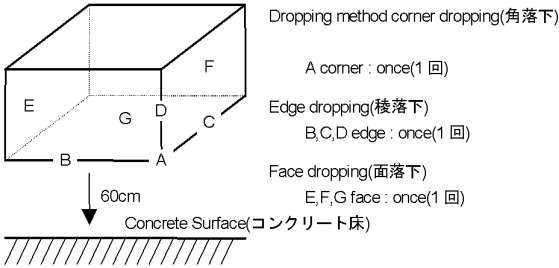
No.	Parameter(項目)	Conditions (試験内容)	Notes(注記)
9	Shock Test	<p>To be measured after dropping from 60cm high on the concrete surface in packing state. (正規の梱包状態にて 60cm の高さから下記の要領でコンクリート床へ落下)</p> 	
<p>Note 1: No dew condensation to be observed. Note 2: The function test shall be conducted after 4 hours storage at the normal Temperature and humidity after removed from the test chamber. Note 3: Vibration test will be conducted to the product itself without putting it in a container. 注 1 : 結露しないこと。 注 2 : 試験後、常温常湿に 4 時間放置した後、測定する。 注 3 : 容器を用いずモジュール単品で行う。</p>			
T-55619GD065J-LW-AAN		OPTREX CORPORATION	Page 22/31

10. Appearance Standards (外觀規格)

10.1. Inspection conditions (外觀検査条件)

The distance between the eyes and the sample shall be more than 30cm.

All directions for inspecting the sample should be within 45° against perpendicular line.

サンプルとの距離 30cm 以上で目視により検査を行う。

サンプルを目視する方向は、垂線に対して前後左右 45° の範囲内とする。

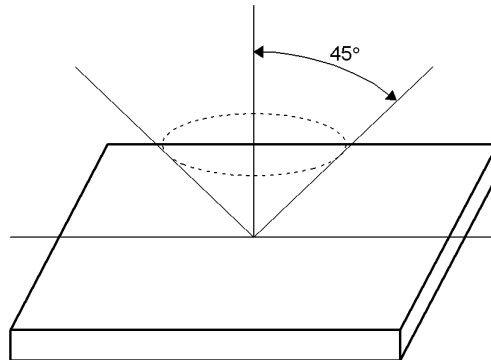

10.2. Definition of applicable Zones (サンプルの適用ゾーンの定義)

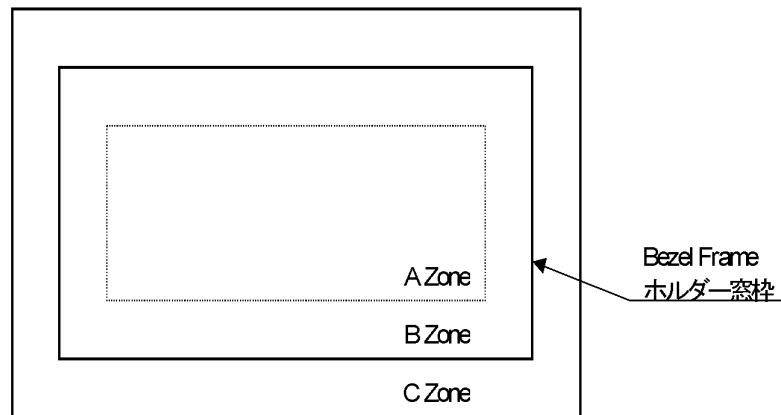

A Zone : Active display area

B Zone : Area from outside of "A Zone" to validity viewing area

C Zone : Rest parts

A Zone + B Zone = Validity viewing area

Aゾーン : ドット部

Bゾーン : ドットとホルダー窓枠に挟まれた部分

Cゾーン : その他の部分

Aゾーン+Bゾーン=有効視野範囲

10.3.Standards (規格)

No.	Parameter (項目)	Criteria (判定基準)																									
1	Polarizer Scratches (直線状のキズ)	<table border="1"> <thead> <tr> <th colspan="2">Zone(領域)</th> <th colspan="3">Acceptable Number(許容個数)</th> </tr> <tr> <th>X(mm)</th> <th>Y(mm)</th> <th>A</th> <th>B</th> <th>C</th> </tr> </thead> <tbody> <tr> <td>$L \leq 15$</td> <td>$0.01 < W \leq 0.05$</td> <td colspan="2">4</td> <td>*</td> </tr> <tr> <td>$L > 15$</td> <td>$W > 0.01$</td> <td colspan="2">0</td> <td>*</td> </tr> <tr> <td>-</td> <td>$W > 0.05$</td> <td colspan="2">0</td> <td>*</td> </tr> </tbody> </table> <p>X : Length(長さ), Y : Width(幅) * : Disregard(無視)</p>	Zone(領域)		Acceptable Number(許容個数)			X(mm)	Y(mm)	A	B	C	$L \leq 15$	$0.01 < W \leq 0.05$	4		*	$L > 15$	$W > 0.01$	0		*	-	$W > 0.05$	0		*
Zone(領域)		Acceptable Number(許容個数)																									
X(mm)	Y(mm)	A	B	C																							
$L \leq 15$	$0.01 < W \leq 0.05$	4		*																							
$L > 15$	$W > 0.01$	0		*																							
-	$W > 0.05$	0		*																							
2	DENT (円形状のキズ)	<table border="1"> <thead> <tr> <th>Zone(領域)</th> <th colspan="3">Acceptable Number(許容個数)</th> </tr> <tr> <th>Dimension (大きさ) (mm)</th> <th>A</th> <th>B</th> <th>C</th> </tr> </thead> <tbody> <tr> <td>$0.30 < D \leq 0.50$</td> <td colspan="2">4</td> <td>*</td> </tr> <tr> <td>$0.50 < D$</td> <td colspan="2">0</td> <td>*</td> </tr> </tbody> </table> <p>Average Diameter(D) = (long+short)/2 * : Disregard(無視) 平均直径(D) = (長径+短径) / 2</p>	Zone(領域)	Acceptable Number(許容個数)			Dimension (大きさ) (mm)	A	B	C	$0.30 < D \leq 0.50$	4		*	$0.50 < D$	0		*									
Zone(領域)	Acceptable Number(許容個数)																										
Dimension (大きさ) (mm)	A	B	C																								
$0.30 < D \leq 0.50$	4		*																								
$0.50 < D$	0		*																								
3	BLACK and WHITE SPOT BUBBLE (円形状の黒い異物 気泡)	<table border="1"> <thead> <tr> <th>Zone(領域)</th> <th colspan="3">Acceptable Number(許容個数)</th> </tr> <tr> <th>Dimension (大きさ) (mm)</th> <th>A</th> <th>B</th> <th>C</th> </tr> </thead> <tbody> <tr> <td>$0.30 < D \leq 0.50$</td> <td colspan="2">5</td> <td>*</td> </tr> <tr> <td>$0.50 < D$</td> <td colspan="2">0</td> <td>*</td> </tr> </tbody> </table>	Zone(領域)	Acceptable Number(許容個数)			Dimension (大きさ) (mm)	A	B	C	$0.30 < D \leq 0.50$	5		*	$0.50 < D$	0		*									
Zone(領域)	Acceptable Number(許容個数)																										
Dimension (大きさ) (mm)	A	B	C																								
$0.30 < D \leq 0.50$	5		*																								
$0.50 < D$	0		*																								
4	LINT (繊維状の異物)	<table border="1"> <thead> <tr> <th colspan="2">Zone(領域)</th> <th colspan="3">Acceptable Number(許容個数)</th> </tr> <tr> <th>X(mm)</th> <th>Y(mm)</th> <th>A</th> <th>B</th> <th>C</th> </tr> </thead> <tbody> <tr> <td>$L \leq 3.0$</td> <td>$W \leq 0.15$</td> <td colspan="2">4</td> <td>*</td> </tr> <tr> <td>$L > 3.0$</td> <td>$W \leq 0.15$</td> <td colspan="2">0</td> <td>*</td> </tr> <tr> <td>-</td> <td>$W > 0.15$</td> <td colspan="2">According to BLACK SPOT (黒い異物のものによる)</td> <td>*</td> </tr> </tbody> </table> <p>X : Length(長さ), Y : Width(幅) * : Disregard(無視)</p>	Zone(領域)		Acceptable Number(許容個数)			X(mm)	Y(mm)	A	B	C	$L \leq 3.0$	$W \leq 0.15$	4		*	$L > 3.0$	$W \leq 0.15$	0		*	-	$W > 0.15$	According to BLACK SPOT (黒い異物のものによる)		*
Zone(領域)		Acceptable Number(許容個数)																									
X(mm)	Y(mm)	A	B	C																							
$L \leq 3.0$	$W \leq 0.15$	4		*																							
$L > 3.0$	$W \leq 0.15$	0		*																							
-	$W > 0.15$	According to BLACK SPOT (黒い異物のものによる)		*																							

No.	Parameter (項目)	Criteria (判定基準)																				
5	(a) Bright Dot (輝点) (b) Dark Dot (暗点)	<table border="1"> <thead> <tr> <th>Zone(領域)</th> <th colspan="3">Acceptable Number(許容個数)</th> </tr> <tr> <th>Dimension (大きさ) (mm)</th> <th>A</th> <th>B</th> <th>C</th> </tr> </thead> <tbody> <tr> <td>Bright Dot (輝点)</td> <td colspan="2">7 ($G \leq 3$)</td> <td>*</td> </tr> <tr> <td>Dark Dot (暗点)</td> <td colspan="2">7</td> <td>*</td> </tr> <tr> <td>TOTAL (合計)</td> <td colspan="3">10</td> </tr> </tbody> </table>	Zone(領域)	Acceptable Number(許容個数)			Dimension (大きさ) (mm)	A	B	C	Bright Dot (輝点)	7 ($G \leq 3$)		*	Dark Dot (暗点)	7		*	TOTAL (合計)	10		
		Zone(領域)	Acceptable Number(許容個数)																			
		Dimension (大きさ) (mm)	A	B	C																	
		Bright Dot (輝点)	7 ($G \leq 3$)		*																	
		Dark Dot (暗点)	7		*																	
TOTAL (合計)	10																					
6	TWO Adjacent Dot (2 連続点欠陥数)	<table border="1"> <thead> <tr> <th>Zone(領域)</th> <th colspan="3">Acceptable Number(許容個数)</th> </tr> <tr> <th>Dimension (大きさ) (mm)</th> <th>A</th> <th>B</th> <th>C</th> </tr> </thead> <tbody> <tr> <td>Bright Dot (輝点)</td> <td colspan="2">3 PAIRS</td> <td>*</td> </tr> <tr> <td>Dark Dot (暗点)</td> <td colspan="2">3 PAIRS</td> <td>*</td> </tr> </tbody> </table>	Zone(領域)	Acceptable Number(許容個数)			Dimension (大きさ) (mm)	A	B	C	Bright Dot (輝点)	3 PAIRS		*	Dark Dot (暗点)	3 PAIRS		*				
		Zone(領域)	Acceptable Number(許容個数)																			
		Dimension (大きさ) (mm)	A	B	C																	
		Bright Dot (輝点)	3 PAIRS		*																	
Dark Dot (暗点)	3 PAIRS		*																			
7	Three or More Adjacent Dot (3 連続点欠陥)	NOT ALLOWED (なきこと。)																				
8	Distance between the dot defects (点欠陥距離)	<table border="1"> <thead> <tr> <th>Zone(領域)</th> <th colspan="3">Acceptable Number(許容個数)</th> </tr> <tr> <th>Dimension (大きさ) (mm)</th> <th>A</th> <th>B</th> <th>C</th> </tr> </thead> <tbody> <tr> <td>Bright Dot (輝点)</td> <td colspan="2">5 mm</td> <td>*</td> </tr> <tr> <td>Dark Dot (暗点)</td> <td colspan="2">5 mm</td> <td>*</td> </tr> </tbody> </table>	Zone(領域)	Acceptable Number(許容個数)			Dimension (大きさ) (mm)	A	B	C	Bright Dot (輝点)	5 mm		*	Dark Dot (暗点)	5 mm		*				
		Zone(領域)	Acceptable Number(許容個数)																			
		Dimension (大きさ) (mm)	A	B	C																	
		Bright Dot (輝点)	5 mm		*																	
Dark Dot (暗点)	5 mm		*																			
9	Line Defect (線欠陥)	NOT ALLOWED (なきこと。)																				

Note 1: Bright Dot is defined as follows:

Visible through 5% transmission ND filter under the condition that black image (color 0) is on the display.

Note 2: Dark Dot is defined as follows:

Recognizable darker than around under the condition that each R(63), G(63), B(63) image is on the display.

Note 3: Definition of adjacent

注1: 輝点欠陥の定義:

全黒表示時に5%NDフィルターを通して見えるもの。

注2: 暗転の定義:

各 R (63) 、 G (63) 、 B (63) 表示時に、周囲より暗いと認識できるもの。

注3: 隣接の定義:

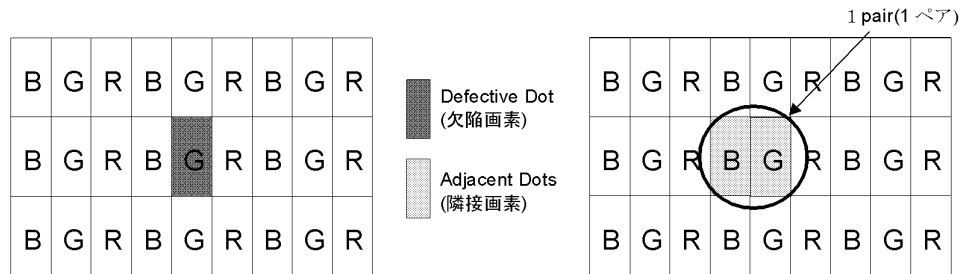

The defects that are not defined above and considered to be problem shall be reviewed and discussed by both parties.

この規格に記載のない事項で問題が発生した場合は別途協議の上決定し、記載する。

11. Code System of Production Lot (製造ロット番号)

The production lot of module is specified as follows.

モジュールの製造ロット番号は、次のように表記する。

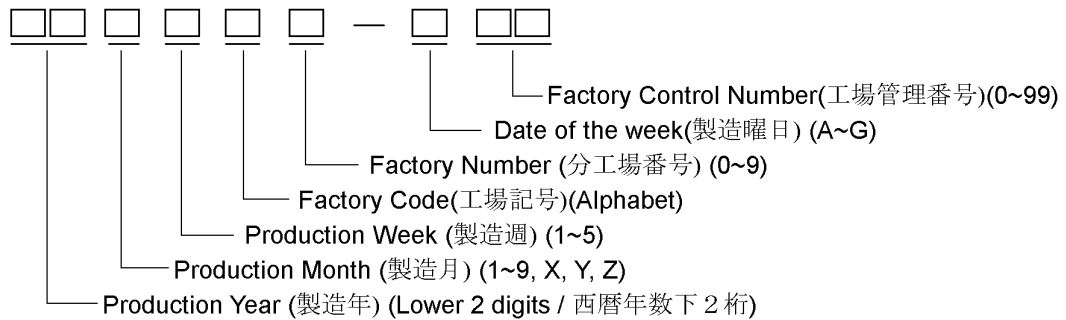

12. Type Number (製品型式)

The type number of module is specified as follows.

このモジュールの製品型式は、次のように表示する。

355619AA

13. Applying Precautions (運用上の注意)

Please contact us when questions and/or new problems not specified in this Specifications arise.

弊社仕様書に関する疑義、または記載項目以外の問題が発生した場合、両者協議の上処理することとする。

14. Precautions Relating Product Handling (製品取扱い上の注意)

The Following precautions will guide you in handling our product correctly.

弊社製品を正しくご使用頂く為に、次の事項にご注意下さい。

1) Liquid crystal display devices

- (1) The liquid crystal display panel used in the liquid crystal display module is made of plate glass. Avoid any strong mechanical shock. Should the glass break handle it with care.
- (2) The polarizer adhering to the surface of the LCD is made of a soft material. Guard against scratching it.

1) 液晶表示素子について

- (1) 液晶表示モジュールに使用している液晶表示素子は、板ガラスで作られていますので強い機械的衝撃を与えないで下さい。
割れが発生した場合は、危険ですから取り扱いには十分ご注意ください。
- (2) 液晶表示素子の表面に貼り付けてある偏光板は、軟らかい材料でできている為、傷をつけないようにして下さい。

2) Care of the liquid crystal display module against static electricity discharge.

- (1) When working with the module, be sure to ground your body and any electrical equipment you may be using. We strongly recommend the use of anti static mats (made of rubber), to protect worktables against the hazards of electrical shock.
- (2) Avoid the use of work clothing made of synthetic fibers. We recommend cotton clothing or other conductivity-treated fibers.
- (3) Slowly and carefully remove the protective film from the LCD module, since this operation can generate static electricity.

2) 液晶表示モジュールの取り扱いについて (静電対策)

- (1) 人体、電気設備には必ずアースをして下さい。また、作業台は万一の電撃ショック等の心配がある為、静電防止マット(ラバー)をお薦めします。
- (2) 作業衣は化繊を避けて、木綿か導電処理された繊維の使用をお薦めします。
- (3) 静電気が発生しますので、液晶表示板の保護フィルムはゆっくりと剥がして下さい。

3) When the LCD module must be stored for long periods of time:

- (1) Protect the modules from high temperature and humidity.
"Recommended storage conditions" Temperature: 15~25°C, Humidity: 60~70%RH,
No dew condensation to be observed.
- (2) Keep the modules out of direct sunlight or direct exposure to ultraviolet rays.
- (3) Protect the modules from excessive external forces.

3) 液晶表示モジュールを単体で長期保管しなければならない場合について

- (1) 高温、高湿の場所で保管しないで下さい。
<推奨保管条件> 温度: 15~25°C, 湿度: 60~70%RH, 結露の発生なきこと。
- (2) 直射日光、あるいは紫外線が直接当たらないようにして下さい。
- (3) 外部から余計な力が加わらないようにして下さい。

4) Use the module with a power supply that is equipped with an overcurrent protector circuit, since the module is not provided with this protective feature.

- 4) 液晶表示モジュールには、過電流保護回路が入っておりませんので、万一の場合に備え、過電流保護回路内蔵の電源をご使用下さい。

- 5) Do not ingest the LCD fluid itself should it leak out of a damaged LCD module.
Should hands or clothing come in contact with LCD fluid, wash immediately with soap.
- 5) 液晶表示モジュールが破損し、液晶（液体状）がもれ出してきた場合、口に入れないようにして下さい。
液晶が手足や衣服などに付着した場合には、直ちに石けんで洗い流して下さい。
- 6) Conductivity is not guaranteed for models that use metal holders where solder connections between the metal holder and the PCB are not used. Please contact us to discuss appropriate ways to assure conductivity.
- 6) メタルホルダーを使用する機種において、メタルホルダーと基板を半田付けしていない仕様の場合は、導通を保証しません。確実な導通を希望される場合は、別途ご相談下さい。
- 7) For models which use CFL:
- (1) High voltage of 1000V or greater is applied to the CFL cable connector area.
Care should be taken not to touch connection areas to avoid burns.
- (2) Protect CFL cables from rubbing against the unit and thus causing the wire jacket to become worn.
- (3) The use of CFLs for extended periods of time at low temperatures will significantly shorten their service life.
- (4) Lighting may be delayed when CFL is kept in dark or cold place.
If the CFL does not light, turn on the CFL again.
- 7) CFLを使用する機種について
- (1) CFLケーブルのコネクタ部には、1000V以上の高電圧が印加されています。
不用意に接触すると火傷の原因となりますので、取り扱いにご注意下さい。
- (2) CFLケーブルが、筐体に接触し被覆が磨耗しないようにご注意下さい。
- (3) CFLは、低温で連続使用した場合、常温の寿命に対して著しく短くなります。
- (4) 低温及び暗所に保管されている場合、点灯までに時間がかかることが有ります。
- 8) For models which use touch panels:
- (1) Do not stack up modules since they can be damaged by components on neighboring modules.
- (2) Do not place heavy objects on top of the product. This could cause glass breakage.
- 8) タッチパネルを使用する機種について
- (1) 重ね置きをしないで下さい。エッジで製品を傷つけることがあります。
- (2) 上に重量物を置かないで下さい。
- 9) For models which use COG, TCP, or COF:
- (1) The mechanical strength of the product is low since the IC chip faces out unprotected from the rear. Be sure to protect the rear of the IC chip from external forces.
- (2) Given the fact that the rear of the IC chip is left exposed, in order to protect the unit from electrical damage, avoid installation configurations in which the rear of the IC chip runs the risk of making any electrical contact.
- 9) COG, TCP, COFを使用する機種について
- (1) ICチップ裏面がそのまま露出している為、機械的強度が低くなっています。
取扱いに際しては、ICチップ裏面に強い外力が加わらないよう十分注意して下さい。
- (2) ICチップ裏面がそのまま露出している為、電氣的破壊防止としてICチップ裏面に電氣的接触が発生するような実装構造は避けて下さい。また、光による誤動作を防止し、電氣的特性を確保するため、光が当たらない実装構造として下さい。

10) Models which use flexible cable, heat seal, or TCP:

- (1) In order to maintain reliability, do not touch or hold by the connector area.
- (2) Avoid any bending, pulling, or other excessive force, which can result in broken connections.

10) フレキ、ヒートシール、TCPを使用する機種について

- (1) 信頼性確保の為、接続部は持たないで下さい。
- (2) 断線の可能性がある為、無理な折り曲げや、引っ張り等の強い力を加えないで下さい。

11) In case of buffer material such as cushion / gasket is assembled into LCD module, it may have an adverse effect on connecting parts (LCD panel-TCP / HEAT SEAL / FPC / etc., PCB-TCP / HEAT SEAL / FPC etc., TCP-HEAT SEAL, TCP-FPC, HEAT SEAL-FPC, etc.) depending on its materials.

Please check and evaluate these materials carefully before use.

- 11) 液晶モジュールにクッション材等を装着する場合、クッション材等の材質により、液晶モジュール接続部（LCDパネルとTCP/ヒートシール/FPC等、PCBとTCP/ヒートシール/FPC等、TCP/ヒートシール/FPC等の相互の接続部）に悪影響を及ぼす可能性がありますので、事前に十分な評価をして下さい。

12) In case of acrylic plate is attached to front side of LCD panel, cloudiness (very small cracks) can occur on acrylic plate, being influenced by some components generated from polarizer film.

Please check and evaluate those acrylic materials carefully before use.

- 12) 液晶パネルの前面にアクリル板を設置する場合、アクリルの材質により、偏光板から発生する成分の影響でアクリル板に白濁（微細なクラック）が発生する可能性がありますので、事前に十分な評価を実施して下さい。

13) Flickering due to optical interference may occur by combination of a) LCD driving frame frequency decided by either internal oscillator in driver IC or external clock input by the customer and b) lighting frequency of either backlight or other light sources.

Please evaluate enough at the environment of actual use, and decide the driving condition that does not cause flickering.

- 13) ドライバIC内蔵発振回路あるいは外部入力クロックによって決定された液晶駆動フレーム周波数の値によっては、バックライト、その他の光源の点灯周波数あるいは調光周波数との光学的な干渉によるフリッカーが発生する可能性がありますので、実使用環境における十分な評価を行い、フリッカーの発生しない条件にてご使用下さい。

14) Please be advised that do not apply Direct Current (DC) voltage to the LCD.

If DC voltage is applied to the LCD, then it may cause poor display quality.

- 14) 液晶表示素子に直流電圧（DC）が印加されないように注意願います。
印加された場合、表示不良の原因となります。

15. Warranty (保証条件)

This product has been manufactured to your company's specifications as a part for use in your company's general electronic products. It is guaranteed to perform according to delivery specifications. For any other use apart from general electronic equipment, we cannot take responsibility if the product is used in medical devices, nuclear power control equipment, aerospace equipment, fire and security systems, or any other applications in which there is a direct risk to human life and where extremely high levels of reliability are required.

If the product is to be used in any of the above applications, we will need to enter into a separate product liability agreement.

弊社製品は、御社の一般的電子機器製品用の部品として、御社設計ご指示に基づき製造されたものであり、弊社納入仕様書保証条件に準拠するものです。万一、弊社製品が一般電子機器以外の直接人命に関わる医療機器、原子力制御機器、航空宇宙機器、防災防犯装置等の極めて高い信頼性を要求される用途に使用される場合、弊社としては一切の責任を負いません。尚、かかる用途に使用される場合、製造物責任に関する契約を、別途締結して頂くようお願い申し上げます。

- 1) **We cannot accept responsibility for any defect, which may arise from additional manufacturing of the product (including disassembly and reassembly), after product delivery.**
 - 1) 納入後に行われた追加工（分解・再組立を含む）における不具合につきましては、その責任を負いません。
- 2) **We cannot accept responsibility for any defect, which may arise after the application of strong external force to the product.**
 - 2) 外力が加わったことにより発生する不具合につきましては、その責任を負いません。
- 3) **We cannot accept responsibility for any defect, which may arise due to the application of static electricity after the product has passed your company's acceptance inspection procedures.**
 - 3) 弊社製品検査にて合格し、出荷された後、静電気等が印加されて発生する不具合につきましては、その責任を負いません。
- 4) **When the product is in CFL models, CFL service life and brightness will vary according to the performance of the inverter used, leaks, etc. We cannot accept responsibility for product performance, reliability, or defect, which may arise.**
 - 4) CFLを使用する機種において、CFLの寿命や輝度は、使用するインバーターの性能やリーク等で変化します。製品状態での性能、信頼性及び不具合につきましては、その責任を負いません。
- 5) **We cannot accept responsibility for intellectual property of a third party, which may arise through the application of our product to your assembly with exception to those issues relating directly to the structure or method of manufacturing of our product.**
 - 5) 弊社製品を使用したことにより起因する工業所有権の諸問題については、弊社製品の構造や製法に直接関わるもの以外につきましては、その責任を負いません。
- 6) **Optrex will not be held responsible for any quality guarantee issue for defect products judged as Optrex-origin in 2 (two) years from Optrex production or 1(one) year from Optrex Group delivery which ever is shorter.**
 - 6) 弊社に起因すると判定された不具合品の無償保証期間につきましては、弊社製造後より2年、若しくは弊社出荷後、又は取り扱い店出荷後1年のどちらか短い期限とさせていただきます。

Our company network supports you worldwide with offices in Germany, Austria, Switzerland, the UK and the USA. For more information please contact:

Headquarters

Germany



FORTEC Elektronik AG

Lechwiesenstr. 9
86899 Landsberg am Lech

Phone: +49 8191 91172-0
E-Mail: sales@forteca.de
Internet: www.forteca.de

Fortec Group Members

Austria



FORTEC Elektronik AG

Office Vienna
Nuschinggasse 12
1230 Wien

Phone: +43 1 8673492-0
E-Mail: office@fortec.at
Internet: www.fortec.at

Germany



Distec GmbH

Augsburger Str. 2b
82110 Germering

Phone: +49 89 894363-0
E-Mail: info@distec.de
Internet: www.distec.de

Switzerland



ALTRAC AG

Bahnhofstraße 3
5436 Würenlos

Phone: +41 44 7446111
E-Mail: info@altrac.ch
Internet: www.altrac.ch

United Kingdom



Display Technology Ltd.

Osprey House, 1 Osprey Court
Hichingbrooke Business Park
Huntingdon, Cambridgeshire, PE29 6FN

Phone: +44 1480 411600
E-Mail: info@displaytechnology.co.uk
Internet: www.displaytechnology.co.uk

USA



Apollo Display Technologies, Corp.

87 Raynor Avenue,
Unit 1 Ronkonkoma,
NY 11779

Phone: +1 631 5804360
E-Mail: info@apolloDisplays.com
Internet: www.apolloDisplays.com