



OUR GLOBAL
COMPETENCE
CENTRES

 APOLLO DISPLAY
TECHNOLOGIES



 DISTEC



 DISPLAY
TECHNOLOGY



Datasheet

Tianma

TM%\$%8 HG3&0\$

TI-€F-00H



MODEL NO : TM101JDHG32
MODEL VERSION: 00
SPEC VERSION : V1.0
ISSUED DATE: 2016-07-25

- Preliminary Specification
 Final Product Specification

Customer : _____

Approved by	Notes

TIANMA Confirmed :

Prepared by	Checked by	Approved by
Jun Li 2016-07-25		

This technical specification is subjected to change without notice



Table of Contents

Table of Contents	2
Record of Revision.....	3
1 General Specifications.....	4
2 Input/Output Terminals	5
3 Absolute Maximum Ratings.....	6
4 Electrical Characteristics	7
5 Timing Chart.....	10
6 Optical Characteristics	13
7 Environmental / Reliability Test.....	17
8 Mechanical Drawing	18
9 Packing Drawing	19
10 Precautions For Use of LCD Modules	22



1 General Specifications

Feature		Spec
Display Spec.	Size	10.1 inch
	Resolution	1280(RGB) x 800
	Technology Type	SFT
	Pixel Configuration	R.G.B. Vertical Stripe
	Pixel Pitch (mm)	0.1695x0.1695
	Display Mode	TM with Normally Black
	Surface Treatment(Up Polarizer)	HC
Viewing Direction	All direction	
Mechanical Characteristics	LCM (W x H x D) (mm)	229.8x149.0x9.11
	Active Area(mm)	216.96x135.60
	With /Without TSP	Without TSP
	Matching Connection Type	CN1:JAE FI-SE20P-HFE-E3000 CN2:JAE FI-S6P-HFE-E1500
	Weight (g)	TBD
Electrical Characteristics	TFT Interface	LVDS
	Color Depth	262K/16.7M
	LCD Driver IC	ST5084*1,ST5821*3

Note 1: Viewing direction for best image quality is different from TFT definition, there is a 180 degree shift.

Note 2 : Requirements on Environmental Protection: Q/S0002

Note 3 : LCM weight tolerance : +/- 5%



2 Input/Output Terminals

2.1 TFT LCD Panel

Connector type:

CN1:JAE FI-SE20P-HFE-E3000

CN2:JAE FI-S6P-HFE-E1500

No	Symbol	I/O	Description	Comment
CN1				
1	IND3+	I	Positive LVDS Differential data input(3)	
2	IND3-	I	Negative LVDS Differential data input(3)	
3	NC	-	No Connection	
4	SEL6/8	I	6bit/8bit mode select H:6-bit mode L:8-bit mode	
5	VSS	P	Power Ground	
6	PINC	I	Positive LVDS Differential clock input	
7	NINC-	I	Negative LVDS Differential clock input	
8	VSS	P	Power Ground	
9	IND2+	I	Positive LVDS Differential data input(2)	
10	IND2-	I	Negative LVDS Differential data input(2)	
11	VSS	P	Power Ground	
12	IND1+	I	Positive LVDS Differential data input(1)	
13	IND1-	I	Negative LVDS Differential data input(1)	
14	VSS	P	Power Ground	
15	IND0+	I	Positive LVDS Differential data input(0)	
16	IND0-	I	Negative LVDS Differential data input(0)	
17	VSS	P	Power Ground	
18	NC	-	No Connection	
19	VDD	P	Power Supply	
20	VDD	P	Power Supply	
CN2				
1	VLED	P	Backlight power supply	
2	VLED	P	Backlight power supply	
3	VLSS	P	VLED Ground	
4	VLSS	P	VLED Ground	
5	LED_EN	I	Backlight on/off control	
6	LED_PWM	I	Backlight dimming control	

Note: I/O definition:

I----Input P----Power/Ground



3 Absolute Maximum Ratings

3.1 Driving TFT LCD Panel

GND=0V

Item	Symbol	MIN	MAX	Unit	Remark
Voltage Input	V _{in}	-0.50	5.00	V	Note1
Operating Temperature	T _{op}	-20.0	70.0	°C	
Storage Temperature	T _{st}	-30.0	80.0	□	
Relative Humidity (Note2)	RH	--	≤95	%	T _a ≤40°C
		--	≤85	%	40°C < T _a ≤ 50°C
		--	≤55	%	50°C < T _a ≤ 60°C
		--	≤36	%	60°C < T _a ≤ 70°C
		--	≤24	%	70°C < T _a ≤ 80°C
Absolute Humidity	AH	--	≤70	g/m ³	T _a >70°C

Table 3.1 absolute maximum rating

Note1: Input voltage include Rxin0-/+, Rxin1-/+, Rxin2-/+, Rxin3-/+, RxCLK-/+, SEL6/8,VDD

Note2: T_a means the ambient temperature.

It is necessary to limit the relative humidity to the specified temperature range.
Condensation on the module is not allowed



4 Electrical Characteristics

4.1 Driving TFT LCD Panel

VCC=3.3V,GND=0V, Ta=25℃

Item	Symbol	MIN	TYP	MAX	Unit	Remark
Power supply Voltage	VCC	3.00	3.30	3.60	V	
Power supply ripple	Vp-p	-	-	100	mV	
Power supply current	IDD	-	280	-	mA	
Power consumption	P	-	924	-	mW	Note1
Differential input voltage	Vid	200	-	600	mV	
Differential input common voltage	Vcm	-	1.2	-	V	
Differential input threshold voltage	Low level	VTL	-100	-	-	mV
	High level	VTH	-	-	100	mV
Inrush current	Irush	-	-	1.5	A	

Table 4.1 LCD module electrical characteristics

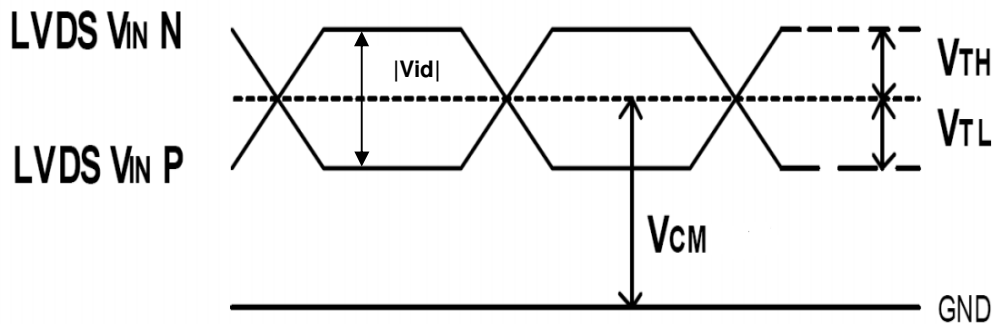

Figure4.1 LVDS DC characteristics

Note1: To test the current dissipation, using the “color bar” testing pattern shown as below:

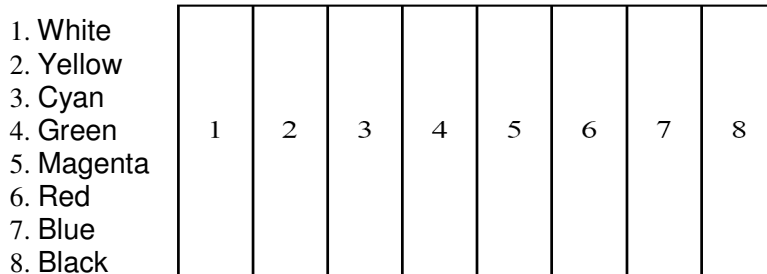

Figure 4.1.2 Current dissipation testing pattern



4.2 Driving Backlight

Ta=25℃

Item	Symbol	Min	Typ	Max	Unit	Remark	
Backlight power supply voltage	VLED	11.5	12	12.5	V		
Backlight power supply current	I_LED	-	750	-	mA		
Backlight power consumption	P_LED	-	9000	-	mW		
Input voltage for VLED_PWM signal	High level	-	2.0	-	5.0	V	
	Low level	-	0	-	0.4	V	
Input voltage for VLED_EN	High level	-	2.0	-	5.0	V	
	Low level	-	0	-	0.4	V	
VLED_PWM frequency	Fpwm	200	-	20k	HZ		
VLED_PWM duty	D	5		100	%	Note1	
Operating Life Time	--		50000		hrs	Note2	

Note 1: According to LED driver IC characteristics, the minimum value of VLED_PWM duty may vary with VLED_PWM frequency, higher the frequency, bigger the duty.

Note 2: Optical performance should be evaluated at Ta=25℃ only.

If LED is driven by high current, high ambient temperature & humidity condition. The life time of LED will be reduced.

Operating life means brightness goes down to 50% of initial brightness.

Typical operating life time is estimated data.

4.2 Block Diagram

The information contained herein is the exclusive property of SHANGHAI TIANMA MICRO-ELECTRONICS Corporation, and shall not be distributed, reproduced, or disclosed in whole or in part without prior written permission of SHANGHAI TIANMA MICRO-ELECTRONICS Corporation.

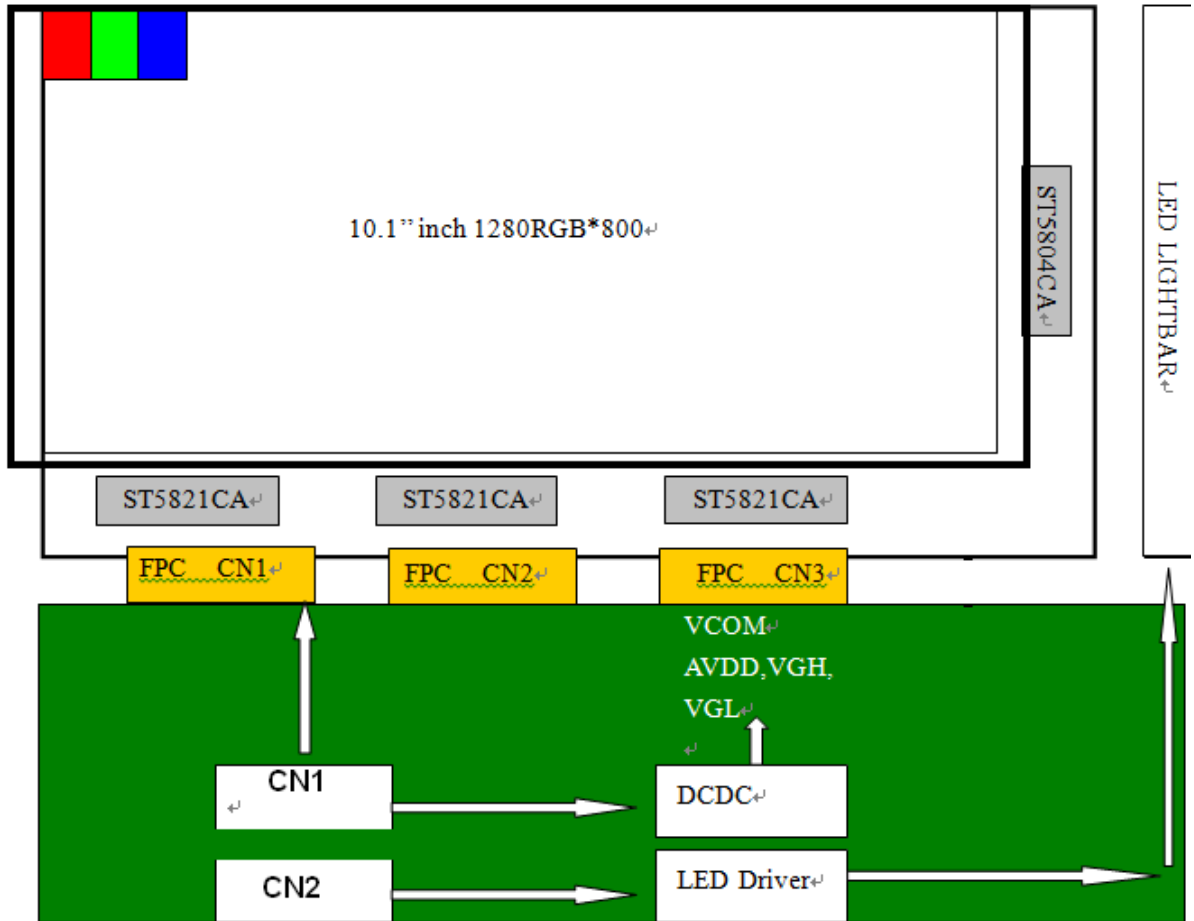



5 Timing Chart

5.1 LVDS signal timing characteristics

VCC=3.3V, GND=0V, Ta=25°C

Parameter	Symbol	Min	Typ	Max	Unit	Remark
CLK frequency	1/t _{clk}	62.6	68.2	78.1	MHz	
Horizontal blanking time	t _{HBT}	20	69	164	t _{clk}	t _{hbp} + t _{HFP}
Horizontal back porch	t _{HBP}	-	5	164- t _{HFP}	t _{clk}	
Horizontal display area	t _{HD}	-	1280	-	t _{clk}	
Horizontal front porch	t _{HFP}	15	64	159	t _{clk}	
Horizontal period	t _H	1300	1349	1444	t _{clk}	
Horizontal pulse width	t _{HPW}	-	1	256	t _{clk}	
Vertical blanking time	t _{VBT}	5	42	101	t _H	t _{VBP} + t _{VFP}
Vertical back porch	t _{VBP}	-	2	101- t _{VFP}	t _H	
Vertical display area	t _{VD}	-	800	-	t _H	
Vertical front porch	t _{VFP}	3	40	99	t _H	
Vertical period	t _V	803	842	901	t _H	
Vertical pulse width	t _{VPW}	-	1	128	t _H	
Frame Rate	F	-	60	-	HZ	

Table 5.1 timing parameter

5.2 Input Clock and Data timing Diagram:

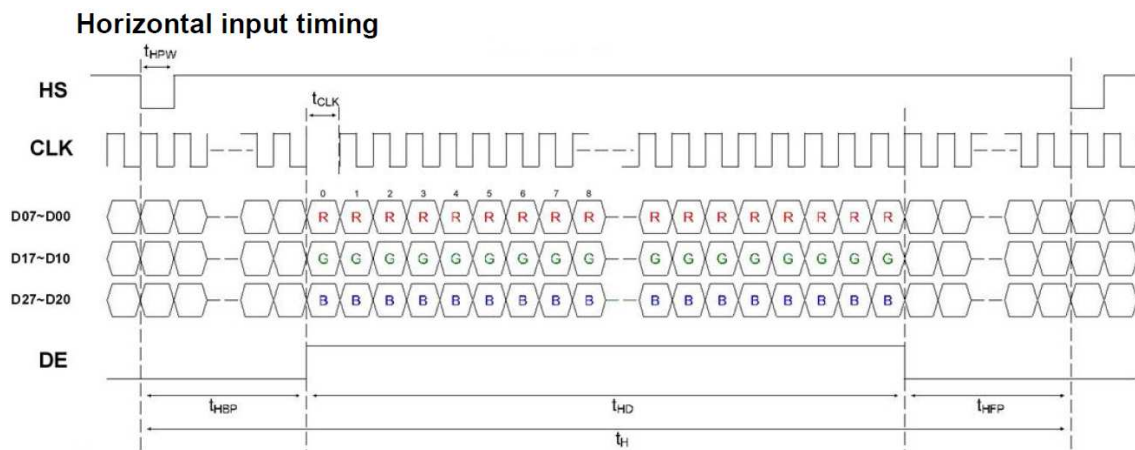

The information contained herein is the exclusive property of SHANGHAI TIANMA MICRO-ELECTRONICS Corporation, and shall not be distributed, reproduced, or disclosed in whole or in part without prior written permission of SHANGHAI TIANMA MICRO-ELECTRONICS Corporation.



Vertical input timing

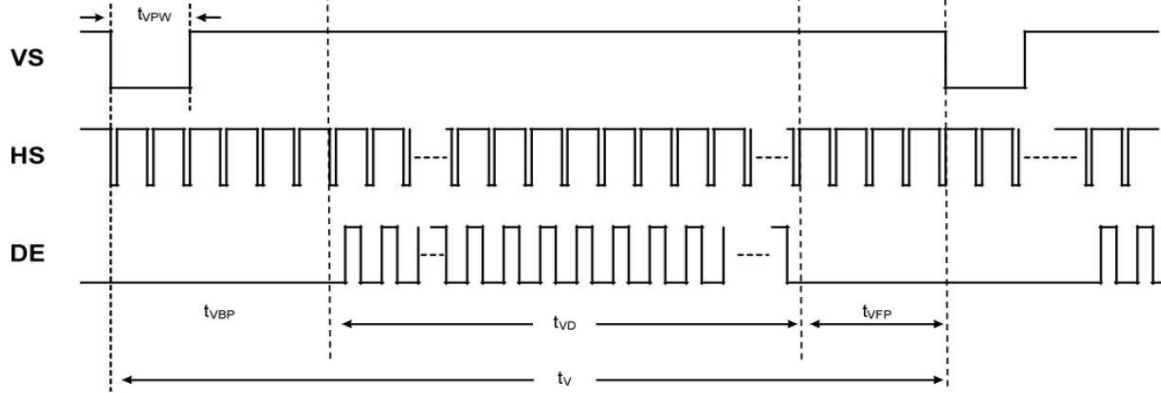
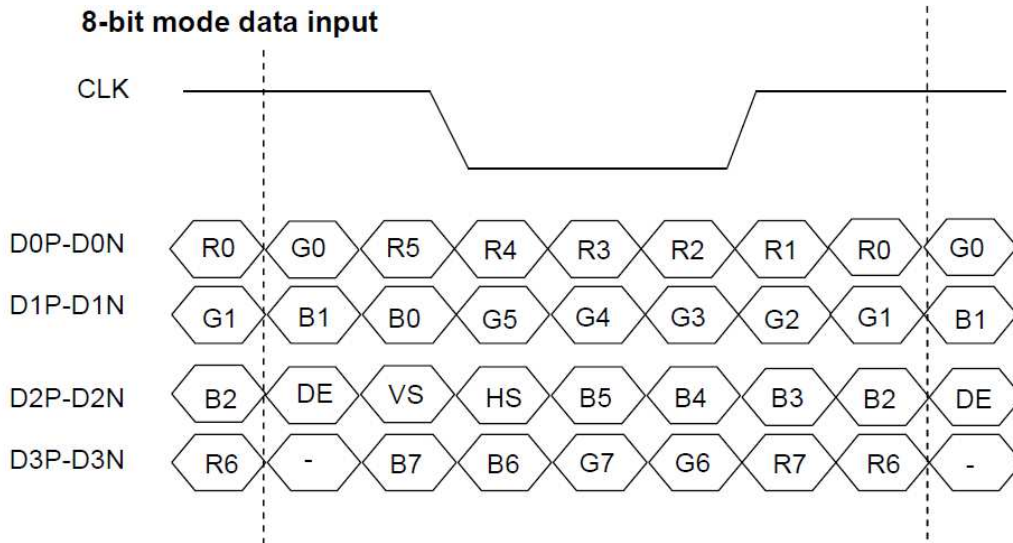

Figure 5.2 Input signal data timing

5.3 LVDS data input format

8-bit mode data input



6-bit mode data input

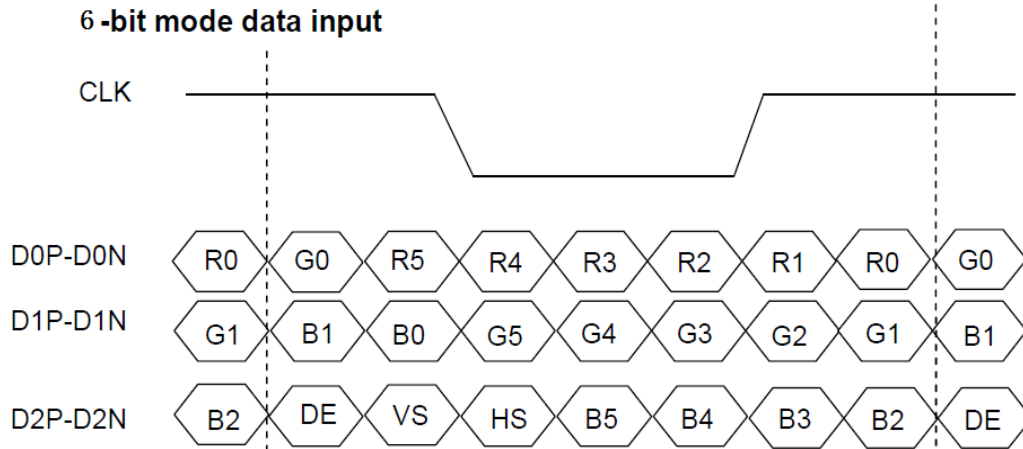



5.4 Power On/Off Sequence

Item	Symbol	Min	Typ	Max	Unit	Remark
VDD on to VDD stable	Tp1	0.5	-	10	ms	
VDD stable to signal on	Tp2	0	-	50	ms	
Signal on to VLED_EN on	Tp3	200	-	-	ms	
PWM on to VLED_EN on	Tp4	0	-	200	ms	
VLED to PWM on	Tp5	10	-	-	ms	
VLED on to VELD stable	Tp6	0.5	-	10	ms	
VDD off time	Tp7	0	-	10	ms	
VDD off to next VDD on	Tp8	500	-	-	ms	
Signal off before VDD off	Tp9	0	-	50	ms	
VLED_EN off before signal off	Tp10	200	-	-	ms	
VLED_EN off before PWM off	Tp11	0	-	200	ms	
PWM off before VLED off	Tp12	10	-	-	ms	

Table 5.1 Power on/off sequence

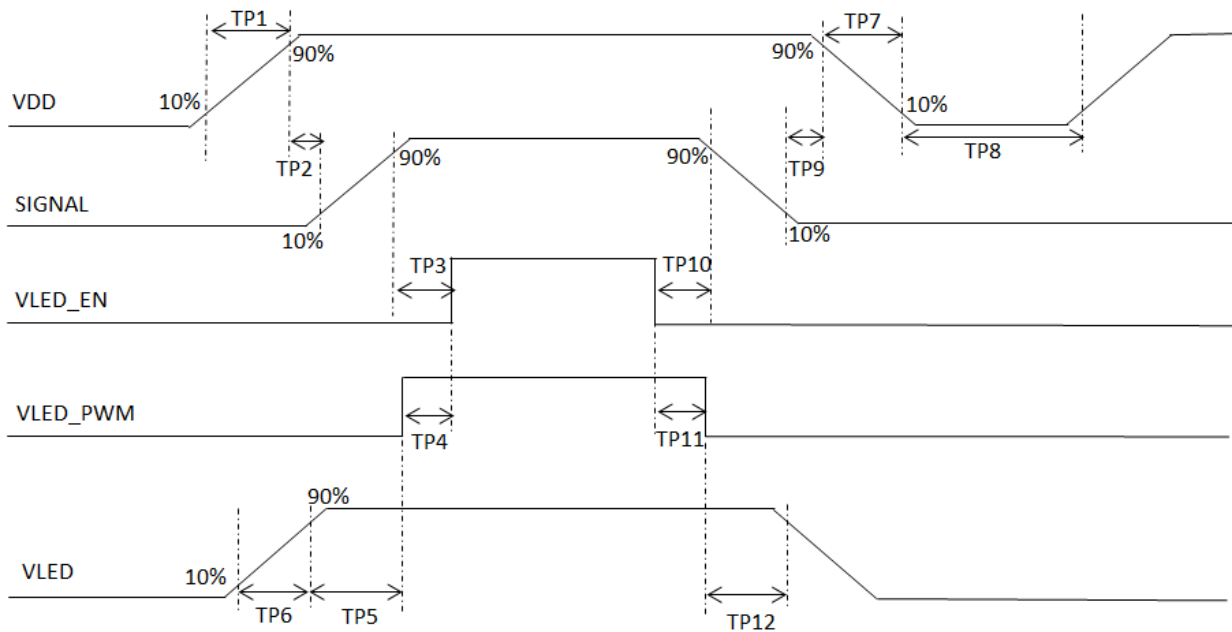

Figure 5.2 Interface power on/off sequence



6 Optical Characteristics

6.1 Optical Specification

Ta=25℃

Item	Symbol	Condition	Min	Typ	Max	Unit	Remark	
View Angles	θT	$CR \geq 10$	75	85	-	Degree	Note 2	
	θB		75	85	-			
	θL		75	85	-			
	θR		75	85	-			
Contrast Ratio	CR	$\theta = 0^\circ$	600	800	-	-	Note1 Note3	
Response Time	T_{ON}	25℃	-	25	40	ms	Note1 Note4	
	T_{OFF}							
Chromaticity	White	Backlight is on	x	0.249	0.299	0.349	-	Note5 Note1
			y	0.270	0.320	0.370		
	Red		x	0.532	0.582	0.632		
			y	0.274	0.324	0.374		
	Green		x	0.300	0.350	0.400		
			y	0.532	0.582	0.632		
	Blue		x	0.104	0.154	0.204		
			y	0.044	0.094	0.144		
Uniformity	U	-	75	80	-	%	Note1 Note6	
NTSC	-	-	45	50	-	%	Note 5	
Luminance	L		-	1000	-	cd/m ²	Note1 Note7	

Test Conditions:

1. The ambient temperature is $25 \pm 2^\circ\text{C}$. humidity is $65 \pm 7\%$
2. The test systems refer to Note 1 and Note 2.



Note 1: Definition of optical measurement system.

The optical characteristics should be measured in dark room. After 5 minutes operation, the optical properties are measured at the center point of the LCD screen. All input terminals LCD panel must be ground when measuring the center area of the panel.

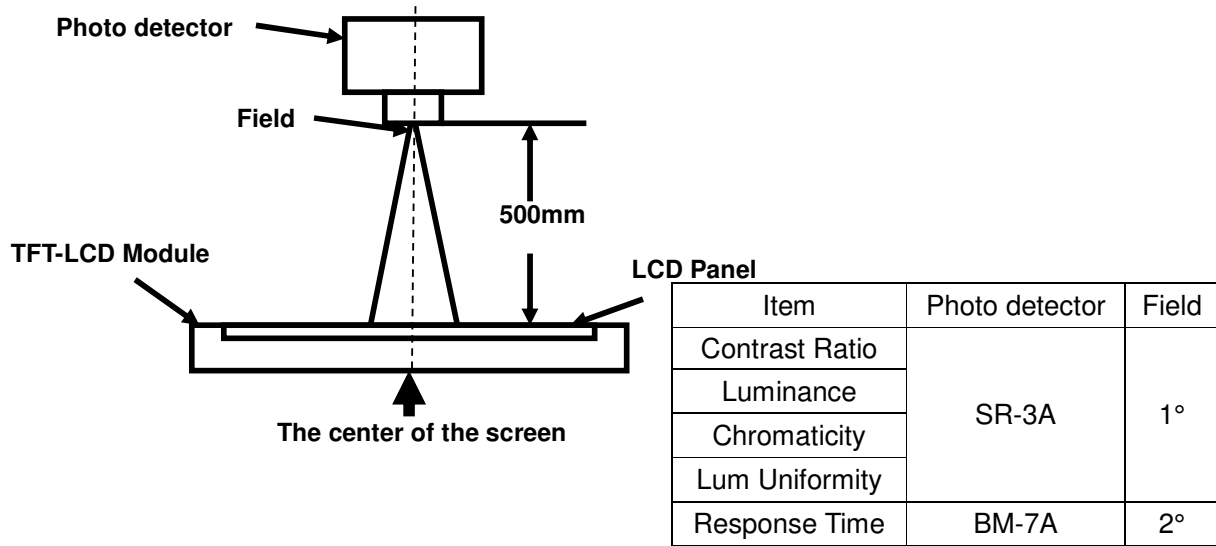

Note 2: Definition of viewing angle range and measurement system.

viewing angle is measured at the center point of the LCD by CONOSCOPE(ergo-80).

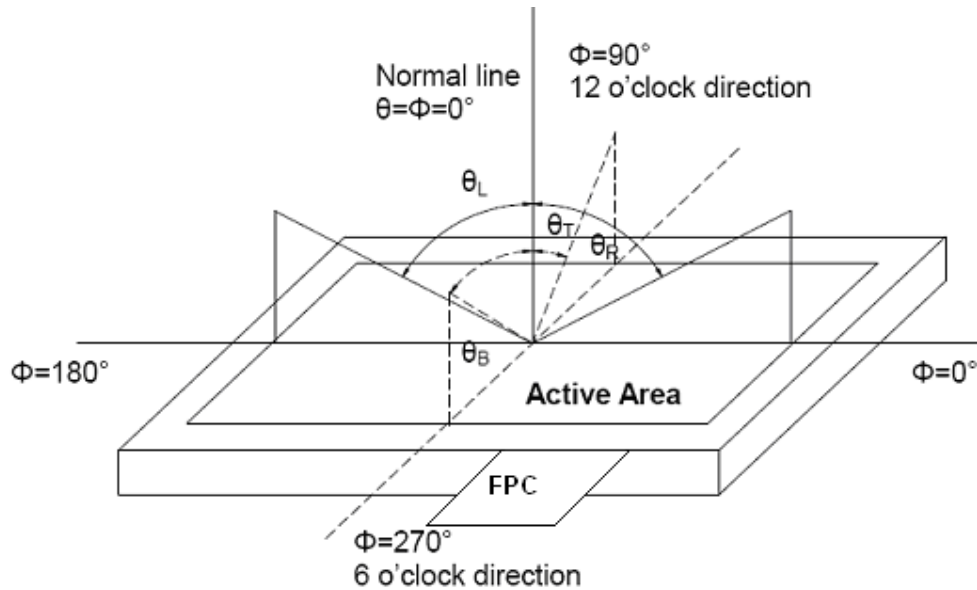

Fig. 1 Definition of viewing angle



Note 3: Definition of contrast ratio

$$\text{Contrast ratio (CR)} = \frac{\text{Luminance measured when LCD is on the "White" state}}{\text{Luminance measured when LCD is on the "Black" state}}$$

“White state “:The state is that the LCD should driven by V_{white} .

“Black state”: The state is that the LCD should driven by V_{black} .

V_{white} : To be determined V_{black} : To be determined.

Note 4: Definition of Response time

The response time is defined as the LCD optical switching time interval between “White” state and “Black” state. Rise time (T_{ON}) is the time between photo detector output intensity changed from 90% to 10%. And fall time (T_{OFF}) is the time between photo detector output intensity changed from 10% to 90%.

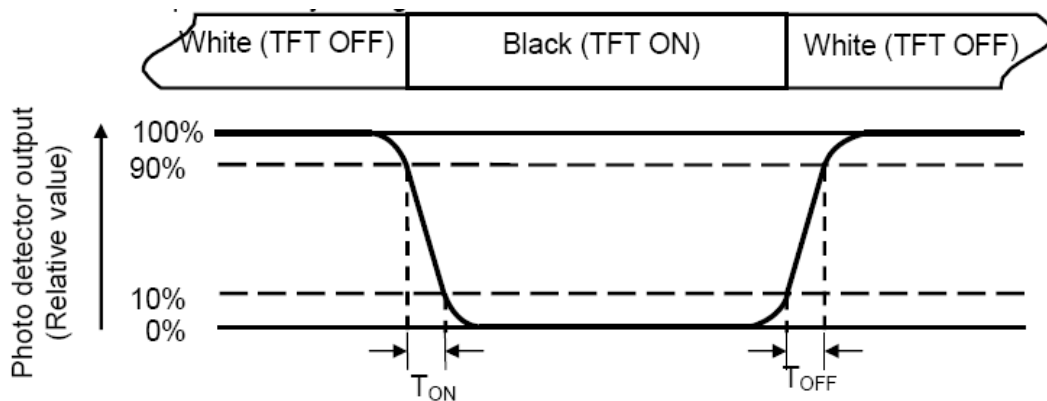

Note 5: Definition of color chromaticity (CIE1931)

Color coordinates measured at center point of LCD.



Note 6: Definition of Luminance Uniformity

Active area is divided into 9 measuring areas (Refer Fig. 2). Every measuring point is placed at the center of each measuring area.

$$\text{Luminance Uniformity}(U) = L_{\min} / L_{\max}$$

L-----Active area length W----- Active area width

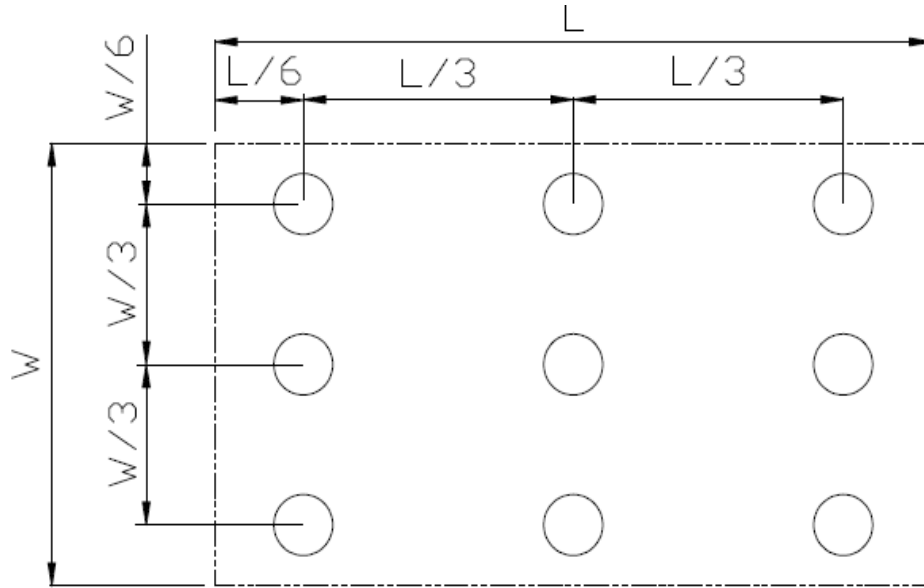

Fig. 2 Definition of uniformity

L_{max}: The measured maximum luminance of all measurement position.

L_{min}: The measured minimum luminance of all measurement position.

Note 7: Definition of Luminance :

Measure the luminance of white state at center point.



7 Environmental / Reliability Test

No	Test Item	Condition	Remark
1	High Temperature Operation	Ts=+70□, 240hrs	(Note1) IEC60068-2-1:2007,GB2423.2-2008
2	Low Temperature Operation	Ta=-20□, 240hrs	IEC60068-2-1:2007 GB2423.1-2008
3	High Temperature Storage (non-operation)	Ta=+80□, 240hrs	IEC60068-2-1:2007 GB2423.2-2008
4	Low Temperature Storage (non-operation)	Ta=-30°C, 240hrs	IEC60068-2-1:2007 GB2423.1-2008
5	High Temperature & High Humidity Operation	Ta = +60□, 90% RH max,240 hours	(Note2) IEC60068-2-78 :2001 GB/T2423.3—2006
6	Thermal Shock (non-operation)	-30□ 30 min~+80□ 30 min, Change time:5min,100cycles	Start with cold temperature, End with high temperature, IEC60068-2-14:1984,GB2423.22-2002
7	Electro Static Discharge (operation)	C=150pF,R=330Ω; Contact:±4Kv, 5times; Air: ± 8KV,5times;	IEC61000-4-2:2001 GB/T17626.2-2006
8	Vibration (non-operation)	Frequency range:10 ~ 55Hz, Stroke:1.5mm Sweep:10Hz ~ 55Hz ~ 10Hz 2hours for each direction of X.Y.Z (6 hours total)	IEC60068-2-6:1982 GB/T2423.10—1995
9	Shock (non-operation)	60G 6ms, ±X,±Y,±Z 3 times for each direction	IEC60068-2-27:1987 GB/T2423.5—1995
10	Package Drop Test	Height:80 cm,1 corner, 3 edges, 6 surfaces	IEC60068-2-32:1990 GB/T2423.8—1995

Note1: Ts is the temperature of panel's surface.

Note2: Ta is the ambient temperature of sample



8 Mechanical Drawing

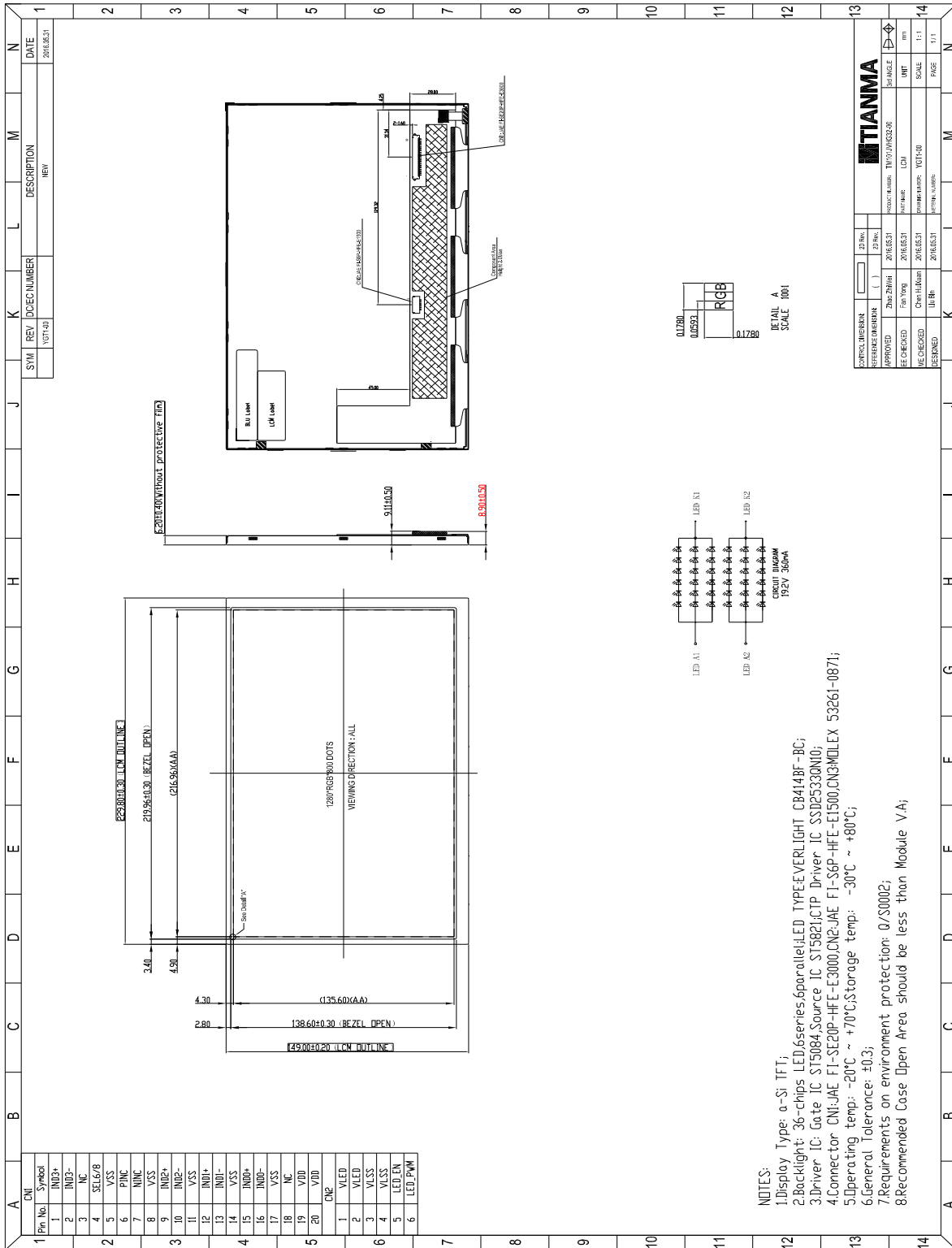

The information contained herein is the exclusive property of SHANGHAI TIANMA MICRO-ELECTRONICS Corporation, and shall not be distributed, reproduced, or disclosed in whole or in part without prior written permission of SHANGHAI TIANMA MICRO-ELECTRONICS Corporation.



9 Packing Drawing

No	Item	Model (Material)	Dimensions(mm)	Unit Weight(Kg)	Quantity	Remark
1	LCM module	TM101JDHG32	231.22x150.60x9.11	TBD	TBD	
2	Dust-Proof Bag	PE	700x545mm	0.046	1	
3	Anti-Static Bag	PE	246x240mm	0.004	1	
4	Partition_1	Corrugated paper	527x348x217mm	1.571	1	
5	Partition_2	Corrugated Paper	505x332x5mm	0.098	2	
6	Corrugated Bar	Corrugated Paper	527x244x7mm	0.057	2	
7	Carton	Corrugated paper	544x365x250mm	1.12	1	
8	Total weight(Kg)					

The packing method is shown as below:

9.1 Put module into anti-static bag

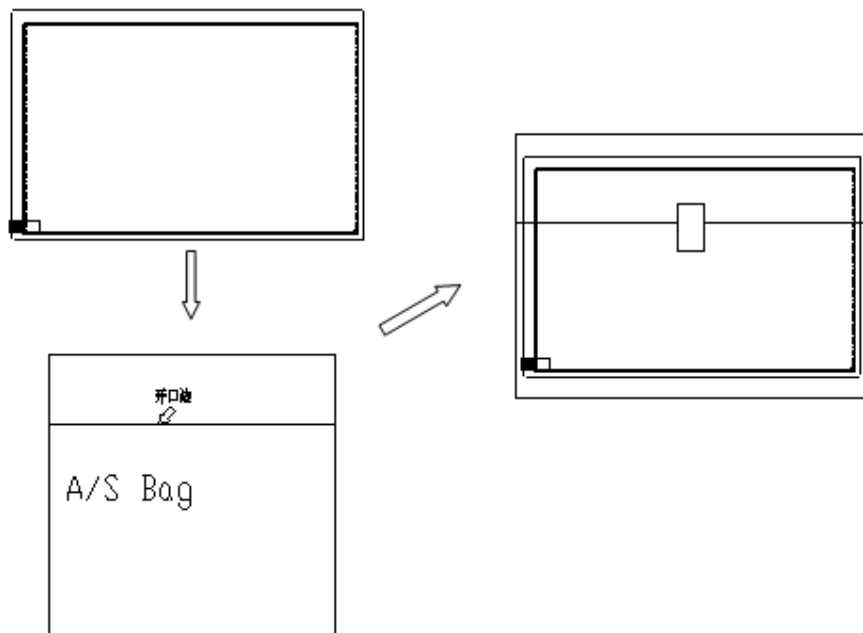



9.2 Dummy packing assembling

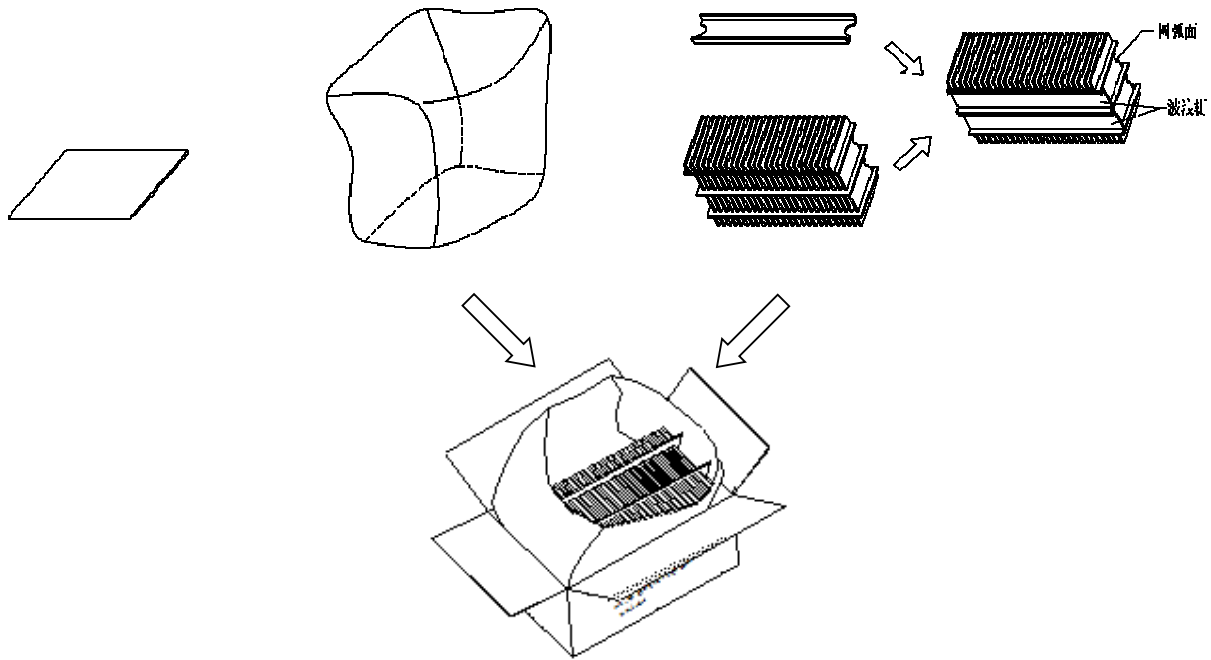

9.3 LCD module assembling

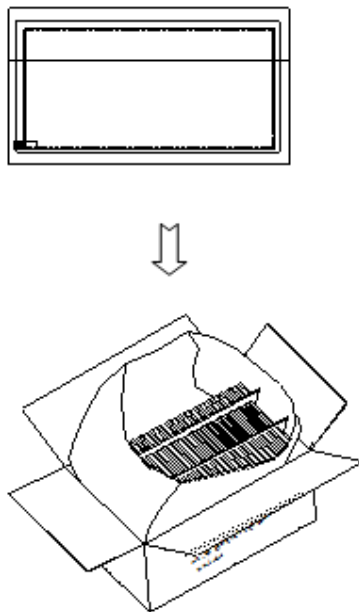



9.4 Box sealent

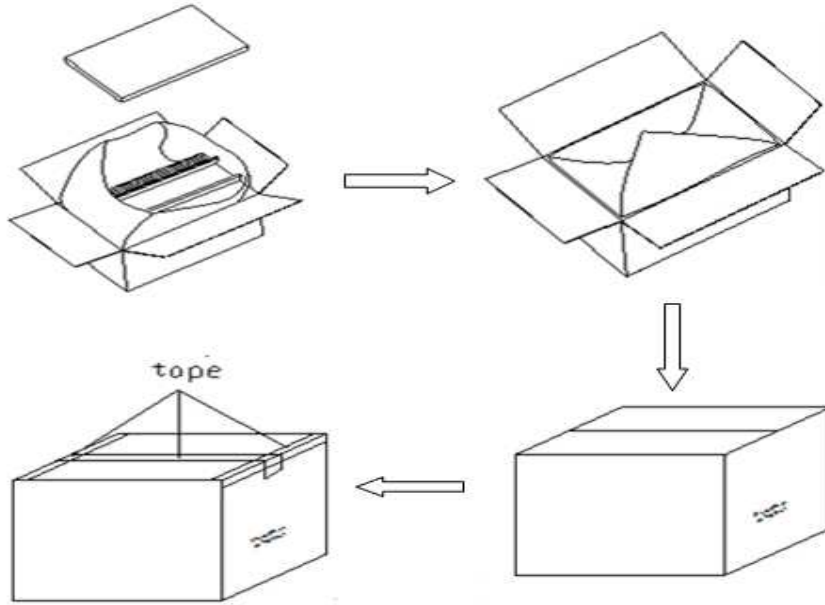

9.5 Stacking method(2x3x5)

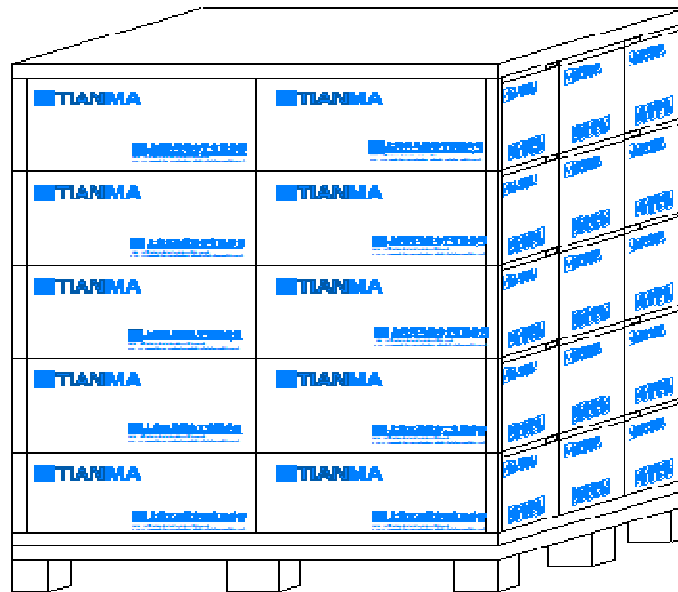



10 Precautions For Use of LCD Modules

10.1 Handling Precautions

- 10.1.1 The display panel is made of glass. Do not subject it to a mechanical shock by dropping it from a high place, etc.
- 10.1.2 If the display panel is damaged and the liquid crystal substance inside it leaks out, be sure not to get any in your mouth, if the substance comes into contact with your skin or clothes, promptly wash it off using soap and water.
- 10.1.3 Do not apply excessive force to the display surface or the adjoining areas since this may cause the color tone to vary.
- 10.1.4 The polarizer covering the display surface of the LCD module is soft and easily scratched. Handle this polarizer carefully.
- 10.1.5 If the display surface is contaminated, breathe on the surface and gently wipe it with a soft dry cloth. If still not completely clear, moisten cloth with one of the following solvents:
 - Isopropyl alcohol
 - Ethyl alcoholSolvents other than those mentioned above may damage the polarizer. Especially, do not use the following:
 - Water
 - Ketone
 - Aromatic solvents
- 10.1.6 Do not attempt to disassemble the LCD Module.
- 10.1.7 If the logic circuit power is off, do not apply the input signals.
- 10.1.8 To prevent destruction of the elements by static electricity, be careful to maintain an optimum work environment.
 - 10.1.8.1 Be sure to ground the body when handling the LCD Modules.
 - 10.1.8.2 Tools required for assembly, such as soldering irons, must be properly ground.
 - 10.1.8.3 To reduce the amount of static electricity generated, do not conduct assembly and other work under dry conditions.
 - 10.1.8.4 The LCD Module is coated with a film to protect the display surface. Be care when peeling off this protective film since static electricity may be generated.

10.2 Storage Precautions

- 10.2.1 When storing the LCD modules, avoid exposure to direct sunlight or to the light of fluorescent lamps.
- 10.2.2 The LCD modules should be stored under the storage temperature range. If the LCD modules will be stored for a long time, the recommend condition is:
Temperature : 0°C ~ 40°C Relatively humidity: ≤80%
- 10.2.3 The LCD modules should be stored in the room without acid, alkali and harmful gas.

10.3 Transportation Precautions

The LCD modules should be no falling and violent shocking during transportation, and also should avoid excessive press, water, damp and sunshine.

Our company network supports you worldwide with offices in Germany, Austria, Switzerland, the UK and the USA. For more information please contact:

Headquarters

Germany



FORTEC Elektronik AG

Lechwiesenstr. 9
86899 Landsberg am Lech

Phone: +49 8191 91172-0
E-Mail: sales@forteca.de
Internet: www.forteca.de

Fortec Group Members

Austria



FORTEC Elektronik AG

Office Vienna
Nuschinggasse 12
1230 Wien

Phone: +43 1 8673492-0
E-Mail: office@fortec.at
Internet: www.fortec.at

Germany



Distec GmbH

Augsburger Str. 2b
82110 Germering

Phone: +49 89 894363-0
E-Mail: info@distec.de
Internet: www.distec.de

Switzerland



ALTRAC AG

Bahnhofstraße 3
5436 Würenlos

Phone: +41 44 7446111
E-Mail: info@altrac.ch
Internet: www.altrac.ch

United Kingdom



Display Technology Ltd.

Osprey House, 1 Osprey Court
Hichingbrooke Business Park
Huntingdon, Cambridgeshire, PE29 6FN

Phone: +44 1480 411600
E-Mail: info@displaytechnology.co.uk
Internet: www.displaytechnology.co.uk

USA



Apollo Display Technologies, Corp.

87 Raynor Avenue,
Unit 1 Ronkonkoma,
NY 11779

Phone: +1 631 5804360
E-Mail: info@apolloDisplays.com
Internet: www.apolloDisplays.com