



OUR GLOBAL
COMPETENCE
CENTRES

 APOLLO DISPLAY
TECHNOLOGIES



 DISTEC



 DISPLAY
TECHNOLOGY



Datasheet

Panasonic

VVX1&F0() J00

PS-01-00G

Panasonic Liquid Crystal Display Co.,Ltd.

Sep.17.2015

TECHNICAL DATA

VVX12F045J00

CONTENTS

No.	Item	Page
-	COVER	1-1/1
-	DESCRIPTION	3-1/1
1	ABSOLUTE MAXIMUM RATINGS	4-1/2~2/2
2	INITIAL OPTICAL CHARACTERISTICS	5-1/2~2/2
3	ELECTRICAL CHARACTERISTICS	6-1/1
4	BLOCK DIAGRAM	7-1/1
5	INTERFACE PIN ASSIGNMENT	8-1/3~3/3
6	INTERFACE TIMING	9-1/4~4/4
7	LABEL FORMAT	10-1/2~2/2
9	PRECAUTION	12-1/3~3/3
10	PACKING	13-1/2~2/2
11	DIMENSIONAL OUTLINE	14-1/2~2/2

DESCRIPTION

The following specifications are applied to the following IPS-Pro-TFT LCD module.

Product Name : VVX12F045J00

Production factory: Kentec Inc.

Country of origin: Taiwan

General Specifications

Display size	: 11.6	(inch)
Effective display area	: (H) 256.896 × (V) 144.504	(mm)
Number of pixels	: (H) 1,920 × (V) 1,080	(pixels)
Pixel pitch	: (H) 0.1338 × (V) 0.1338	(mm)
Pixel density	: 190	(ppi)
Color pixel arrangement	: B+G+R vertical stripe	
Display mode	: Transmissive mode Normally black mode	
Top polarizer type	: Anti-Glare	
Polarizer absorption axis	: Upprer : 0 degree Lower : 90 degree	
Number of colors	: 16,777,216	(colors)
Input signal	: eDP (Ver 1.3) 2Lane	
Backlight	: 36 pieces of LED (LED : Light-emitting diode)	
External dimensions	: Typ. (H)269.2 × (V)158.8 ×(T)2.95	(mm)
Weight	: Typ. 178	(g)

1. ABSOLUTE MAXIMUM RATINGS

1.1 Environmental Absolute Maximum Ratings

ITEM	Operating		Storage		UNIT	NOTE
	Min.	Max.	Min.	Max.		
Temperature	0	50	-20	60	°C	1),3)
Humidity	2)		2)		%RH	1),4)
Vibration	-	-	-	5)	Grms	6)
Shock	-	-	-	2058 (210G)	m/s ²	7),8)
Corrosive Gas	Not Acceptable		Not Acceptable		-	
Illumination at LCD Surface	-	50,000	-	50,000	1x	

Note 1) Temperature and Humidity should be applied to the glass surface of a IPS-Pro TFT LCD module, not to the system installed with a module.

- 2) $T_a \leq 40\text{ }^\circ\text{C}$ ······ Relative humidity should be less than 85 %RH max. Dew is prohibited.
 $T_a > 40\text{ }^\circ\text{C}$ ······ Relative humidity should be lower than the moisture of the 85 %RH at 40 °C.

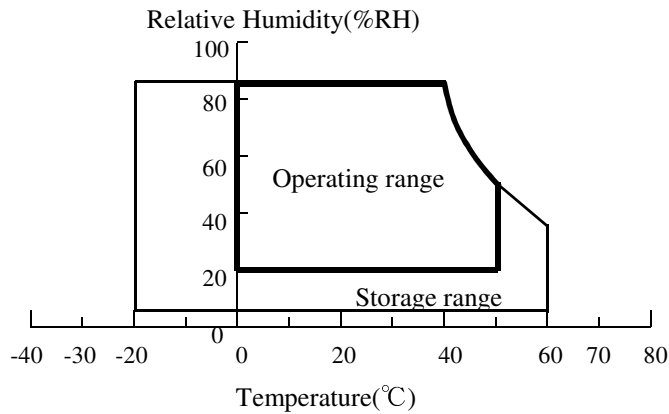

- 3) The temperature of LCD front surface would be 65 °C in operating, it may affect the optical characteristics however it does not damage the function of the module.
- 4) The humidity of LCD front surface would be less than 20%RH in storage, it may affect the optical characteristics, however it does not damage the function of the module.
- 5) Random 2.3Grms: 5-50Hz 0.11G²/Hz, 50-100Hz -36dB/oct
- 6) Direction : ±X, ±Y, ±Z (One time each direction) 20min, total 60min.
- 7) Direction : ±X, ±Y, ±Z (One time each direction)
- 8) Pulse width of the shock is 2 ms.

1. 2 Electrical Absolute Maximum Ratings

(1)TFT-LCD module

VSS = 0 V

ITEM	SYMBOL	Min.	Max.	UNIT	NOTE
Power Supply Voltage	V _{DD}	-0.3	5	V	
Input Voltage for LED driver	V _{LED}	-0.3	16	V	
Input Voltage for logic 1	VI_1	-0.3	2	V	1)
Input Voltage for logic 2	VI_2	-0.3	6	V	2)

Note

1) eDP signal (Lane0_P/N, Lane1_P/N, AUX_CH_P/N)

2) LED_PWM, LED_EN

2. INITIAL OPTICAL CHARACTERISTICS

The following optical characteristics are measured under stable conditions. It takes about 10 minutes to reach stable conditions. The measuring point is the center of display area unless otherwise noted.

The optical characteristics should be measured in a dark room or equivalent state.

Measuring equipment : CS-1000A, or equivalent

Ambient Temperature =25 °C, VDD=3.3 V, VLED=13V, fV=60 Hz ,

LED current = 20.0mA/string (On-duty=100%)

ITEM	SYMBOL	CONDITION	Min.	Typ.	Max.	UNIT	NOTE	
Contrast ratio	CR	$\theta = 0^\circ$ 1)	600	1000	-	-	2)	
Response time	Tr + Tf		-	26	35	ms	3)	
Brightness of white	Bwh		210	280	-	cd/m ²	4)	
Brightness uniformity	Buni		65	-	-	%	4)	
Color chromaticity (CIE)	Red		x	0.620	0.650	0.680	-	【Gray scale =255】
			y	0.295	0.325	0.355		
	Green		x	0.295	0.325	0.355		
			y	0.582	0.612	0.642		
	Blue		x	0.115	0.145	0.175		
			y	0.015	0.045	0.075		
White	x	0.283	0.313	0.343				
	y	0.299	0.329	0.359				
Contrast ratio at 85 °	CR85	$\varphi=0^\circ, 90^\circ, 180^\circ, 270^\circ$ 5)	10	-	-	-	Estimated value	
NTSC	-	$\theta=0^\circ$	-	72	-	%	-	
Gamma	-	$\theta=0^\circ$	-	2.2	-	-	-	
Image sticking	-	Checker pattern	Not recognized			-	6)	
Cross talk	-	$\theta=0^\circ$	Not recognized			-	7)	

Note 1) Definition of viewing angle

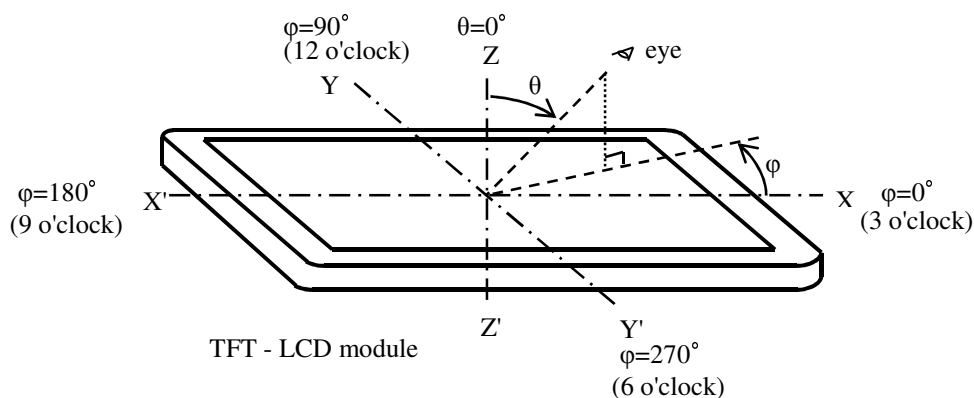

Note 2) Definition of contrast ratio (CR)

$$CR = \frac{B_{WH}}{B_{BL}}$$

B_{WH} : Brightness at white raster-state

B_{BL} : Brightness at black raster-state

3) Definition of response time
Displaying data signal

t_r = Start-up time

t_f = Falling time

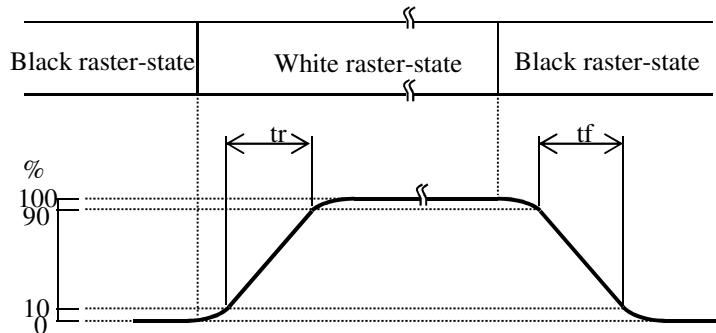

4) Definition of response time

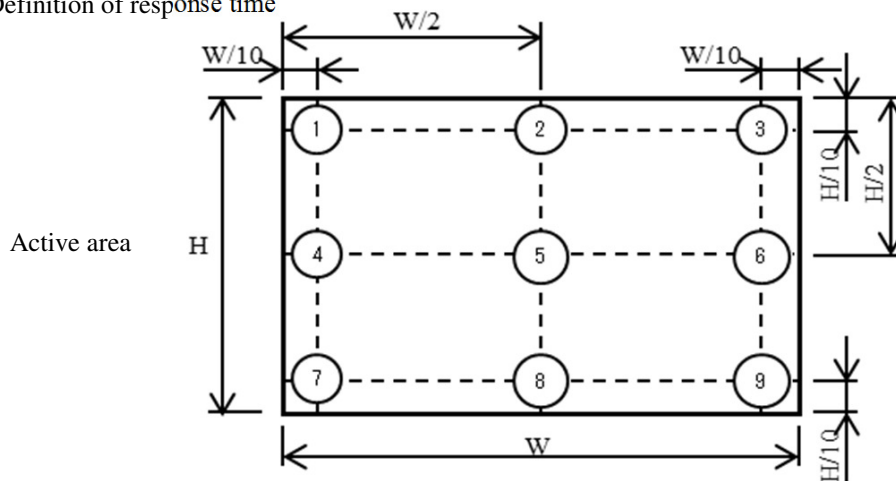

①-⑨ : Measurement points

Brightness : point5

Buni (9 points) : $\text{Min}(\text{①-⑨}) / \text{Max}(\text{①-⑨}) \times 100\%$

5) Contrast ratio at 85 °

Evaluation conditions are on horizontal & vertical axis

6) Aging :

4h aging with checker pattern at room temperature.

Check :

After aging, turn on gray raster (127/255 level) pattern

It must not recognize within 5 seconds when hold

6% ND filter to the display side.

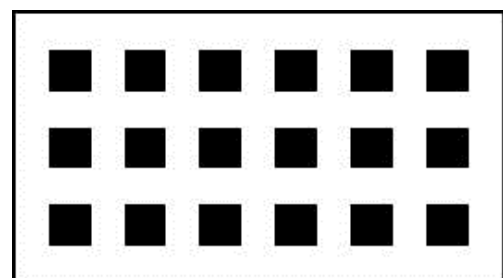

Display pattern for image sticking

7) It must not recognize within 5 seconds when hold 6% ND filter to the display side.

3. ELECTRICAL CHARACTERISTICS

3.1 TFT-LCD module

Ta = 25°C, V_{SS} = 0 V

ITEM	SYMBOL	Min.	Typ.	Max.	UNIT	NOTE
Power supply voltage	V _{DD}	3.0	3.3	3.6	V	
Power supply current	I _{DD}	-	210	710	mA	1)
Ripple voltage of power supply	V _{DDR}	-	-	150	mV	
Input voltage for LED driver	V _{LED}	11.4	-	13.65	V	
Logic signals input voltage	High	VIH1	1.6	-	V	LED_PWM LED_EN 2)
	Low	VIL1	-	0.7		
Logic signals output voltage	High	VOH1	2.0	-	V	HPD
	Low	VOL1	-	0.8		

Note 1) Typ: fV=60.0Hz, V_{DD}=3.3V, and display pattern is white raster.

Max: fV=60.0Hz, V_{DD}=3.0V, display pattern is horizontal stripe. (white and black)

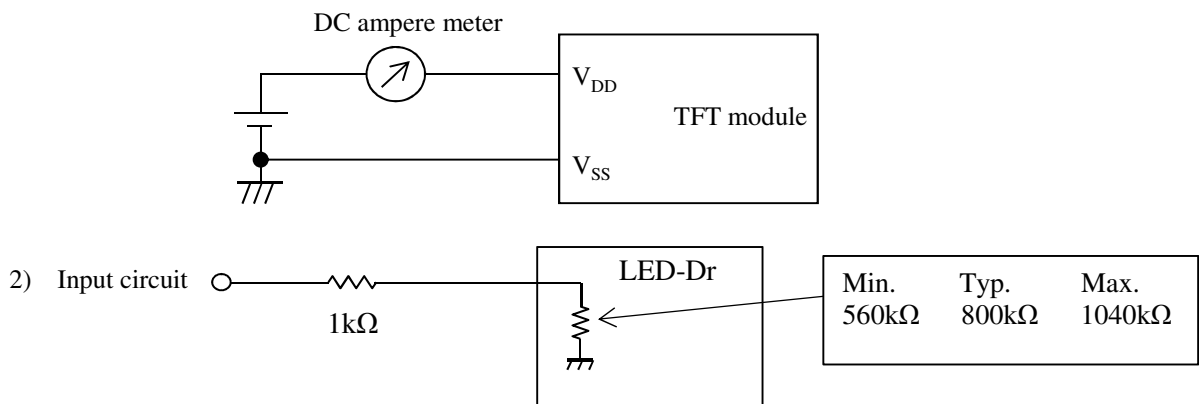

3.2 Backlight unit

ITEM	SYMBOL	Min.	Typ.	Max.	UNIT	NOTE
Power Consumption	P _{bl}	-	2.52	3.1	W	1)
PWM	Duty	PD	1	100	%	4)
	Frequency	PF	100	5k	Hz	
LED Life time	-	15,000	-	-	h	2), 3)

One Backlight Unit : 1 LED Array

One LED Array : 6 LED String

One LED String : 6 LED package

Note 1) PWM on-duty=100%

2) Life time of a LED is defined as follows. The life is determined as the time at which brightness of the LED is 50% compared to that of initial value at that typical forward current on condition of continuous operating at 25 ± 2°C

3) LED current value is I_f= 20mA

4) The minimum period of BL_EN=L is 100ms.

(There is no limitation for the minimum period of BL_EN=L when PWM duty is 99% or less..)

4. BLOCK DIAGRAM

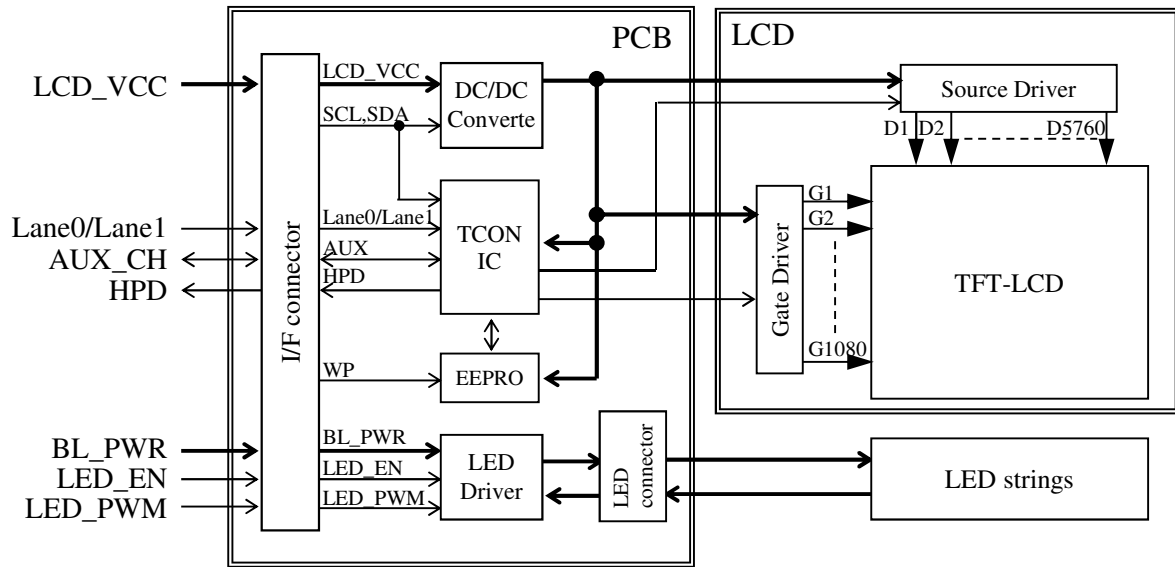

5. INTERFACE PIN ASSIGNMENT

5.1 Pin alignment

Connector's Part Number : HD2S030HA1 (Maker : JAE)

PIN No.	SYMBOL	I/O	DESCRIPTION	Note	PIN No.	SYMBOL	I/O	DESCRIPTION	Note
1	WP	I	EEPROM Write Protect	5)	16	LCD_GND	-	GND (0V)	2)
2	H_GND	-	High Speed Ground (0V)	2)	17	HPD	O	Hot plug detection	
3	Lane1_N	I	Complement Signal Link Lane 1		18	BL_GND	-	GND (0V)	2)
4	Lane1_P	I	True Signal Link Lane 1		19	BL_GND			
5	H_GND	-	High Speed Ground (0V)	2)	20	BL_GND			
6	Lane0_N	I	Complement Signal Link Lane 0		21	BL_GND			
7	Lane0_P	I	True Signal Link Lane 0		22	LED_EN	I	Enable signal for Backlight	4)
8	H_GND	-	High Speed Ground (0V)	2)	23	LED_PWM	I	Brightness control of Backlight	4)
9	AUX_CH_P	IO	True Signal Aux Channel		24	SDA	IO	I2C-bus Data	5)
10	AUX_CH_N	IO	Complement Signal Aux Channel		25	SCL	I	I2C-bus Clock	5)
11	H_GND	-	High Speed Ground (0V)	2)	26	BL_PWR	P	Power supply for Backlight	3)
12	LCD_VCC	P	Power supply for LCD	1)	27	BL_PWR			
13	LCD_VCC				28	BL_PWR			
14	BIST	I	Keep open or connect to GND		29	BL_PWR			
15	LCD_GND	-	GND (0V)	2)	30	GND	-	GND (0V)	2)

- Notes
- 1) All pins should be connected to the power supply for LCD on the customer's product.
 - 2) All pins should be connected to GND(0V) on the customer's product.
 - 3) All pins should be connected to the power supply for Backlight on the customer's product.
 - 4) H=on (active), L=off (non-active)
 - 5) Keep open. (It is no problem because this pin has an internal pull-up.)

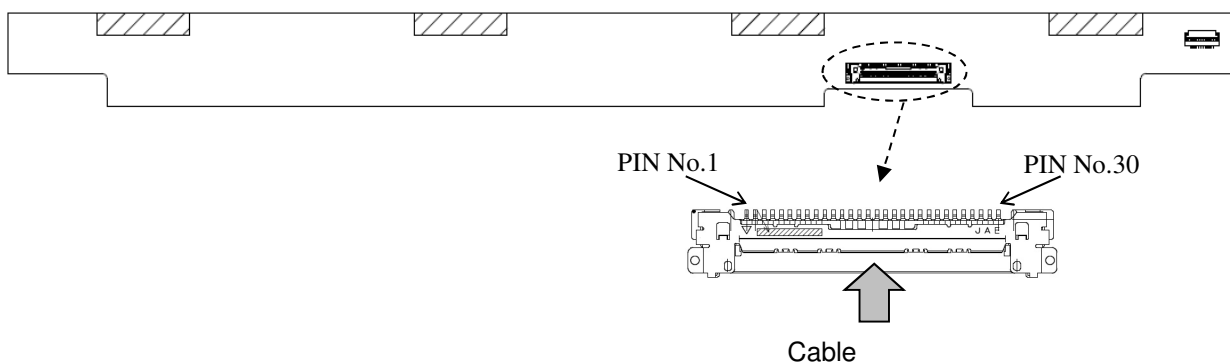

5.2 Correspondence between input data and display image

Display data of adjacent two pixel is latched during four cycle of DCLK(Dot clock).

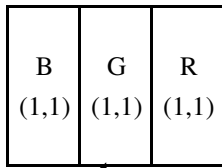

Pixel : B0 - B7 : B (x,y)
 G0 - G7 : G (x,y)
 R0 - R7 : R (x,y)

1, 1	1, 2	1, 3	-----	1, 1920
2, 1	2, 2	2, 3	-----	2, 1920
3, 1	3, 2	3, 3	-----	3, 1920
1080, 1	1080, 2	1080, 3		1080, 1920

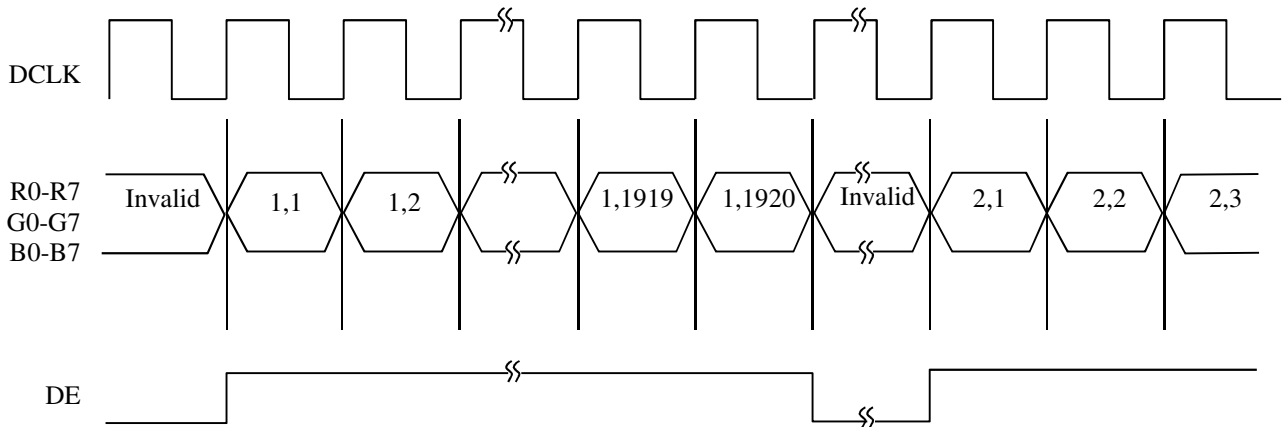

5. 3 Relationship between display colors and input signals

Input Color		Red Data								Green Data								Blue Data							
		R7	R6	R5	R4	R3	R2	R1	R0	G7	G6	G5	G4	G3	G2	G1	G0	B7	B6	B5	B4	B3	B2	B1	B0
		MSB				LSB				MSB				LSB				MSB				LSB			
Basic Color	Black	0	0	0	0	0	0	0	0	0	0	0	0	0	0	0	0	0	0	0	0	0	0	0	0
	Red(255)	1	1	1	1	1	1	1	1	0	0	0	0	0	0	0	0	0	0	0	0	0	0	0	0
	Green(255)	0	0	0	0	0	0	0	0	1	1	1	1	1	1	1	1	0	0	0	0	0	0	0	0
	Blue(255)	0	0	0	0	0	0	0	0	0	0	0	0	0	0	0	0	1	1	1	1	1	1	1	1
	Cyan	0	0	0	0	0	0	0	0	1	1	1	1	1	1	1	1	1	1	1	1	1	1	1	1
	Magenta	1	1	1	1	1	1	1	1	0	0	0	0	0	0	0	0	1	1	1	1	1	1	1	1
	Yellow	1	1	1	1	1	1	1	1	1	1	1	1	1	1	1	1	0	0	0	0	0	0	0	0
	White	1	1	1	1	1	1	1	1	1	1	1	1	1	1	1	1	1	1	1	1	1	1	1	1
Red	Black	0	0	0	0	0	0	0	0	0	0	0	0	0	0	0	0	0	0	0	0	0	0	0	0
	Red (1)	0	0	0	0	0	0	0	1	0	0	0	0	0	0	0	0	0	0	0	0	0	0	0	0
	Red (2)	0	0	0	0	0	0	1	0	0	0	0	0	0	0	0	0	0	0	0	0	0	0	0	0
	:	:	:	:	:	:	:	:	:	:	:	:	:	:	:	:	:	:	:	:	:	:	:	:	:
	:	:	:	:	:	:	:	:	:	:	:	:	:	:	:	:	:	:	:	:	:	:	:	:	:
	Red(254)	1	1	1	1	1	1	1	0	0	0	0	0	0	0	0	0	0	0	0	0	0	0	0	0
	Red(255)	1	1	1	1	1	1	1	1	0	0	0	0	0	0	0	0	0	0	0	0	0	0	0	0
Green	Black	0	0	0	0	0	0	0	0	0	0	0	0	0	0	0	0	0	0	0	0	0	0	0	0
	Green (1)	0	0	0	0	0	0	0	0	0	0	0	0	0	0	0	1	0	0	0	0	0	0	0	0
	Green (2)	0	0	0	0	0	0	0	0	0	0	0	0	0	0	1	0	0	0	0	0	0	0	0	0
	:	:	:	:	:	:	:	:	:	:	:	:	:	:	:	:	:	:	:	:	:	:	:	:	:
	:	:	:	:	:	:	:	:	:	:	:	:	:	:	:	:	:	:	:	:	:	:	:	:	:
	Green(254)	0	0	0	0	0	0	0	0	1	1	1	1	1	1	1	0	0	0	0	0	0	0	0	0
	Green(255)	0	0	0	0	0	0	0	0	1	1	1	1	1	1	1	1	0	0	0	0	0	0	0	0
Blue	Black	0	0	0	0	0	0	0	0	0	0	0	0	0	0	0	0	0	0	0	0	0	0	0	0
	Blue (1)	0	0	0	0	0	0	0	0	0	0	0	0	0	0	0	0	0	0	0	0	0	0	0	1
	Blue (2)	0	0	0	0	0	0	0	0	0	0	0	0	0	0	0	0	0	0	0	0	0	0	1	0
	:	:	:	:	:	:	:	:	:	:	:	:	:	:	:	:	:	:	:	:	:	:	:	:	:
	:	:	:	:	:	:	:	:	:	:	:	:	:	:	:	:	:	:	:	:	:	:	:	:	:
	Blue (254)	0	0	0	0	0	0	0	0	0	0	0	0	0	0	0	0	1	1	1	1	1	1	1	0
	Blue (255)	0	0	0	0	0	0	0	0	0	0	0	0	0	0	0	0	1	1	1	1	1	1	1	1

Note 1) Definition of gray scale :
 Color(n) · · · · Number in parenthesis indicates gray scale level.
 Larger n corresponds to brighter level.
 2) Data : 1 : High, 0 : Low

6. INTERFACE TIMING

6.1 eDP receiver characteristics

(1) DisplayPort Main Link Receiver Characteristics

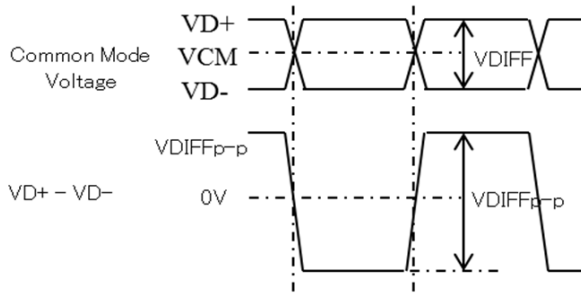

Symbol	Description	Min.	Typ.	Max.	Unit	Comments
VDIFFp-p	Differential peak-to-peak input voltage	120	-	1200	mV	For HBR.
VCM	DC common mode voltage	0	-	2.0	V	
RTERM	Differential termination resistance	-	100	-	Ω	
ISHORT	Short circuit current limit	-	-	50	mA	
LSKEW	Lane Intra-pair skew	-	-	100	ps	For HBR.

(2) DisplayPort AUX Channel Characteristics

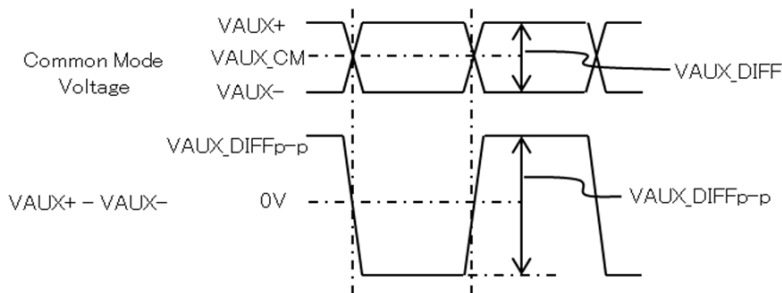

Symbol	Description	Min.	Typ.	Max.	Unit	Comments
UI	AUX Unit interval	0.4	0.5	0.6	us	
VAUX_DIFFp-p	AUX Differential peak-to-peak input voltage	0.32	-	1.32	V	
VAUX_CM	AUX DC common mode voltage	0	-	2.0	V	
RAUX_TERM	AUX CH termination resistance	-	100	-	Ω	
IAUX_SHORT	AUX Short circuit current limit	-	-	90	mA	
CAUX	AUX AC coupling capacitor	-	100	-	nF	1)

Note 1) Coupling capacitor is not mounted on our PCB.

6. 2 eDP 2lane 8bit input data mapping

Lane0	Lane1
R1-7:0	R2-7:0
G1-7:0	G2-7:0
B1-7:0	B2-7:0
R3-7:0	R4-7:0
G3-7:0	G4-7:0
B3-7:0	B4-7:0
R5-7:0	R6-7:0
G5-7:0	G6-7:0
B5-7:0	B6-7:0

6. 3 SYNCRONIZATION SIGNAL TIMING

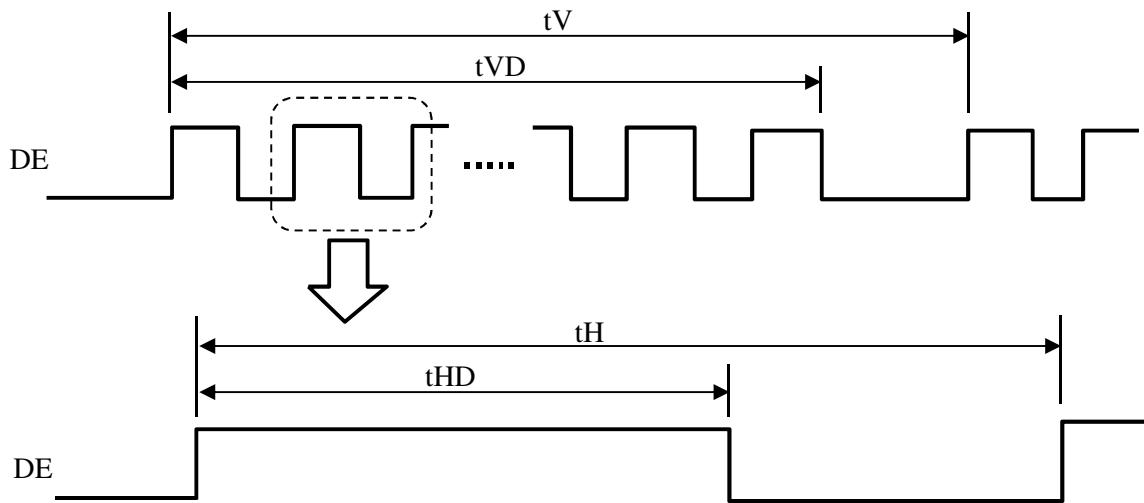

Frame rate 60Hz

	ITEM	SYMBOL	Min.	Typ.	Max.	UNIT	NOTE
DE	Vertical Period	tV	1092	1093	1094	tH	
	Vertical Valid	tVD	1080			tH	
	Horizontal Period	tH	2040	2264	2265	tCLK	
	Horizontal Valid	tHD	1920			tCLK	

6. 4 Timing between interface signals and power supply

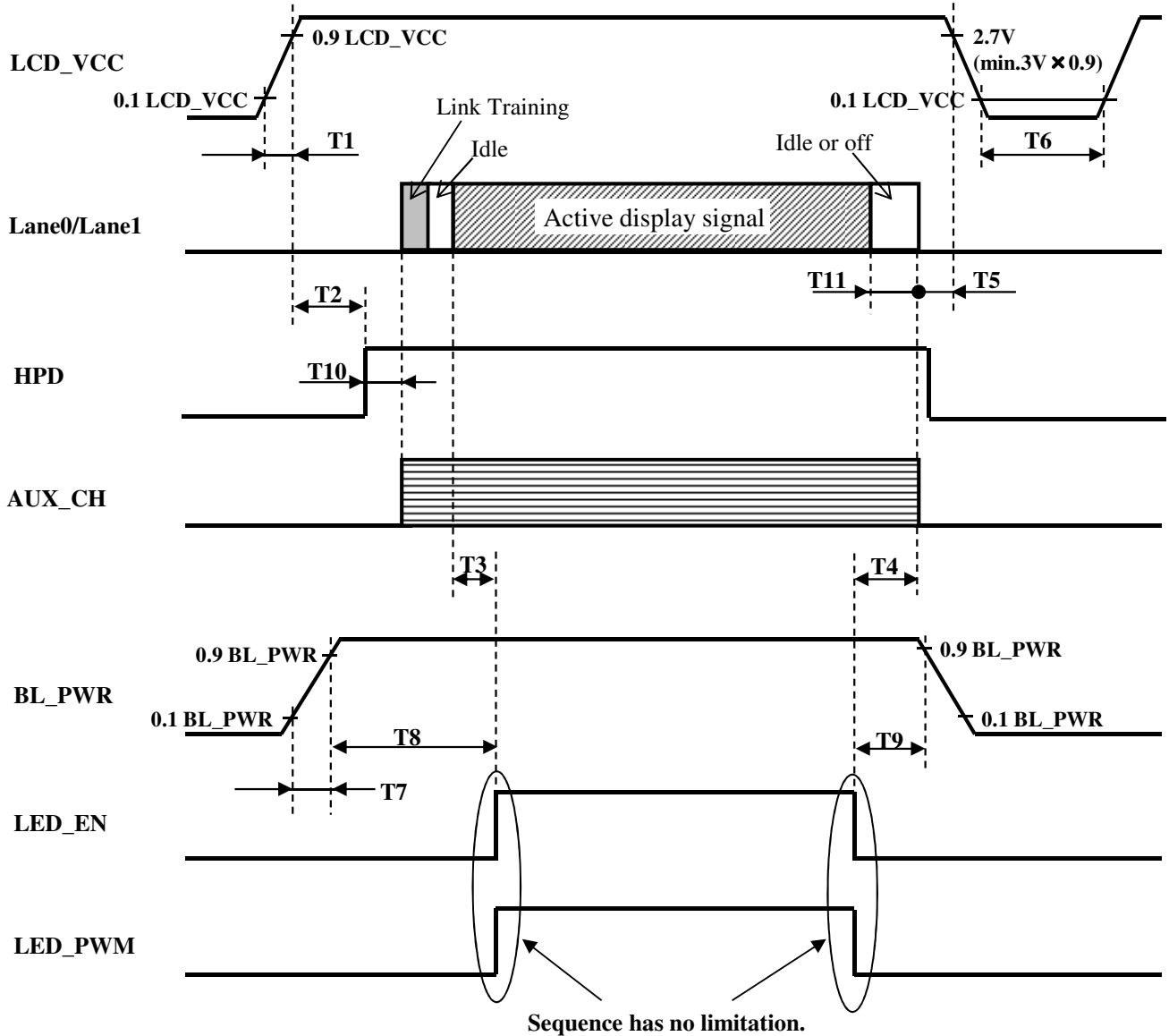

SYMBOL	Min.	Typ.	Max.	UNIT	Note
T1	0.5	1	10	ms	
T2	-	-	200	ms	
T3	33	-	-	ms	
T4	0	-	-	ms	
T5	0	-	-	ms	
T6	500	-	-	ms	1)
T7	0.5	-	-	ms	
T8	0	-	-	ms	
T9	0	-	-	ms	
T10	0	-	-	ms	
T11	0	-	-	ms	

Note 1) Please discharge LCD_VCC below 50mV (duration is over 1ms) before re-power on.

7. LABEL FORMAT

7.1 Label

The label is on the metallic bezel as shown in External Dimensional.

The style of character will be changed without notice.

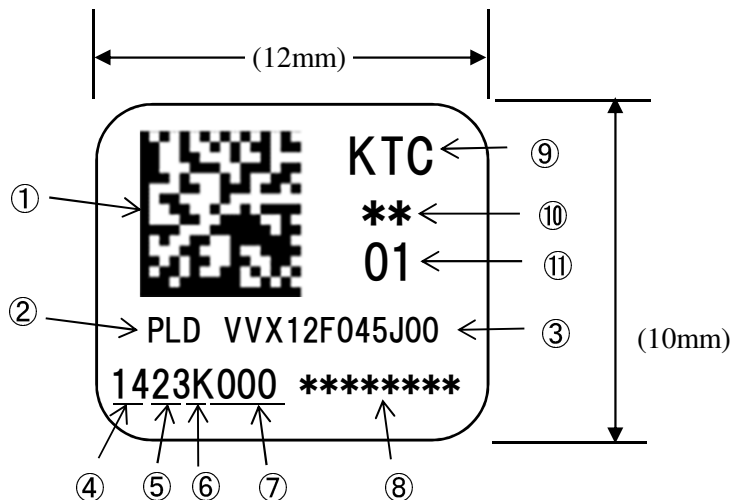

- ① Contents of ②~⑪ are indicated by bar codes. 【Express by the data matrix】
- ② PLD
- ③ VVX12F045J00
- ④ Please refer Note 1)
- ⑤ Please refer Note 2)
- ⑥ Please refer Note 3)
- ⑦ 4 digits for serial number (0001 - ZZZZ) without I and U and U and V.
- ⑧ A code for production of PLD inside management.
- ⑨ Please refer Note 4)
- ⑩ A suffix for PLD inside management.
- ⑪ Please refer Note 5)

Note 1)

Mark	Year
14	2014
15	2015
16	2016

Note 2)

- 01 , The 1st week of year
- 02 , The 2nd week of year
- 03 , The 3rd week of year
- 04 , The 4th week of year
- 05 , The 5th week of year
- 06 , The 6th week of year
-
- 52 , The 52th week of year

Note 3)

- Production base
- G : Panasonic Okayama
- K : Kentec

Note 4)

- Production base
- GMC : Panasonic Okayama
- KTC : Kentec

Note 5)

- WS : WS
- E1 : ES1
- CS : CS
- CS2 : C2
- MP : 01 - ZZ

7.2 Record of revision described on the label

Rev.C2: BL optical sheets composition is Upper diffuser/Upper prism/Lower prism/Lower diffuser.

Rev.01: BL optical sheets composition is Upper diffuser 1/Upper diffuser 2/Upper prism/Lower prism/Lower diffuser.

Panasonic Liquid Crystal Display Co.,Ltd.	Date	Sep.17.2015	Sheet No.	Confidential Until : indefinite	ATD-11215	Page	10-2/2
-------------------------------------------------	------	-------------	-----------	-------------------------------------------	-----------	------	--------

9. PRECAUTION

Please pay attention to the followings when a TFT module with a backlight unit is used, handled and mounted.

9.1 Precaution to handling and mounting

- (1) Applying strong force to a part of the module may cause partial deformation of frame or mold, and cause damage to the display.
- (2) The module should gently and firmly be held by both hands. Never hold by just one hand in order to avoid any internal damage. Never drop or hit the module.
- (3) Uneven force such as twisted stress should not be applied to a module when a module is mounted on the cover case. The cover case must have sufficient strength so that external force can not be transmitted directly to a module.
- (4) It is recommended to leave a space between a module and a holding board of a module so that partial force is not applied to a module.

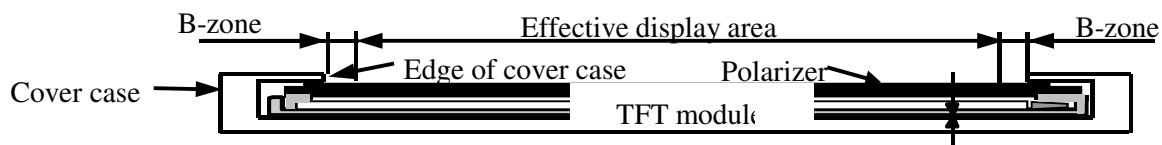

Fig.1 Cross sectional view of a monitor set

- (5) The edge of a cover case should be located inside more than 1mm from the edge of a polarizer edge.
- (6) A transparent protective plate should be added on the display area of a module in order to protect a polarizer and TFT cell. The transparent protective plate should have sufficient strength so that the plate can not touch a module by external force.
- (7) Materials included acetic acid and chlorine should not be used for a cover case as well as other parts and boards near a module. Acetic acid attacks a polarizer. Chlorine attacks electric circuits due to electro-chemical reaction.
- (8) The polarizer on a TFT cell should carefully be handled due to its softness, and should not be touched, pushed or rubbed with glass, tweezers or anything harder than HB pencil lead. The surface of a polarizer should not be touched and rubbed with bare hand, greasy clothes or dusty clothes.
- (9) The surface of a polarizer should be gently wiped with absorbent cotton, chamois or other soft materials slightly contained petroleum benzene when the surface becomes dirty. Normal-hexane or Isopropyl alcohol as cleaning chemicals is recommended in order to clean adhesives which fix front/rear polarizers on a TFT cell. Other cleaning chemicals such as acetone, toluen and alcohol should not be used to clean adhesives because they cause chemical damage to a polarizer.
- (10) Saliva or water drops should be immediately wiped off. Otherwise, the portion of a polarizer may be deformed and its color may be faded.
- (11) The module should not be opened or modified. It may cause not to operate properly.
- (12) A module should not be handled with bare hand or dirty gloves. Otherwise, color of a module fixed sheet and metal frame may become dirty during its storage. It is recommended to use clean soft gloves and clean finger stalls when a module is handled at incoming inspection process and production (assembly) process.
- (13) Printed circuits board part should not be held and touched. It may cause not to operate properly.

9.2 Precaution to operation

- (1) The ambient temperature near the operated module should be satisfied with the absolute maximum ratings. Unless it meets the specifications, sufficient cooling system should be adopted to system.
- (2) The spike noise causes the mis-operation of a module. The level of spike noise should be as follows:
$$-100\text{mV} \leq \text{over- and under- shoot of VDD} \leq +100\text{mV}$$
VDD including over- and under- shoot should be satisfied with the absolute maximum ratings.
- (3) Optical response time, luminance and chromaticity depend on the temperature of a TFT module.
- (4) Sudden temperature change may cause dew on and/or in the a module. Dew makes damage to a polarizer and/or electrical contacting portion. Dew causes fading of displayed quality.
- (5) Fixed patterns displayed on a module for a long time may cause after-image. It will be recovered soon.
- (6) A module has high frequency circuits. Sufficient suppression to electromagnetic interference should be done by system manufacturers. Grounding and shielding methods may be effective to minimize the interference.
- (7) Noise may be heard when a backlight is operated. If necessary, sufficient suppression should be done by system manufacturers.
- (8) The module should not be connected or removed while a main system works.
- (9) Inserting or pulling I/F connectors causes any trouble when power supply and signal data are on-state. I/F connectors should be inserted and pulled after power supply and signal data are turned off.

9.3 Electrostatic discharge control

- (1) Since a module consists of a TFT cell and electronic circuits with CMOS-ICs, which are very weak to electrostatic discharge, persons who are handling a module should be grounded through adequate methods such as a list band. I/F connector pins should not be touched directly with bare hands.
- (2) Protection film for a polarizer on a module should be slowly peeled off so that the electrostatic charge can be minimized.

9.4 Precaution to strong light exposure

- (1) A module should not be exposed under strong light. Otherwise, characteristics of a polarizer and color filter in a module may be degraded.

9.5 Precaution to storage

When modules for replacement are stored for a long time, following precautions should be taken care of:

- (1) Modules should be stored in a dark place. It is prohibited to apply sunlight or fluorescent light during storage. Modules should be stored at 0 to 35°C at normal humidity (60%RH or less).
- (2) The surface of polarizers should not come in contact with any other object. It is recommended that modules should be stored in the Panasonic Liquid Crystal Display's shipping box.

9.6 Precaution to handling protection film

- (1) The protection film for polarizers should be peeled off slowly and carefully by persons who are electrically grounded with adequate methods such as a list band. Besides, ionized air should be blown over during peeling action. Dusts on a polarizer should be blown off by an ionized nitrogen gun and so on.
- (2) The protection film should be peeling off without rubbing it to the polarizer. Because, if the film is rubbed together with the polarizer, since the film is attached to the polarizer with a small amount of adhesive, the adhesive may remain on a polarizer.

- (3) The module with protection film should be stored on the conditions explained in 9.5 (1). However, in case that the storage time is too long, adhesive may remain on a polarizer even after a protection film is peeled off. Besides, in case that a module is stored at higher temperature and/or higher humidity, adhesive may remain on a polarizer. The remained adhesive may cause non-uniformity of display image.
- (4) The adhesive can be removed easily with Normal-Hexane or Isopropyl alcohol. The remained adhesive or its vestige on the polarizer should be wiped off with absorbent cotton or other soft materials such as chamois slightly contained Normal-Hexane or Isopropyl alcohol.

9.7 Safety

- (1) Since a TFT cell is made of glass, handling to the broken module should be taken care sufficiently in order not to be injured. Hands touched liquid crystal from a broken cell should be washed sufficiently.
- (2) The module should not be taken apart during operation so that backlight drives by high voltage.

9.8 Environmental protection

Flexible printed circuits and printed circuits board used in a module contain small amount of lead. Please follow local ordinance or regulations for its disposal.

9.9 Use restrictions and limitations

- (1) This product is not authorized for use in life support devices or systems, military applications or other applications which pose a significant risk of personal injury.
- (2) In no event shall Panasonic Liquid Crystal Display Co.,Ltd., be liable for any incidental, indirect or consequential damages in connection with the installation or use of this product, even if informed of the possibility thereof in advance. These limitations apply to all causes of action in the aggregate, including without limitation breach of contract, breach of warranty, negligence, strict liability, misrepresentation and other torts.

9.10 Others

Electrical components which may not affect electrical performance are subjective to change without notice because of their availability.

Panasonic Liquid Crystal Display Co.,Ltd.	Date	Sep.17.2015	Sheet No.	<div style="border: 1px solid red; padding: 2px; display: inline-block;">Confidential</div> <small>Until : Indefinite</small>	ATD-11215	Page	12-3/3
-------------------------------------------------	------	-------------	-----------	----------------------------------------------------------------------------------------------------------------------------------	-----------	------	--------

10. PACKING

10.1 Precaution to handling and mounting

1) Standard packing specification

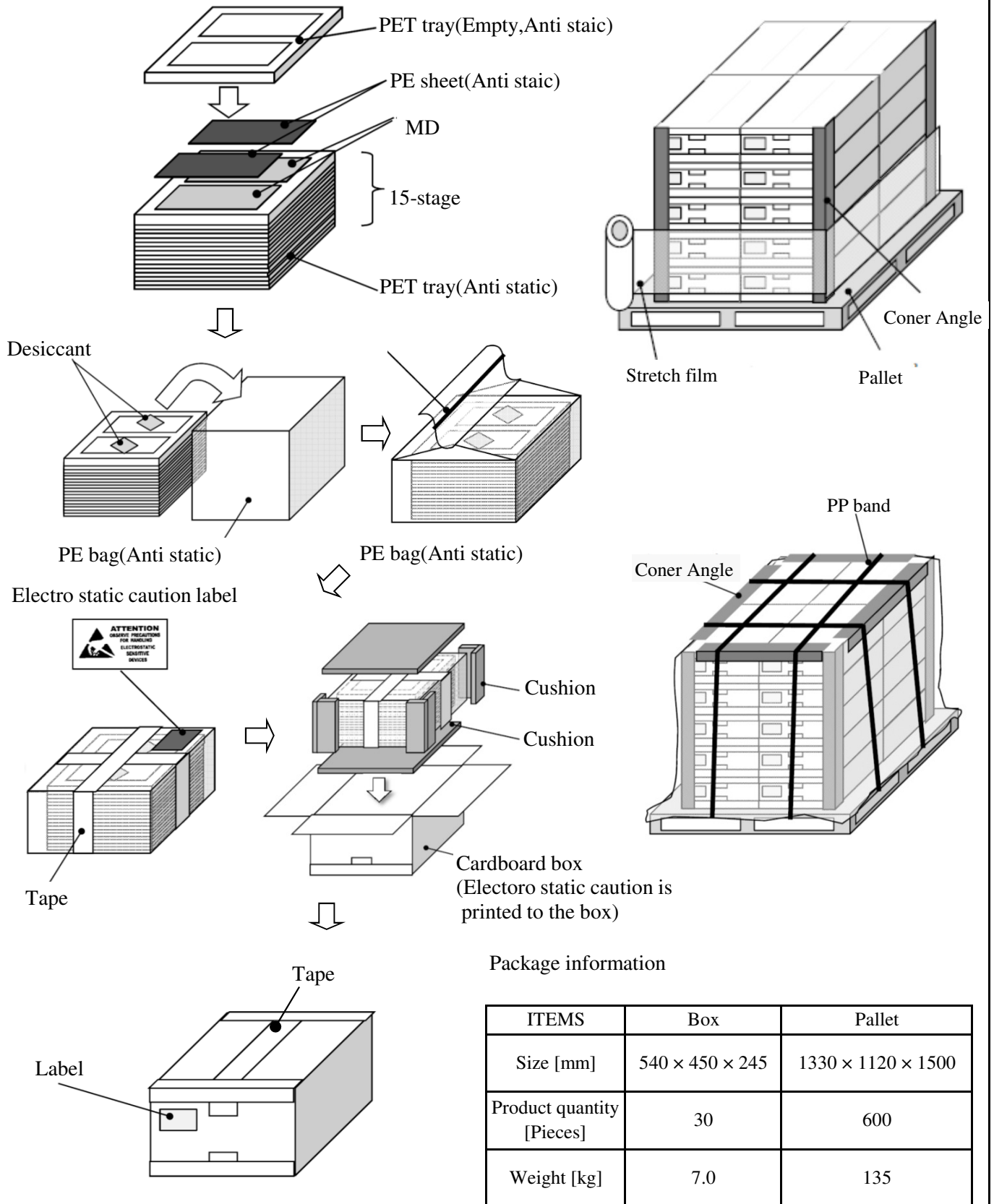

10.2 Label sample of packing box

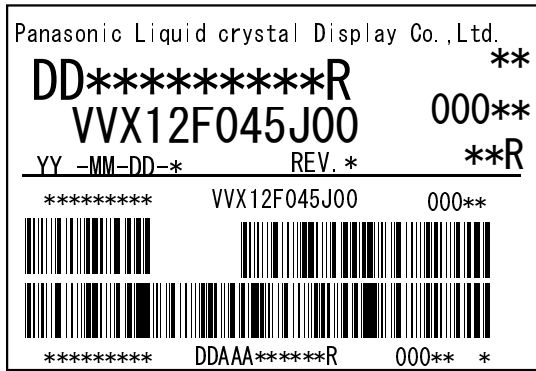

production slip (ex.)
label size (102 × 70)

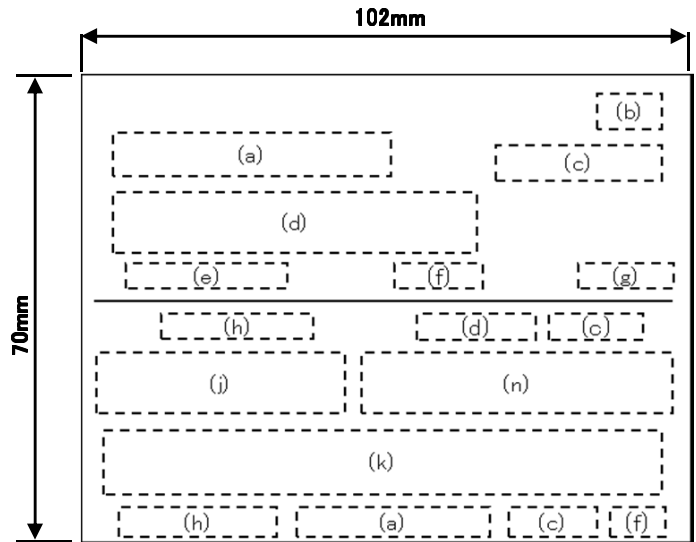

Code	Contents of Printing
(a)	PLD internal code.
(b)	The place of issuing label.
(c)	Quantity of the product (pcs)
(d)	Product name
(e)	Lot of registration
(f)	Revision (Rev.)
(g)	Last 3 digits of item code (outside Rev.)
(h)	Serial No. of identification tag
(j)	Bar code corresponds to (h).
(k)	Bar codes correspond to (h), (a),(c) and (f).
(n)	Bar codes correspond to (d), (c).

11. Dimensional outline

<Front view>

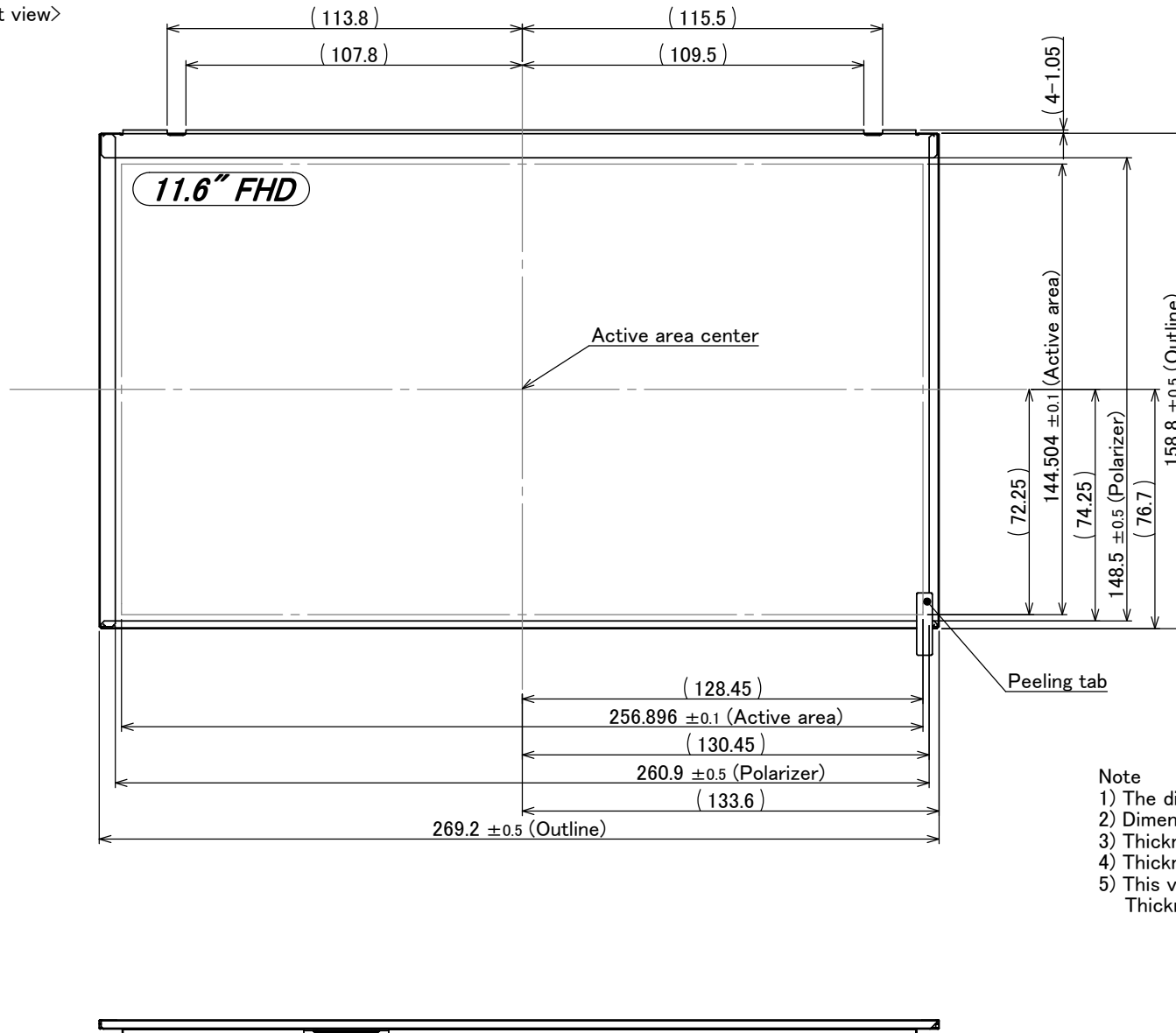

Note

- 1) The dimension in a parenthesis is a reference value.
- 2) Dimensional tolerance to be $\pm 0.8\text{mm}$ otherwise specified.
- 3) Thickness of Label and BL label on backside are 0.1mmt.
- 4) Thickness measurement force is 7~9N.
- 5) This value is on the highest electric component point.
Thickness measurement force is 7~9N.

<Back view>

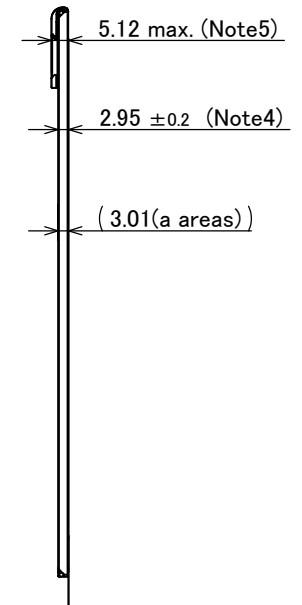
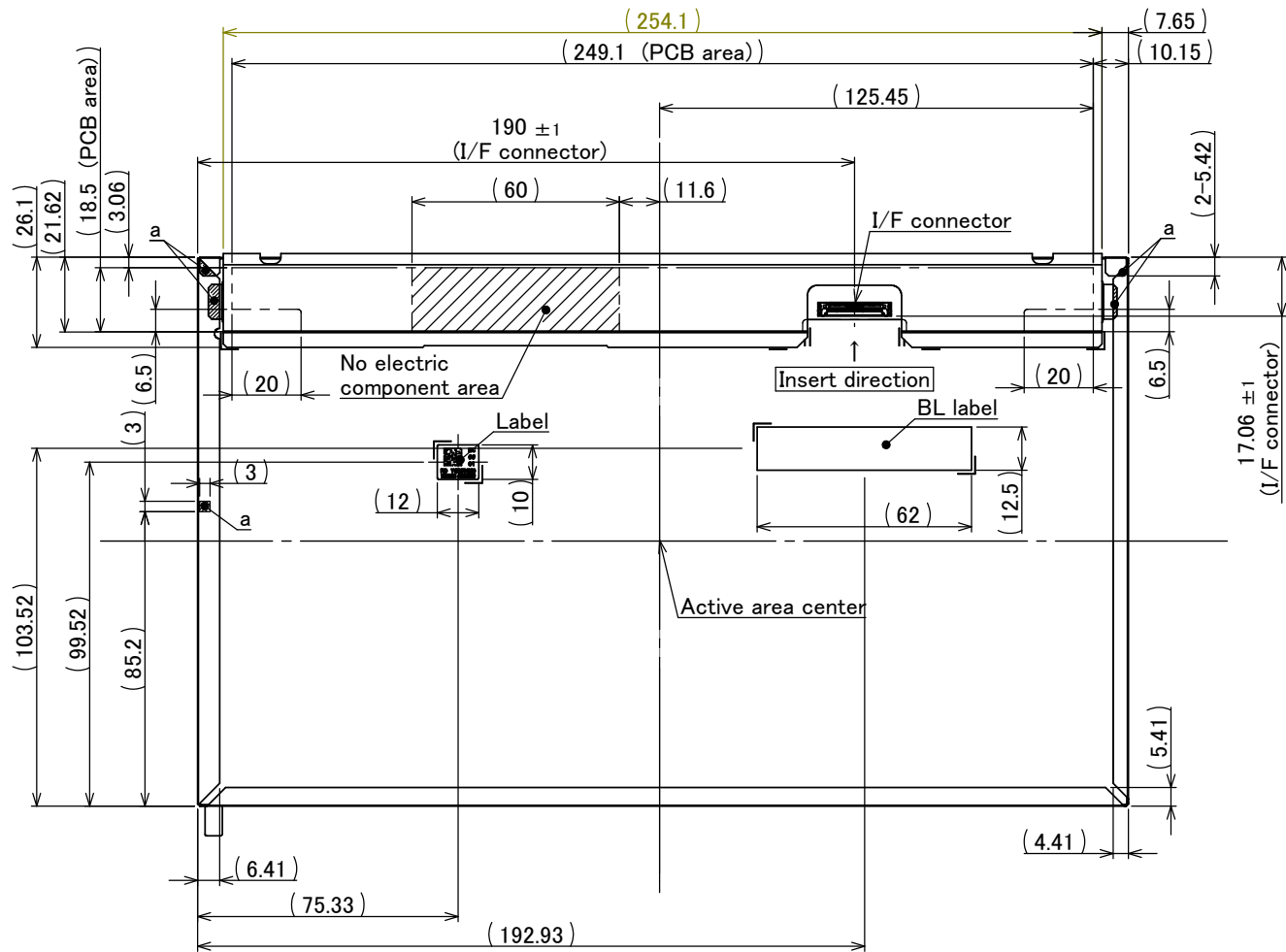

Our company network supports you worldwide with offices in Germany, Austria, Switzerland, the UK and the USA. For more information please contact:

Headquarters

Germany



FORTEC Elektronik AG

Lechwiesenstr. 9
86899 Landsberg am Lech

Phone: +49 8191 91172-0
E-Mail: sales@forteca.de
Internet: www.forteca.de

Fortec Group Members

Austria



FORTEC Elektronik AG

Office Vienna

Nuschinggasse 12
1230 Wien

Phone: +43 1 8673492-0
E-Mail: office@fortec.at
Internet: www.fortec.at

Germany



Distec GmbH

Augsburger Str. 2b
82110 Germering

Phone: +49 89 894363-0
E-Mail: info@distec.de
Internet: www.distec.de

Switzerland



ALTRAC AG

Bahnhofstraße 3
5436 Würenlos

Phone: +41 44 7446111
E-Mail: info@altrac.ch
Internet: www.altrac.ch

United Kingdom



Display Technology Ltd.

Osprey House, 1 Osprey Court
Hichingbrooke Business Park
Huntingdon, Cambridgeshire, PE29 6FN

Phone: +44 1480 411600
E-Mail: info@displaytechnology.co.uk
Internet: www.displaytechnology.co.uk

USA



Apollo Display Technologies, Corp.

87 Raynor Avenue,
Unit 1 Ronkonkoma,
NY 11779

Phone: +1 631 5804360
E-Mail: info@apolloDisplays.com
Internet: www.apolloDisplays.com