

ALC-133004-02-1

~ 13.3" High Brightness TFT LCD

2017/7/26

Preliminary Specifications v.0.1

Preliminary Specifications

Final Specifications

[This specification is subject to
change without notice.]

Company Confidential



Customer Name		Customer Approval
CiVUE Optotech Inc.		
Approved by	Checked by	Prepared by
周秉毅	汪慈伶	吳婧瑜

PROPRIETARY NOTICE

This document is a proprietary of CiVUE Optotech Inc. (CiVUE™), and is copyrighted with all rights reserved. Under the copyright laws, no part of this document can be distributed, reproduced, or disclosed in any forms, or by all means for any purpose, without prior written permission of CiVUE.

CiVUE reserves the right to make any changes in this document without notice. Please contact CiVUE for the latest specification.

RECORD OF REVISION

Version	Date	Page	Original Description	New Description	ECN#
0.0	2017/02/10	All	First draft	All	N/A
\$%.....	2017/07/26	P13		I dXUHY' 6UW][\h7i ffYbh	N/A

TABLE OF CONTENTS

1. General Description.....	4
1.1 General Specification	4
1.2 Optical Characteristics.....	5
2. Functional Block Diagram	9
3. Absolute Maximum Ratings	10
3.1 Absolute Ratings of TFT LCD Module	10
3.2 Absolute Ratings of Environment	10
4. Electrical Characteristics	11
4.1 TFT LCD Module	11
4.2 Backlight Unit	13
5. Signal Interface Characteristic	14
5.1 Pixel Format Image	14
5.2 The Input Data Format	15
5.3 Signal Description (CN1)	16
5.4 Interface Timing (LVDS)	17
5.5 Power ON/OFF Sequence	19
6. Connector & Pin Assignment.....	20
6.1 TFT LCD Module	20
6.2 Backlight Unit	21
7. Panel Reliability Test	23
8. Package	24
9. Mechanical Characteristics	25
9.1 LCM Outline Dimension (Front View)	25
9.2 LCM Outline Dimension (Rear View)	26

1. General Description

ALC-133004-02-1 is a Color Active Matrix Liquid Crystal Display composed of a TFT LCD panel, a TFT driver circuit, and LED backlight system. The screen format is intended to support the 16:9 FHD, 1920(H) x1080(V) screen and 16.7M colors (RGB 8-bits data driver).

1.1 General Specification

The following items are characteristics summary on the table at 25 °C condition:

Items	Unit	Specifications
Screen Diagonal	[inch]	13.3"
Active Area	[mm]	293.472 (H) x 165.078 (V)
Pixels H x V		1920 x 3(RGB) x 1080
Pixel Pitch	[mm]	0.15285x 0.15285
Pixel Format		R.G.B. Vertical Stripe
Display Mode		AHVA
White Luminance (Center)	[cd/m ²]	1000 Typ.
Luminance Uniformity		80% (5 points, Typ.)
Contrast Ratio		800:1 (Typ.)
Response Time	[ms]	25 (Typ.)/ 35 (Max.)
Nominal Input Voltage VDD	[Volt]	+3.3 (Typ.)
LCD Power Consumption	[Watt]	1.8 W (Max. White Pattern)
Backlight Power Consumption	[Watt]	13.5 (Typ.)
Weight	[Grams]	500 (Max.)
Physical Size	[mm]	309.7 x 184.1 x 9.6 (Typ.)
Electrical Interface		LVDS
Surface Treatment		Anti-glare
Support Color		16.7M Colors (RGB 8-bits)
Temperature Range		
Operating	[°C]	0 to +70
Storage (Non-Operating)	[°C]	0 to +70

1.2 Optical Characteristics

The optical characteristics are measured under stable conditions at 25°C (Room Temperature) :

Item	Unit	Conditions	Min.	Typ.	Max.	Note			
Central Luminance	cd/m2		800	1000	---	1, 3, 4			
Viewing Angle	degree	Horizontal (Right)	75	89	---	3, 7			
		(Left)	75	89	---				
	Vertical	(Upper)	75	89	---				
		(Lower)	75	89	---				
Luminance Uniformity		5 Points	75	80	---	1, 2, 3			
Contrast Ratio			600	800	-	3, 5			
Response Time	msec	Rising + Falling	---	25	35	3, 6			
Color / Chromaticity Coodinates	Red	Rx	CIE 1931	0.625	0.675	0.725	3		
		Ry		0.266	0.316	0.366			
	Green	Gx		0.235	0.285	0.335			
		Gy		0.605	0.655	0.705			
	Blue	Bx		0.103	0.153	0.203			
		By		0.000	0.036	0.086			
	White	Wx		0.263	0.313	0.363			
		Wy		0.279	0.329	0.379			
	NTSC	%			-	90		-	

Note 1: 5 points position (Ref: Active area)

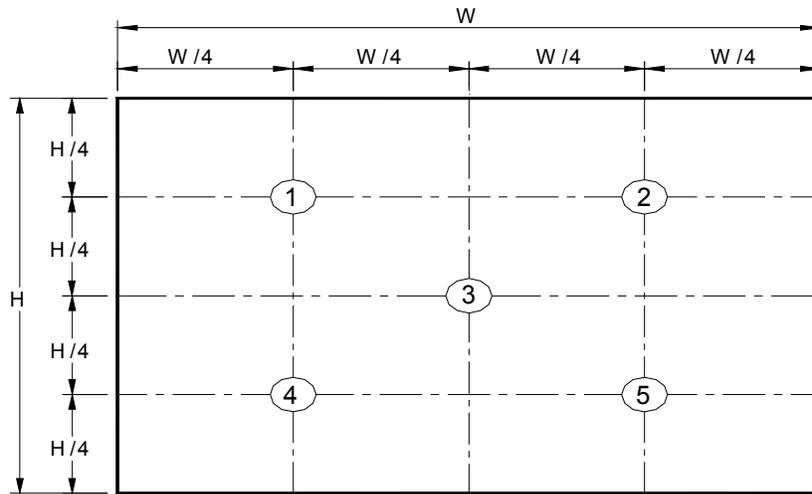

Note 2: The luminance uniformity of 5 points is defined by dividing the maximum luminance values by the minimum test point luminance

$$\delta_{w5} = \frac{\text{Maximum Brightness of five points}}{\text{Minimum Brightness of five points}}$$

Note 3: Measurement method

The LCD module should be stabilized at given temperature for 30 minutes to avoid abrupt temperature change during measuring. In order to stabilize the luminance, the measurement should be executed after lighting Backlight for 30 minutes in a stable, windless and dark room, and it should be measured in the center of screen.

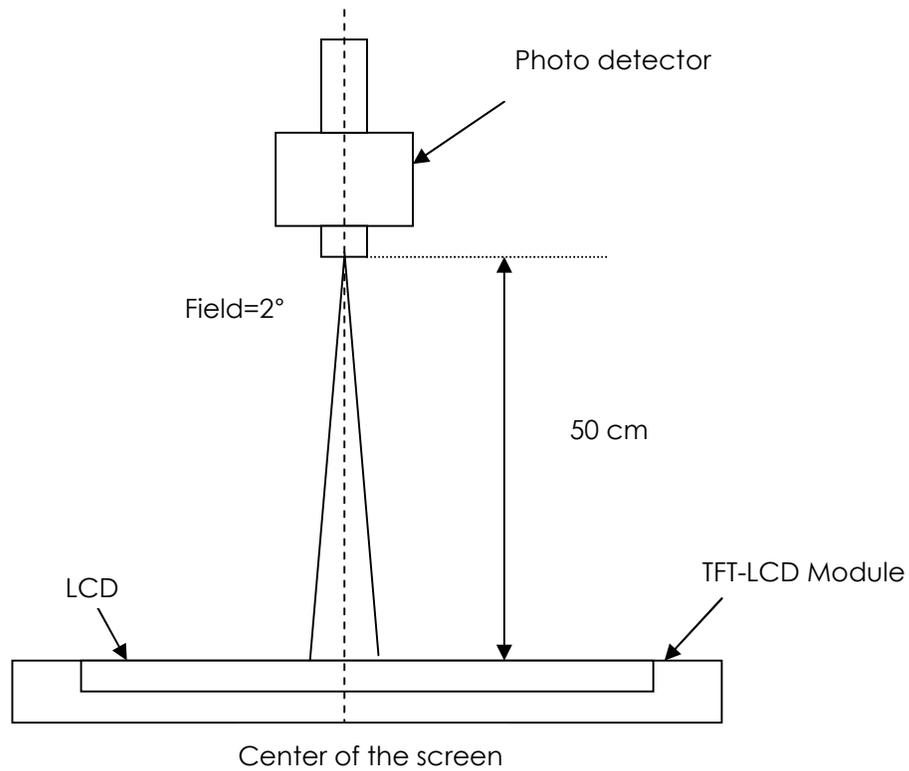

Note 4: Definition of Average Luminance of White (Y_L):

Measure the luminance of gray level 63 at 5 points , $Y_L = [L (1)+ L (2)+ L (3)+ L (4)+ L (5)] / 5$

$L (x)$ is corresponding to the luminance of the point X at Figure in Note (1).

Note 5: Definition of contrast ratio:

Contrast ratio is calculated with the following formula.

$$\text{Contrast ratio (CR)} = \frac{\text{Brightness on the "White" state}}{\text{Brightness on the "Black" state}}$$

Note 6: Definition of response time:

The output signals of BM-7 or equivalent are measured when the input signals are changed from "Black" to "White" (falling time) and from "White" to "Black" (rising time), respectively. The response time interval is between the 10% and 90% of amplitudes. Refer to figure as below.

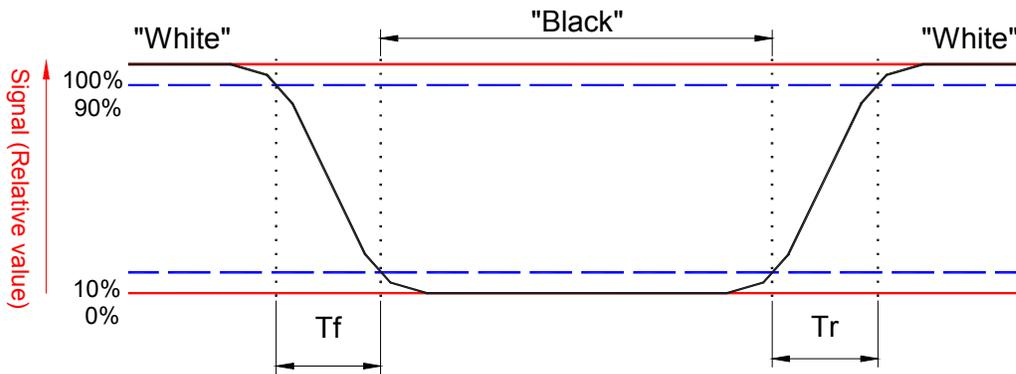

Note 7: Definition of viewing angle

Viewing angle is the measurement of contrast ratio >10, at the screen center, over a 180° horizontal and 180° vertical range (off-normal viewing angles). The 180° viewing angle range is broken down as follows; 90° (θ) horizontal left and right and 90° (Φ) vertical, high (up) and low (down). The measurement direction is typically perpendicular to the display surface with the screen rotated about its center to develop the desired measurement viewing angle.

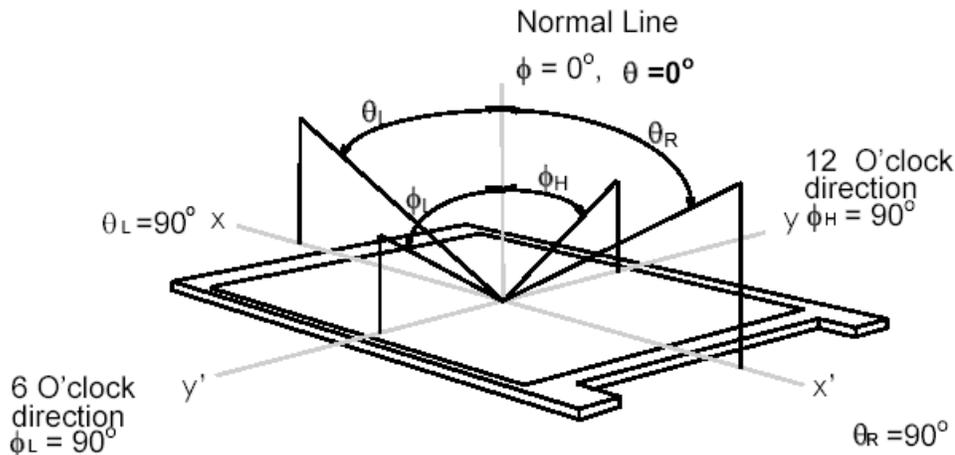

2. Functional Block Diagram

The following diagram shows the functional block of the 13.3 inch Color TFT-LCD Module:

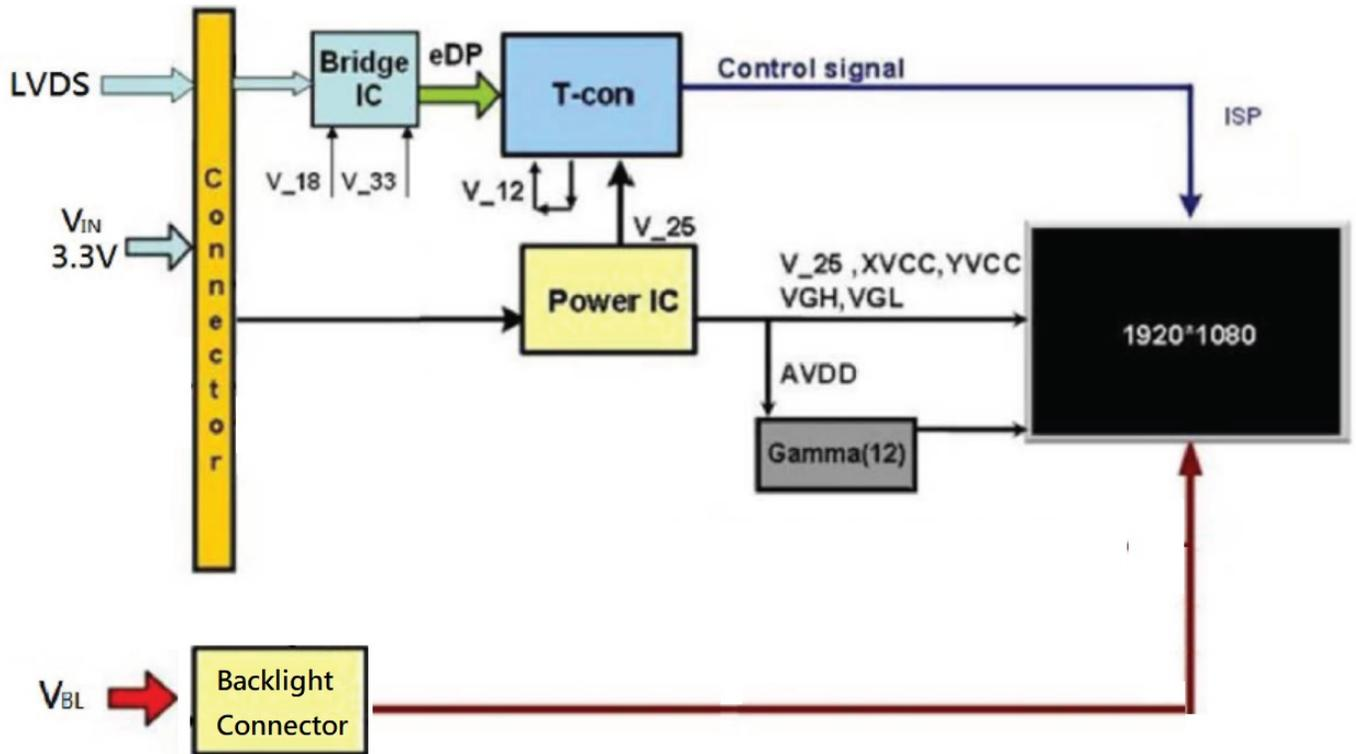

3. Absolute Maximum Ratings

An absolute maximum rating of the module is as following:

3.1 Absolute Ratings of TFT LCD Module

Item	Symbol	Min	Max	Unit	Conditions
Logic/LCD Drive Voltage	VDD	-0.3	+4.0	[Volt]	Note 1,2
Backlight Current	I _{BL}	---	395	[mA]	Note 1,2
Signal Voltage	RinI-/+, ClkIN-/+	-0.3	VDD+0.3	[Volt]	Note 1, I=0,1,2,3

3.2 Absolute Ratings of Environment

Item	Symbol	Min	Max	Unit	Conditions
Operating Temp.	TOP	0	+70	[°C]	
Operation Humidity	HOP	8	90	[%RH]	
Storage Temperature	TST	0	+70	[°C]	
Storage Humidity	HST	5	90	[%RH]	

Note 1: At Ta (25°C)

Note 2: Permanent damage to the device may occur if exceed maximum values

4. Electrical Characteristics

4.1 TFT LCD Module

4.1.1 Power Specification

Input power specifications are as follows;

The power specification are measured under 25°C and frame frequency under 60Hz

Symble	Parameter	Min	Typ	Max	Units	Note
VDD	Logic/LCD Drive Voltage	3.0	3.3	3.6	[Volt]	
PDD	VDD Power	-	-	1.8	[Watt]	Note 1
IDD	IDD Current	-	-	500	[mA]	Note 1
IRush	Inrush Current	-	-	2	[A]	Note 2
VDDrp	Allowable Logic/LCD Drive Ripple Voltage	-	-	200	[mV] p-p	

Note 1: Maximum Measurement Condition : White Pattern at 3.6V driving voltage ($P_{max}=V_{3.6} \times I_{white}$)

Note 2: Measure Condition

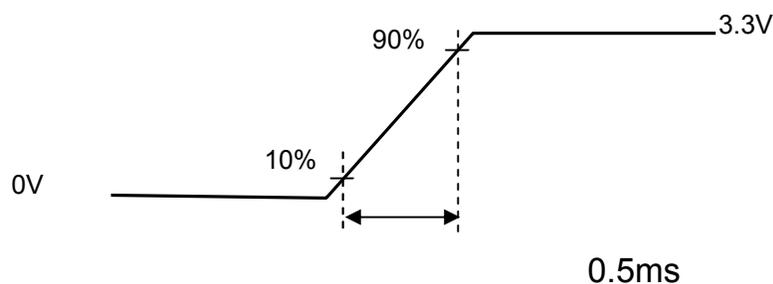
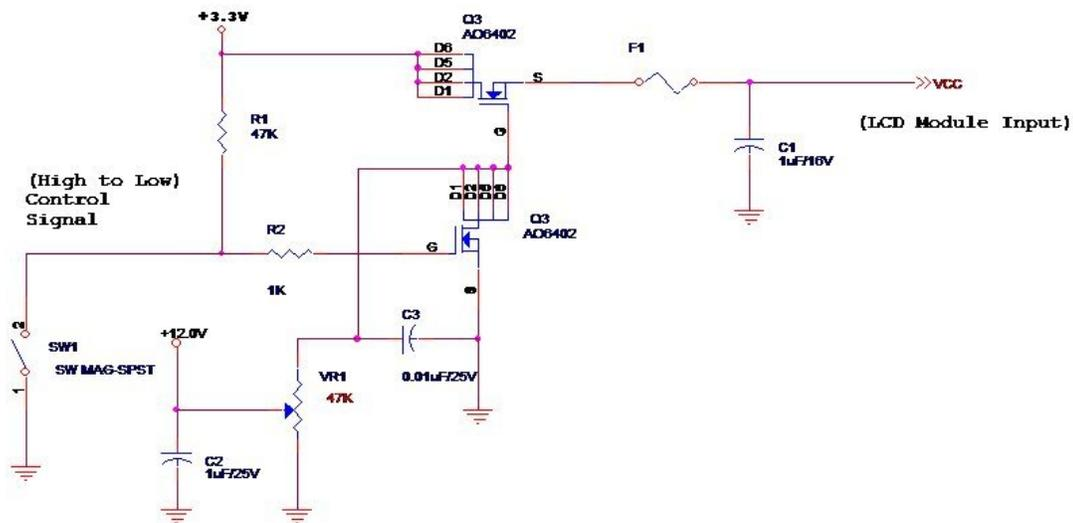

4.1.2 Signal Electrical Characteristics

Input signals shall be low or High-impedance state when VDD is off.

Signal electrical characteristics are as follows;

Symbol	Parameter	Min	Typ	Max	Units	Condition
V_{TH}	Differential Input High Threshold	-	-	+100	[mV]	$V_{CM} = 1.2V$ Note 1
V_{TL}	Differential Input Low Threshold	-100	-	-	[mV]	$V_{CM} = 1.2V$ Note 1
$ V_{ID} $	Input Differential Voltage	100	400	600	[mV]	Note 1
V_{CM}	Differential Input Common Mode Voltage	+1.125	-	+1.375	[Volt]	$V_{TH}-V_{TL} = 200mV$ (max) Note 1

Note 1: LVDS Signal Waveform

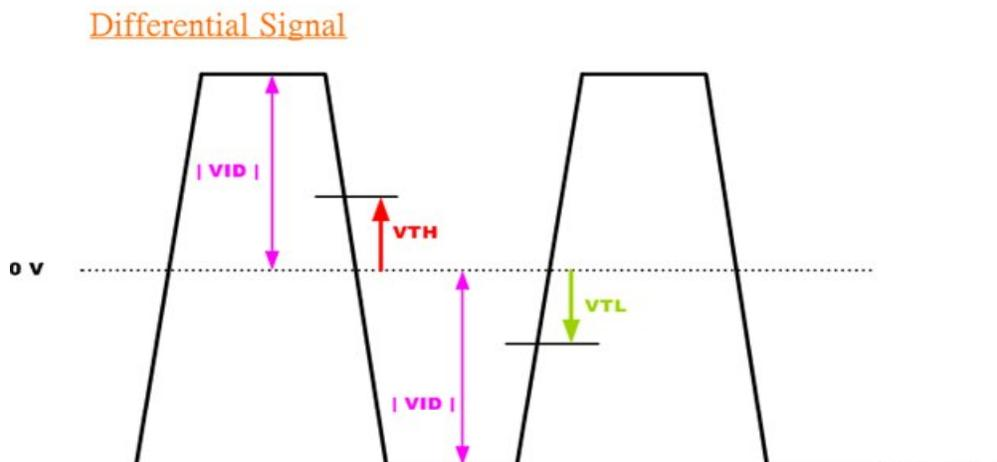
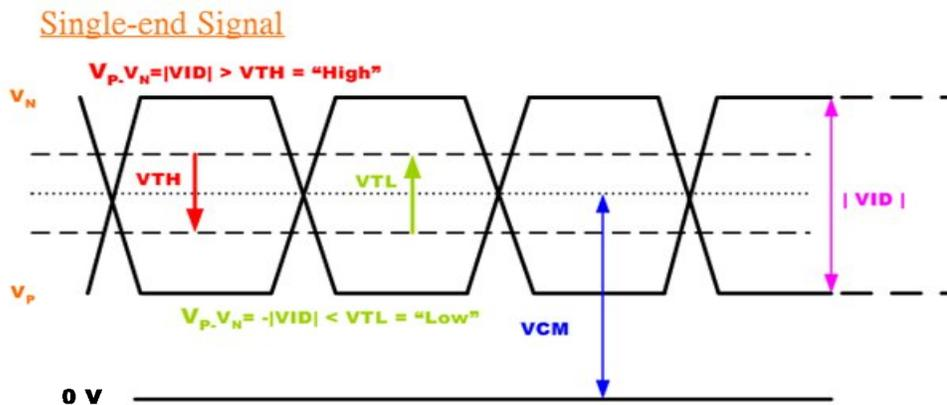

4.2 Backlight Unit

Following characteristics are measured under a stable condition using an inverter at 25°C (Room Temperature):

Symbol	Parameter	Min	Typ	Max	Units
I _{BL}	Backlight Forward Current	-	375	395	mA
V _{BL}	Backlight Forward Voltage	33.6	36.0	42	Volt
P _{BL}	Backlight Power Consumption	-	13.5	16.59	Watt
L _{BL}	Backlight Life Time	-	70,000	-	Hrs

E f K ` (1K_ \ C < ; ` c) \ \$ k d \ [\] ` e \ X j ` k _ \ \ j k d X k [` k d \ ` k f ` ; ' f l [\ ^ i X [X k f e ` f] ` e ` K X c d d ` e f l j %

5.2 The Input Data Format

Interface	Type	Data
LVDS	JEIDA	8 bit

JEIDA / NS Mapping Format (Using JEIDA)

RXIN1D0 N/P	J : RA6=G2	J : RA5=G7	J : RA4=G6	J : RA3=G5	J : RA2=R4	J : RA1=R3	J : RA0=R2
RXIN2D0 N/P	N : RA6=G0	N : RA5=R5	N : RA4=R4	N : RA3=R3	N : RA2=R2	N : RA1=R1	N : RA0=R0
RXIN1D1 N/P	J : RB6=B3	J : RB5=B2	J : RB4=G7	J : RB3=G6	J : RB2=G5	J : RB1=G4	J : RB0=G3
RXIN2D1 N/P	N : RB6=B1	N : RB5=B0	N : RB4=G5	N : RB3=G4	N : RB2=G3	N : RB1=G2	N : RB0=G1
RXIN1D2 N/P	J : RC6=DE	J : RC5=VS	J : RC4=HS	J : RC3=B7	J : RC2=B6	J : RC1=B5	J : RC0=B4
RXIN2D2 N/P	N : RC6=DE	N : RC5=VS	N : RC4=HS	N : RC3=B5	N : RC2=B4	N : RC1=B3	N : RC0=B2
RXIN1D3 N/P	J : RD6=X	J : RD5=B1	J : RD4=B0	J : RD3=G1	J : RD2=G0	J : RD1=R1	J : RD0=R0
RXIN2D3 N/P	N : RD6=X	N : RD5=B7	N : RD4=B6	N : RD3=G7	N : RD2=G6	N : RD1=R7	N : RD0=R6

5.3 Signal Description (CN1)

The module uses one LVDS receiver. LVDS is a differential signal technology for LCD interface and high speed data transfer device. The first LVDS port(RxOxxx) transmits odd pixels while the second LVDS port(RxExxx) transmits even pixels.

Pin	Signal	Description
1	RxOIN0-	Negative LVDS differential data input (Odd data)
2	RxOIN0+	Positive LVDS differential data input (Odd data)
3	RxOIN1-	Negative LVDS differential data input (Odd data)
4	RxOIN1+	Positive LVDS differential data input (Odd data)
5	RxOIN2-	Negative LVDS differential data input (Odd data, DSPTMG)
6	RxOIN2+	Positive LVDS differential data input (Odd data, DSPTMG)
7	GND	Power Ground
8	RxOCLKIN-	Negative LVDS differential clock input (Odd clock)
9	RxOCLKIN+	Positive LVDS differential clock input (Odd clock)
10	RxOIN3-	Negative LVDS differential data input (Odd data)
11	RxOIN3+	Positive LVDS differential data input (Odd data)
12	RxEIN0-	Negative LVDS differential data input (Even data)
13	RxEIN0+	Positive LVDS differential data input (Even data)
14	GND	Power Ground
15	RxEIN1-	Positive LVDS differential data input (Even data)
16	RxEIN1+	Negative LVDS differential data input (Even data)
17	GND	Power Ground
18	RxEIN2-	Negative LVDS differential data input (Even data)
19	RxEIN2+	Positive LVDS differential data input (Even data)
20	RxECLKIN-	Negative LVDS differential clock input (Even clock)
21	RxECLKIN+	Positive LVDS differential clock input (Even clock)
22	RxEIN3-	Negative LVDS differential data input (Even data)
23	RxEIN3+	Positive LVDS differential data input (Even data)
24	GND	Power Ground
25	B7	No Connection
26	VDD	Power +3.3V
27	VDD	Power +3.3V
28	B7	No Connection
29	B7	No Connection
30	GND	Power Ground

5.4 Interface Timing (LVDS)

5.4.1 Timing Characteristics

Basically, interface timings should match the 1920x1080/ 60Hz manufacturing guide line timing.

Parameter	Symbol	Min.	Typ.	Max.	Unit	
Frame Rate	-	60	60	60	Hz	
Clock frequency	$1/T_{Clock}$	134	141.2	149	MHz	
Horizontal Section	Period	T_H	2046	2108	1920+B	T_{clock}
	Active	T_{HD}	1920			
	Blanking	T_{HB}	126	188	B	
Vertical Section	Period	T_V	1092	1116	1080+A	T_{line}
	Active	T_{VD}	1080			
	Blanking	T_{VB}	12	36	A	

Note1 : The above is as optimized setting

Note2 : DE mode only

Note3 : The maximum clock frequency = $[(1920 + B)*(1080+A)*60] < 149\text{MHz}$

Note4 : Clock frequency number is for reference, real setting value refer to EDID (Clock frequency 141.4 MHz)

Note5 : Horizontal related parameters must be constant without variation(H_Sync_Width, H_Front_Porch and H_Back_Porch must be constant on each scanline).

Note6 : On vertical blank area, H_Sync_Width and H_Total must be same as on the V_Active area.

Note7 : Vertical related parameters must be constant without variation.(V_Sync_Width, V_Front_Porch and V_Back_Porch must be constant on each video field).

Note8 : In DE only mode, the DE timings also must be constant without variation(H/V timing requirements are as same as previous. Blank timing must also be constant).

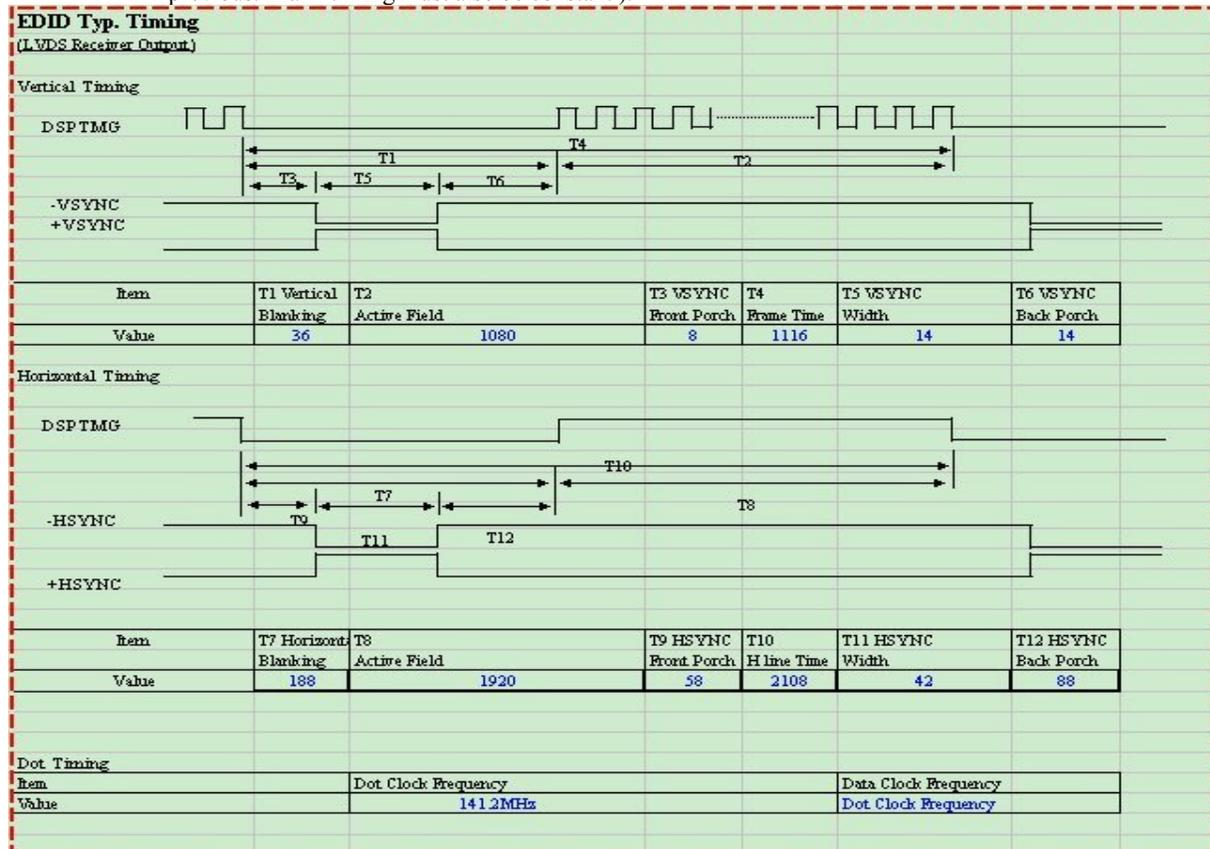

5.4.2 Timing Diagram

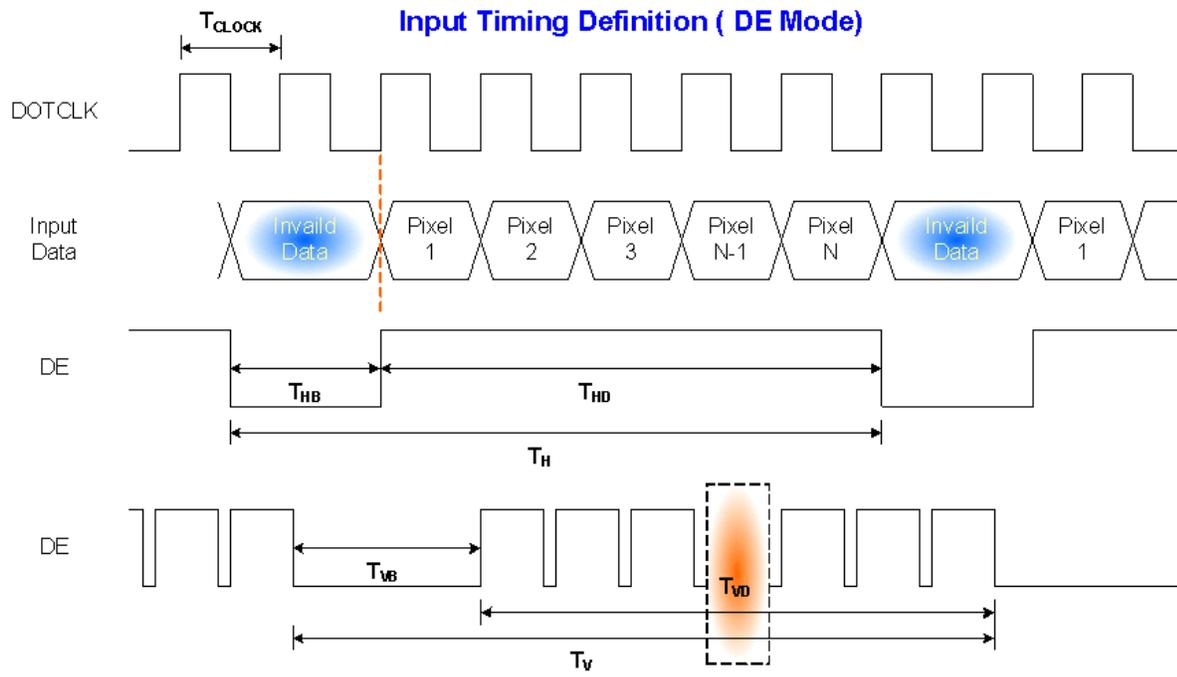

5.5 Power ON/OFF Sequence

VDD power and backlight on/off sequence is as below. Interface signals are also shown in the chart. Signals from any system shall be Hi-Z state or low level when VDD is off.

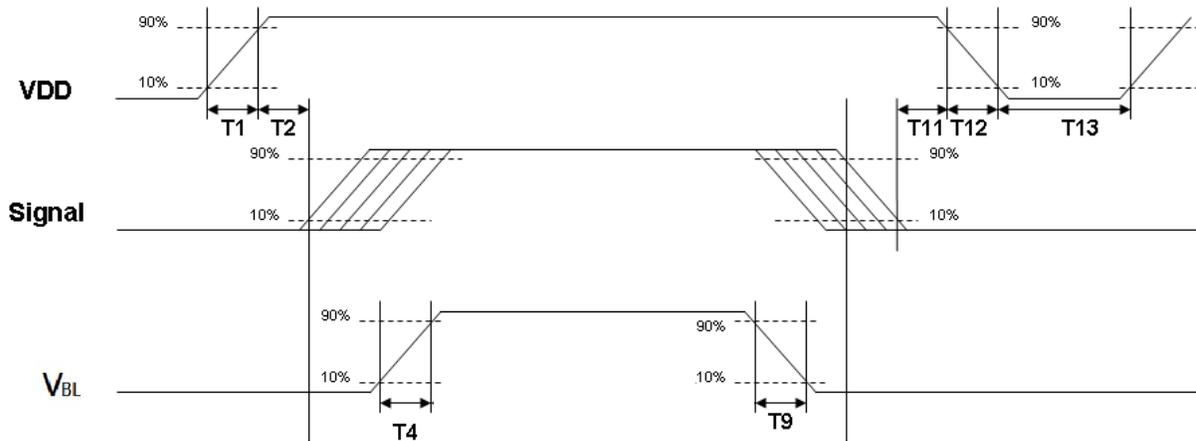

Power ON/OFF sequence timing

Parameter	Value			Units
	Min.	Typ.	Max.	
T1	0.1	-	10	[ms]
T2	200	-	-	[ms]
T3	50	-	-	[ms]
T4	0.5	-	10	[ms]
T5	10	-	-	[ms]
T6	10	-	-	[ms]
T7	10	-	-	[ms]
T8	10	-	-	[ms]
T9	0.5	-	10	[ms]
T10	50	-	-	[ms]
T11	10	-	-	[ms]
T12	-	-	10	[ms]
T13	1000	-	-	[ms]

The above on/off sequence should be applied to avoid abnormal function in the display. Please make sure to turn off the power when you plug the cable into the input connector or pull the cable out of the connector.

6. Connector & Pin Assignment

Physical interface is described as for the connector on module. These connectors are capable of accommodating the following signals and will be following components.

6.1 TFT LCD Module

6.1.1 Connector(CN1)

Connector Name / Designation	Interface Connector / Interface card
Manufacturer	Hirose
Type Part Number	DF19K-30P-1H (54)
Mating Housing Part Number	DF19G-30S-1C(05) DF19A-2830SCFA(41)

6.1.2 Pin Assignment(CN1)

Pin#	Signal Name	Pin#	Signal Name
1	RxOIN0-	2	RxOIN0+
3	RxOIN1-	4	RxOIN1+
5	RxOIN2-	6	RxOIN2+
7	GND	8	RxOCLKIN-
9	RxOCLKN+	10	RxOIN3-
11	RxOIN3+	12	RxEIN0-
13	RxEIN0+	14	GND
15	RxEIN1-	16	RxEIN1+
17	GND	18	RxEIN2-
19	RxEIN2+	20	RxECLKIN-
21	RxECLKIN+	22	RxEIN3-
23	RxEIN3+	24	GND
25	AGBSEN	26	VDD
27	VDD	28	SCL
29	SDA	30	GND

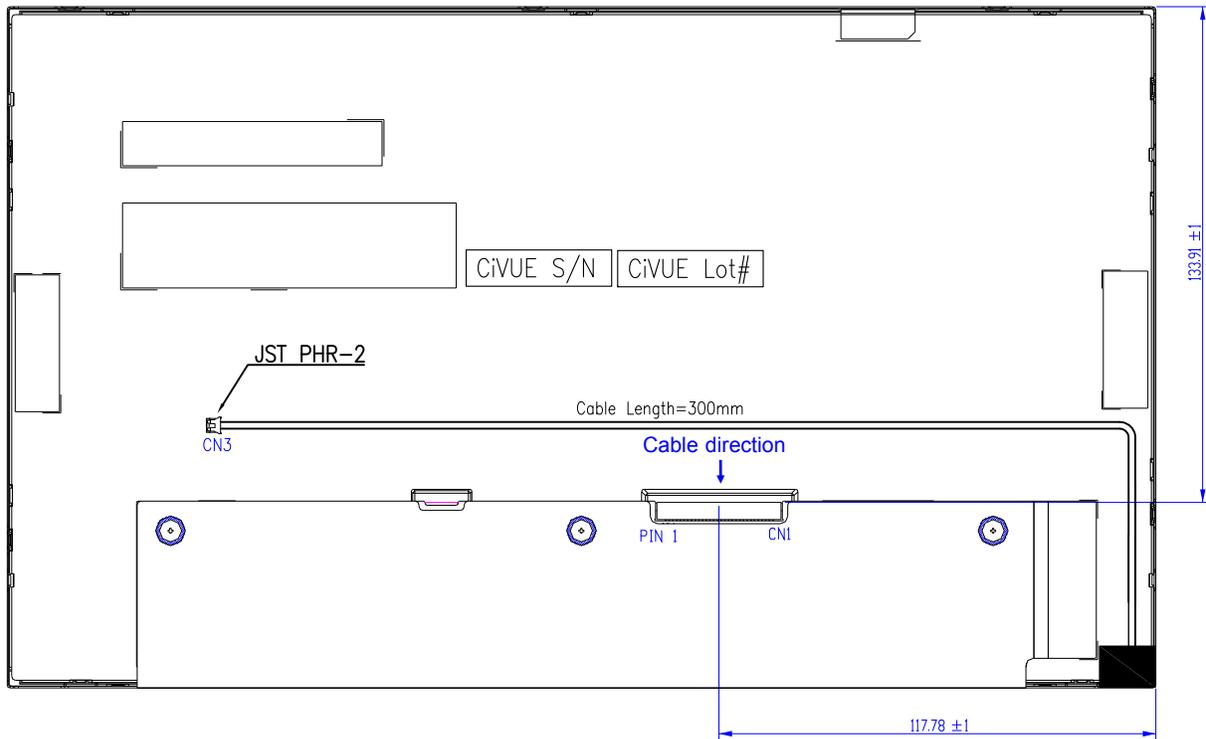

6.2 Backlight Unit

Physical interface is described as for the connector on module. These connectors are capable of accommodating the following signals and will be following components.

6.2.1 Connector (CN3)

Connector Name / Designation	Backlight Connector
Manufacturer	JST
Type Part Number	PHR-2 or compatible
Mating Housing Part Number	S2B-PH-SM4-TB or compatible

6.2.2 Pin Assignment (CN3)

Pin	Symbol	Description	Remark
1	Power	Input Power	Red Color
2	GND	Ground	White Color

7. Panel Reliability Test

Items	Required Condition	Note
Temperature Humidity Bias	Ta= 40°C, 90%RH, 300h	Note 1,2
High Temperature Operation	Ta= 70°C , Dry, 300h	
Low Temperature Operation	Ta= 0°C, 300h	
High Temperature Storage	Ta= 70°C, Dry, 300h	
Low Temperature Storage	Ta= 0°C, 300h	
Thermal Shock Test	Ta=-20°C to 60°C, Duration at 30 min, 50 cycles	
Vibration test(non-operation)	1.5G, (10~200Hz~10, random), 30 mins/axis (X, Y, Z)	Note 1,2
Shock Test(non-operation)	50G,20ms,Half-sine wave,(±X, ±Y, ±Z)	
ESD	Contact Discharge: ±8 KV, 150pF(330Ω) 1sec, 8Points, 25times/point Air Discharge: ±15 KV, 150pF(330Ω) 1sec, 8Points, 25times/point	Note 1

Note 1: According to EN 61000-4-2 , ESD class B: Some performance degradation allowed.
Self-recoverable. No data lost, No hardware failures.

Note 2:

- Water condensation is not allowed for each test items.
- Each test is done by new TFT-LCD module. Don't use the same TFT-LCD module repeatedly for reliability test.
- The reliability test is performed only to examine the TFT-LCD module capability.
- To inspect TFT-LCD module after reliability test, please store it at room temperature and room humidity for 24 hours at least in advance.
- No function failure occurs. Mura shall be ignored after high temperature reliability test

8. Package

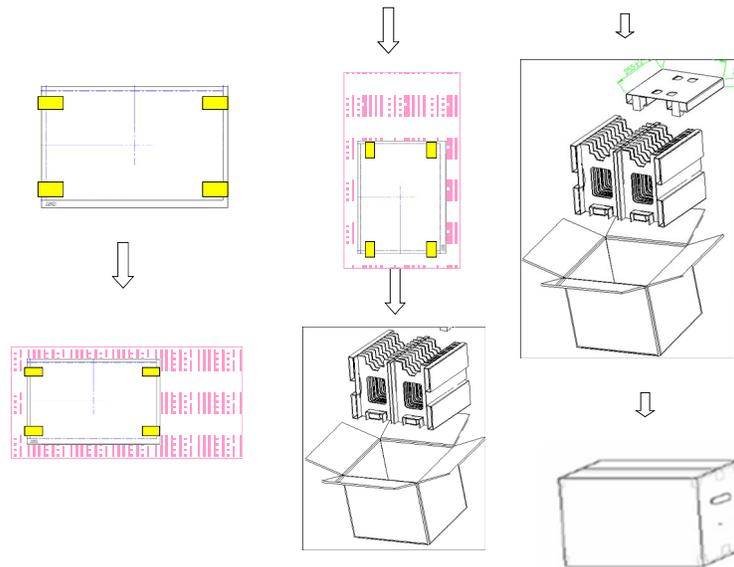

Max capacity : 20 TFT-LCD module per carton

Max weight: 10.5 kg per carton

Outside dimension of carton: 480mm(L)*275mm(W)*450mm(H)

Pallet size : 1150 mm * 910 mm * 132mm

Company Confidential

CIVUE OPTOTECH INC.

4F-2, No. 609, Sec. 1, Wanshou Road

Guishan Dist.Taoyuan City 333, Taiwan

Phone: +886-2-8200-6060

Fax: +886-2-8200-6161

Email: sales@civueopto.com

Copyright © 2017 CiVUE Optotech Inc. All rights reserves.
CiVUE is a registered trademark of CiVUE Optotech Inc.