

# Datasheet

## **LG Display** **LP125WF2-SPB2**

HD-10-137

The information contained in this document has been carefully researched and is, to the best of our knowledge, accurate. However, we assume no liability for any product failures or damages, immediate or consequential, resulting from the use of the information provided herein. Our products are not intended for use in systems in which failures of product could result in personal injury. All trademarks mentioned herein are property of their respective owners. All specifications are subject to change without notice.

---

# SPECIFICATION FOR APPROVAL

- ( ) Preliminary Specification
- ( ◆ ) Final Specification

Title	12.5" FHD TFT LCD
-------	-------------------

Customer	
MODEL	

SUPPLIER	LG Display Co., Ltd.
*MODEL	LP125WF2
Suffix	SPB2

\*When you obtain standard approval,  
please use the above model name without suffix

APPROVED BY	SIGNATURE
/	_____
/	_____
/	_____

APPROVED BY	SIGNATURE
_____	_____
<b>REVIEWED BY</b>	_____
<b>PREPARED BY</b>	_____

Please return 1 copy for your confirmation with your signature and comments.

**Products Engineering Dept.  
LG Display Co., Ltd**

## Product Specification

Contents

No	ITEM	Page
	COVER	1
	CONTENTS	2
	RECORD OF REVISIONS	3
1	GENERAL DESCRIPTION	4
2	ABSOLUTE MAXIMUM RATINGS	5
3	ELECTRICAL SPECIFICATIONS	
3-1	ELECTRICAL CHARACTERISTICS	6-7
3-2	INTERFACE CONNECTIONS	8
3-3	eDP SIGNAL TIMING SPECIFICATION	9
3-4	SIGNAL TIMING SPECIFICATIONS	10
3-5	SIGNAL TIMING WAVEFORMS	10
3-6	COLOR INPUT DATA REFERENCE	11
3-7	POWER SEQUENCE	12
4	OPTICAL SPECIFICATIONS	13-15
5	MECHANICAL CHARACTERISTICS	16-18
6	RELIABILITY	19
7	INTERNATIONAL STANDARDS	
7-1	SAFETY	20
7-2	EMC	20
7-3	Environment	20
8	PACKING	
8-1	DESIGNATION OF LOT MARK	21
8-2	PACKING FORM	21
8-3	Label Description	22
9	PRECAUTIONS	23-24
A	APPENDIX. Enhanced Extended Display Identification Data	25-27



## 1. General Description

The LP125WF2 is a Color Active Matrix Liquid Crystal Display with an integral LED backlight system and Touch Screen Panel. The matrix employs a-Si Thin Film Transistor as the active element. It is a transmissive type display operating in the normally black mode. This TFT-LCD has 12.5 inches diagonally measured active display area with Full HD resolution (1920 horizontal by 1080 vertical pixel array). Each pixel is divided into Red, Green and Blue sub-pixels or dots which are arranged in vertical stripes. Gray scale or the brightness of the sub-pixel color is determined with a 6-bit gray scale signal for each dot, thus, presenting a palette of more than 262,144 colors. The LP125WF2 has been designed to apply the interface method that enables low power, high speed, low EMI. The LP125WF2 is intended to support applications where thin thickness, low power are critical factors and graphic displays are important. In combination with the vertical arrangement of the sub-pixels, the LP125WF2 characteristics provide an excellent flat display. LP125WF2 is the 'Touch total solution' model. It means it includes LCM & TSP all. (TSP is assembled by a 'Direct Bonding' method)

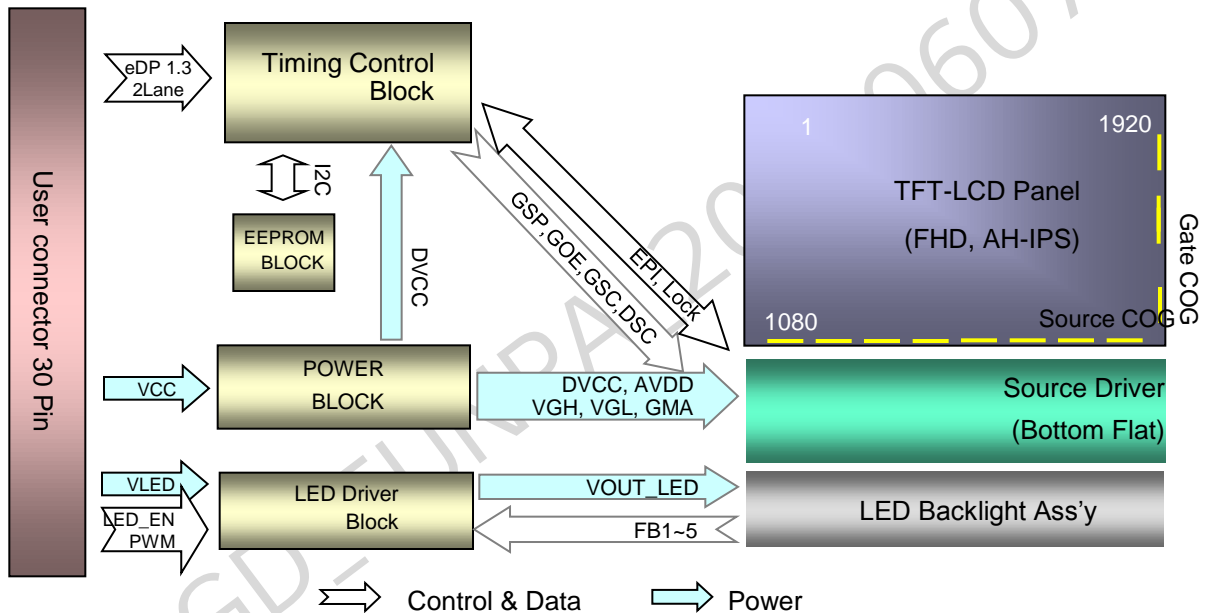

## General Features

Active Screen Size	12.5 inches diagonal
Outline Dimension	290.5(H, typ) × 170.7(V, typ) × 2.85(D,max) [mm]
Pixel Pitch	0.144mm x 0.144mm (176ppi)
Pixel Format	1920 horiz. By 1080 vert. Pixels RGB strip arrangement
Color Depth	6-bit, 262,144 colors
Luminance, White	400 cd/m <sup>2</sup>
Power Consumption	Total 5.0 W(Typ.) Logic : 1.1 W (Typ. @ Mosaic), B/L : 3.9 W (Typ. @ VLED 12V)
Weight	230g (Max.)
Display Operating Mode	Transmissive mode, normally black
Surface Treatment	Anti-Glare treatment of the front Polarizer
RoHS Compliance	Yes
BFR / PVC / As Free	Yes for all

## 2. Absolute Maximum Ratings

The following are maximum values which, if exceeded, may cause faulty operation or damage to the unit.

**Table 1. ABSOLUTE MAXIMUM RATINGS**

Parameter	Symbol	Values		Units	Notes
		Min	Max		
Power Input Voltage	VCC	-0.3	4.0	Vdc	at 25 ± 5°C
Operating Temperature	TOP	0	50	°C	1, 2
Storage Temperature	HST	-20	60	°C	1
Operating Ambient Humidity	HoP	10	90	%RH	1
Storage Humidity	HST	10	90	%RH	1

Note : 1. Temperature and relative humidity range are shown in the figure below.

Wet bulb temperature should be 39°C Max, and no condensation of water.

2. LCD Surface Temperature Spec :

Panel surface temperature should be under 60 degrees operating at 50 degrees / 2hrs

3. Storage Condition is guaranteed under packing condition.

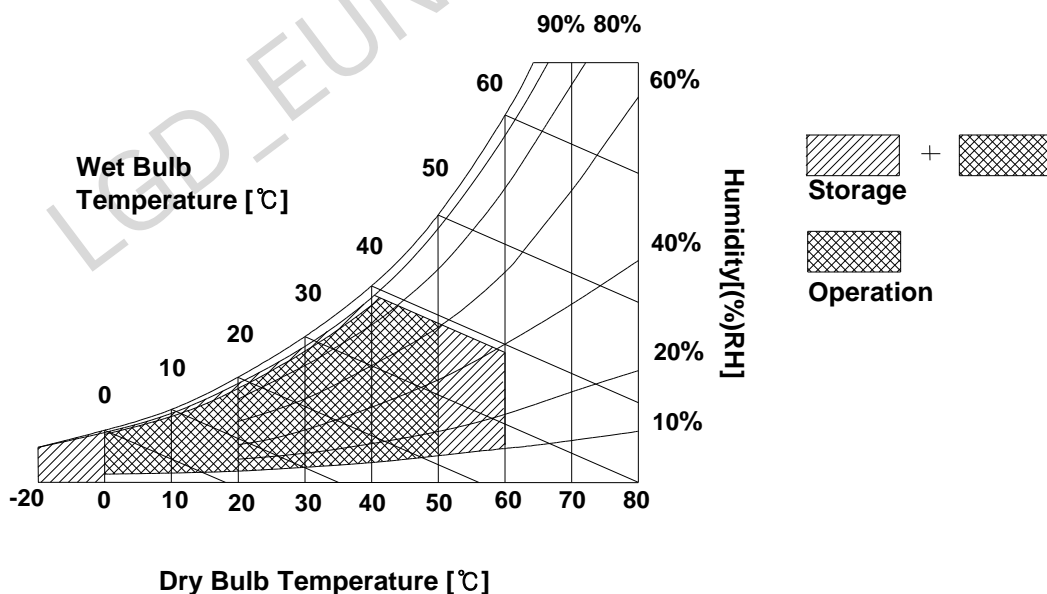

## Product Specification

### 3. Electrical Specifications

#### 3-1. Electrical Characteristics

The LP125WF2 requires two power inputs. The first logic is employed to power the LCD electronics and to drive the TFT array and liquid crystal. The second backlight is the input about LED BL with LED Driver.

**Table 2. ELECTRICAL CHARACTERISTICS**

Parameter	Symbol	Values			Unit	Notes	
		Min	Typ	Max			
LOGIC :							
Power Supply Input Voltage	V <sub>CC</sub>	3.0	3.3	3.6	V	1	
Power Supply Input Current	Mosaic	I <sub>CC</sub>	-	325	375	mA	2
	Red	I <sub>CC</sub>	-	395	453	mA	2
	Sub-v Line	I <sub>CC</sub>	-	530	610	mA	2
Power Consumption	P <sub>CC</sub>	-	1.1	1.2	W	2	
Power Supply Inrush Current	I <sub>CC_P</sub>	-	-	1500	mA	3	
eDP Impedance	Z <sub>LVDS</sub>	90	100	110	Ω	4	
BACKLIGHT : ( with LED Driver)							
LED Power Input Voltage	V <sub>LED</sub>	5.0	12.0	21.0	V	5	
LED Power Input Current	I <sub>LED</sub>	-	325	335	mA	6	
LED Power Consumption	P <sub>LED</sub>	-	3.9	4.0	W	6	
LED Power Inrush Current	I <sub>LED_P</sub>	-	-	1500	mA	7	
PWM Duty Ratio		1	-	100	%	8	
PWM Jitter	-	0	-	0.2	%	9	
PWM Impedance	Z <sub>PWM</sub>	20	40	60	kΩ		
PWM Frequency	F <sub>PWM</sub>	200	-	1000	Hz	10	
PWM High Level Voltage	V <sub>PWM_H</sub>	2.2	-	5.3	V		
PWM Low Level Voltage	V <sub>PWM_L</sub>	0	-	0.6	V		
LED_EN Impedance	Z <sub>PWM</sub>	20	40	60	kΩ		
LED_EN High Voltage	V <sub>LED_EN_H</sub>	2.2	-	5.3	V		
LED_EN Low Voltage	V <sub>LED_EN_L</sub>	0	-	0.6	V		
Life Time		12,000	-	-	Hrs	11	

Product Specification

Note)

1. The measuring position is the connector of LCM and the test conditions are under 25 °C,  $f_v = 60\text{Hz}$ , Black pattern.

2. The specified  $I_{cc}$  current and power consumption are under the  $V_{cc} = 3.3\text{V}$ , 25 °C,  $f_v = 60\text{Hz}$  condition and Mosaic pattern.

2-1. Max Input current (@Sub-V line)

- $V_{cc} 3.0\text{V} : 610\text{mA}$
- $V_{cc} 3.3\text{V} : 680\text{mA}$

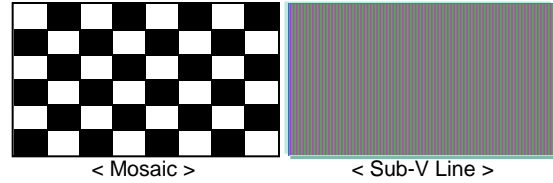

3. This Spec. is the max load condition for the cable impedance designing.

4. The below figures are the measuring  $V_{cc}$  condition and the  $V_{cc}$  control block LGD used.

The  $V_{cc}$  condition is same as the minimum of T1 at Power on sequence.

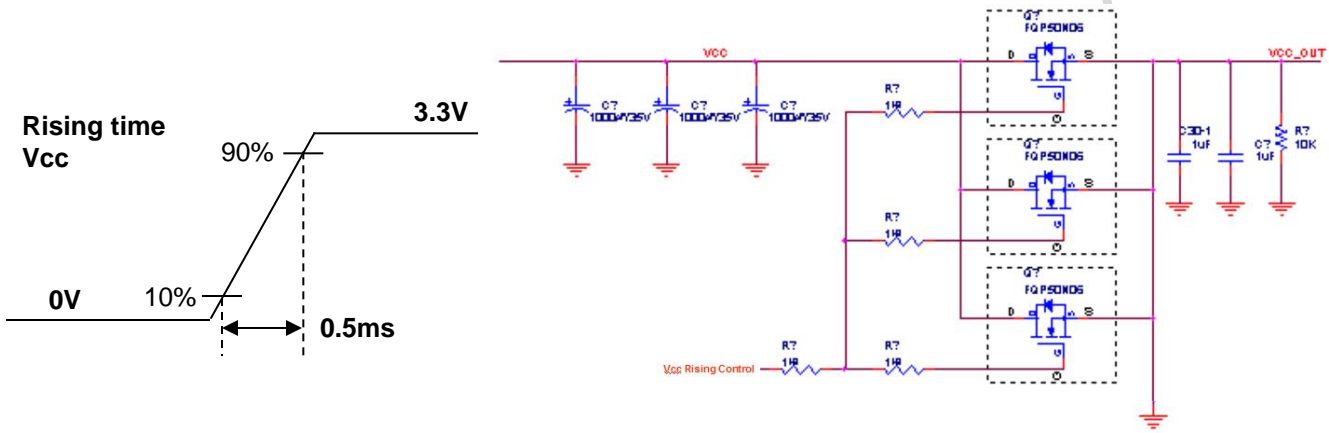

5. This impedance value is needed for proper display and measured form eDP Tx to the mating connector.

6. The measuring position is the connector of LCM and the test conditions are under 25 °C.

7. The current and power consumption with LED Driver are under the  $V_{LED} = 12.0\text{V}$ , 25 °C, Dimming of Max luminance and White pattern with the normal frame frequency operated(60Hz).

8. The below figures are the measuring  $V_{LED}$  condition

and the  $V_{LED}$  control block LGD used.

$V_{LED}$  control block is same with  $V_{cc}$  control block.

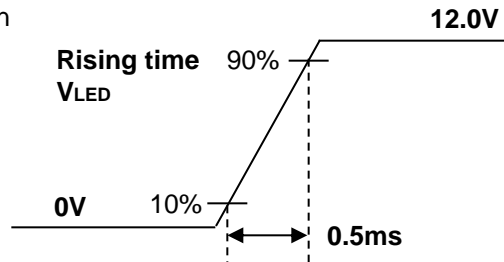

9. The operation of LED Driver below minimum dimming ratio may cause flickering or reliability issue.

10. If Jitter of PWM is bigger than maximum, it may induce flickering.

11. This Spec. is not effective at 100% dimming ratio as an exception because it has DC level equivalent to 0Hz. In spite of acceptable range as defined, the PWM Frequency should be fixed and stable for more consistent brightness control at any specific level desired.

12. The life time is determined as the time at which brightness of LCD is 50% compare to that of minimum value specified in table 7. under general user condition.



## Product Specification

### 3-2. Interface Connections

This LCD employs two interface connections, a 40 pin connector used for the module electronics interface and the other connector used for the integral backlight system.

**Table 3. MODULE CONNECTOR PIN CONFIGURATION (CN1)**

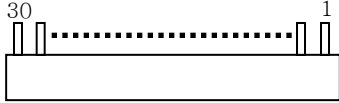
Pin	Symbol	Description	Notes
1	NC	No Connection (Reserved for LGD)	<b>[Interface Chip]</b> 1. LCD : Parade, DP643 (LCD Controller Including eDP Receiver). 2. System : TBD or equivalent * Pin to Pin compatible with eDP
2	GND	High Speed (Main Link) Ground	
3	ML1-	Complement Signal-Lane 1	
4	ML1+	True Signal-Main Lane 1	
5	GND	High Speed (Main Link) Ground	
6	ML0-	Complement Signal-Lane 0	
7	ML0+	True Signal-Main Lane 0	
8	GND	High Speed (Main Link) Ground	
9	AUX+	True Signal-Auxiliary Channel	
10	AUX-	Complement Signal-Auxiliary Channel	
11	GND	High Speed (Main Link) Ground	<b>[Connector]</b> KN38-30S-0.5H, HIROSE  <b>[Connector pin arrangement]</b>  [LCD Module Rear View]
12	VCC	VCC for Module (3.3V)	
13	VCC	VCC for Module (3.3V)	
14	NC	No Connection (Reserved for LGD)	
15	GND	LCM Ground (Logic Ground)	
16	GND	LCM Ground (Logic Ground)	
17	HPD	HPD signal pin	
18	GND	LCM Ground (LED Backlight Ground)	
19	GND	LCM Ground (LED Backlight Ground)	
20	GND	LCM Ground (LED Backlight Ground)	
21	GND	LCM Ground (LED Backlight Ground)	* Pin for PVcom : #24, #25 PVcom Address : 01010000
22	LED_EN	LED Backlight On/Off	
23	PWM	System PWM Signal input for dimming	
24	NC	No Connection (Reserved for LGD)	
25	NC	No Connection (Reserved for LGD)	
26	VLED	LED Backlight Power 5V-21V	
27	VLED	LED Backlight Power 5V-21V	
28	VLED	LED Backlight Power 5V-21V	
29	VLED	LED Backlight Power 5V-21V	
30	NC	No Connection (Reserved for LGD)	

## Product Specification

### 3-3. eDP Signal Timing Specifications

#### 3-3-1. DC Specification

The VESA Display Port related AC specification is compliant with the VESA Display Port Standard v1.3

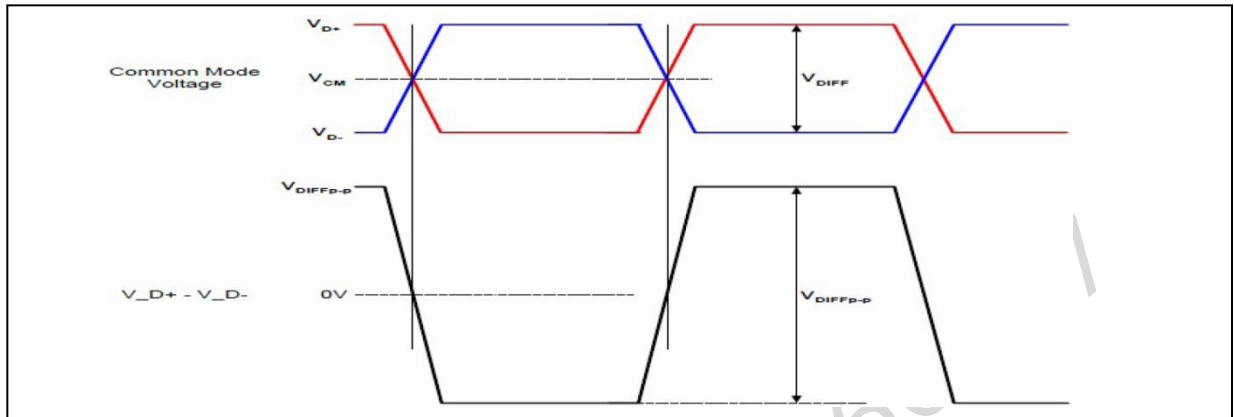

Description	Symbol	Min	Max	Unit	Notes
Differential peak-to-peak Input voltage	$V_{DIFF\ p-p}$	120	-	mV	For high bit rate
		40	-		For reduced bit rate
Rx DC common mode voltage	$V_{CM}$	0	2.0	V	-

#### 3-3-2. AC Specification

The VESA Display Port related AC specification is compliant with the VESA Display Port Standard v1.3

Description	Symbol	Min	Typ	Max	Unit	Notes
Unit Interval for high bit rate (2.7Gbps/lane)	UI_High_Rate	-	370	-	ps	Range is nominal $\pm 350$ ppm. DisplayPort Link Rx does not require local crystal for link clock generation
Unit Interval for high bit rate (1.62Gbps/lane)	UI_Low_Rate	-	617	-	ps	
Lane-to-Lane skew	$V_{Rx-SKEW-INTER\_PAIR}$	-	-	5200	ps	-
Lane intra-pair skew	$V_{Rx-SKEW-INTRA\_PAIR}$	-	-	100	ps	For high bit rate
		-	-	300	ps	For reduced bit rate

### 3-4. Signal Timing Specifications

This is the signal timing required at the input of the User connector. All of the interface signal timing should be satisfied with the following specifications and specifications of eDP Tx/Rx for its proper operation.

**Table 4. TIMING TABLE**

ITEM	Symbol	Min	Typ	Max	Unit	Note
DCLK	Frequency	$f_{CLK}$	-	138.46	-	MHz
Hsync	Period	$t_{HP}$	2090	2106	2122	tCLK
	Width	$t_{WH}$	28	32	36	
	Width-Active	$t_{WHA}$	1920	1920	1920	
Vsync	Period	$t_{VP}$	1090	1095	1100	tHP
	Width	$t_{WV}$	3	5	7	
	Width-Active	$t_{WVA}$	1080	1080	1080	
Data Enable	Horizontal back porch	$t_{HBP}$	102	106	110	tCLK
	Horizontal front porch	$t_{HFP}$	40	48	56	
	Vertical back porch	$t_{VBP}$	5	7	9	tHP
	Vertical front porch	$t_{VFP}$	2	3	4	

Appendix) all reliabilities are specified for timing specification based on refresh rate of 60Hz. However, LP125WF2 has a good actual performance even at lower refresh rate (e.g. 40Hz or 50Hz) for power saving mode, whereas LP125WF2 is secured only for function under lower refresh rate. 60Hz at Normal mode, 50Hz, 40Hz at Power save mode. Don't care Flicker level (power save mode).

### 3-5. Signal Timing Waveforms

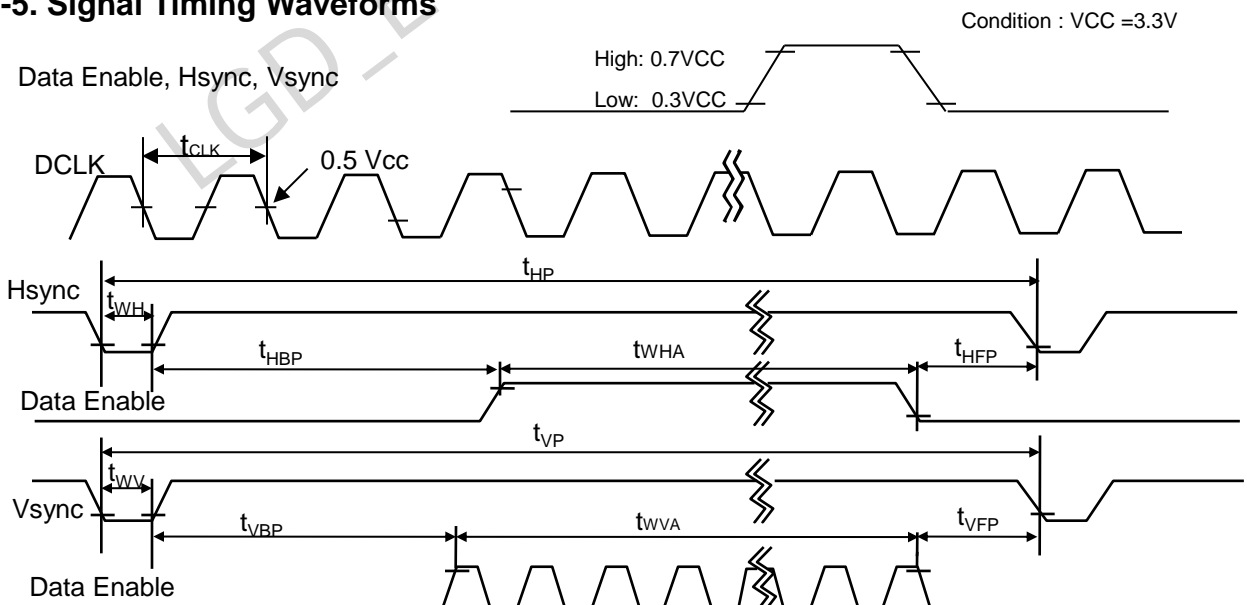

## Product Specification

### 3-6. Color Input Data Reference

The brightness of each primary color (red, green and blue) is based on the 6-bit gray scale data input for the color ; the higher the binary input, the brighter the color. The table below provides a reference for color versus data input.

Table 5. COLOR DATA REFERENCE

Color		Input Color Data																	
		RED						GREEN						BLUE					
		MSB		R3		LSB		MSB		G3		LSB		MSB		LSB			
		R5	R4	R3	R2	R1	R0	G5	G4	G3	G2	G1	G0	B5	B4	B3	B2	B1	B0
Basic Color	Black	0	0	0	0	0	0	0	0	0	0	0	0	0	0	0	0	0	0
	Red	1	1	1	1	1	1	0	0	0	0	0	0	0	0	0	0	0	0
	Green	0	0	0	0	0	0	1	1	1	1	1	1	0	0	0	0	0	0
	Blue	0	0	0	0	0	0	0	0	0	0	0	0	1	1	1	1	1	1
	Cyan	0	0	0	0	0	0	1	1	1	1	1	1	1	1	1	1	1	1
	Magenta	1	1	1	1	1	1	0	0	0	0	0	0	1	1	1	1	1	1
	Yellow	1	1	1	1	1	1	1	1	1	1	1	1	0	0	0	0	0	0
	White	1	1	1	1	1	1	1	1	1	1	1	1	1	1	1	1	1	1
RED	RED (00)	0	0	0	0	0	0	0	0	0	0	0	0	0	0	0	0	0	0
	RED (01)	0	0	0	0	0	1	0	0	0	0	0	0	0	0	0	0	0	0
	...	...						...						...					
	RED (62)	1	1	1	1	1	0	0	0	0	0	0	0	0	0	0	0	0	0
	RED (63)	1	1	1	1	1	1	0	0	0	0	0	0	0	0	0	0	0	0
GREEN	GREEN (00)	0	0	0	0	0	0	0	0	0	0	0	0	0	0	0	0	0	0
	GREEN (01)	0	0	0	0	0	0	0	0	0	0	0	1	0	0	0	0	0	0
	...	...						...						...					
	GREEN (62)	0	0	0	0	0	0	1	1	1	1	1	0	0	0	0	0	0	0
	GREEN (63)	0	0	0	0	0	0	1	1	1	1	1	1	0	0	0	0	0	0
BLUE	BLUE (00)	0	0	0	0	0	0	0	0	0	0	0	0	0	0	0	0	0	0
	BLUE (01)	0	0	0	0	0	0	0	0	0	0	0	0	0	0	0	0	0	1
	...	...						...						...					
	BLUE (62)	0	0	0	0	0	0	0	0	0	0	0	0	1	1	1	1	1	0
	BLUE (63)	0	0	0	0	0	0	0	0	0	0	0	0	1	1	1	1	1	1

Product Specification

**3-7. Power Sequence**

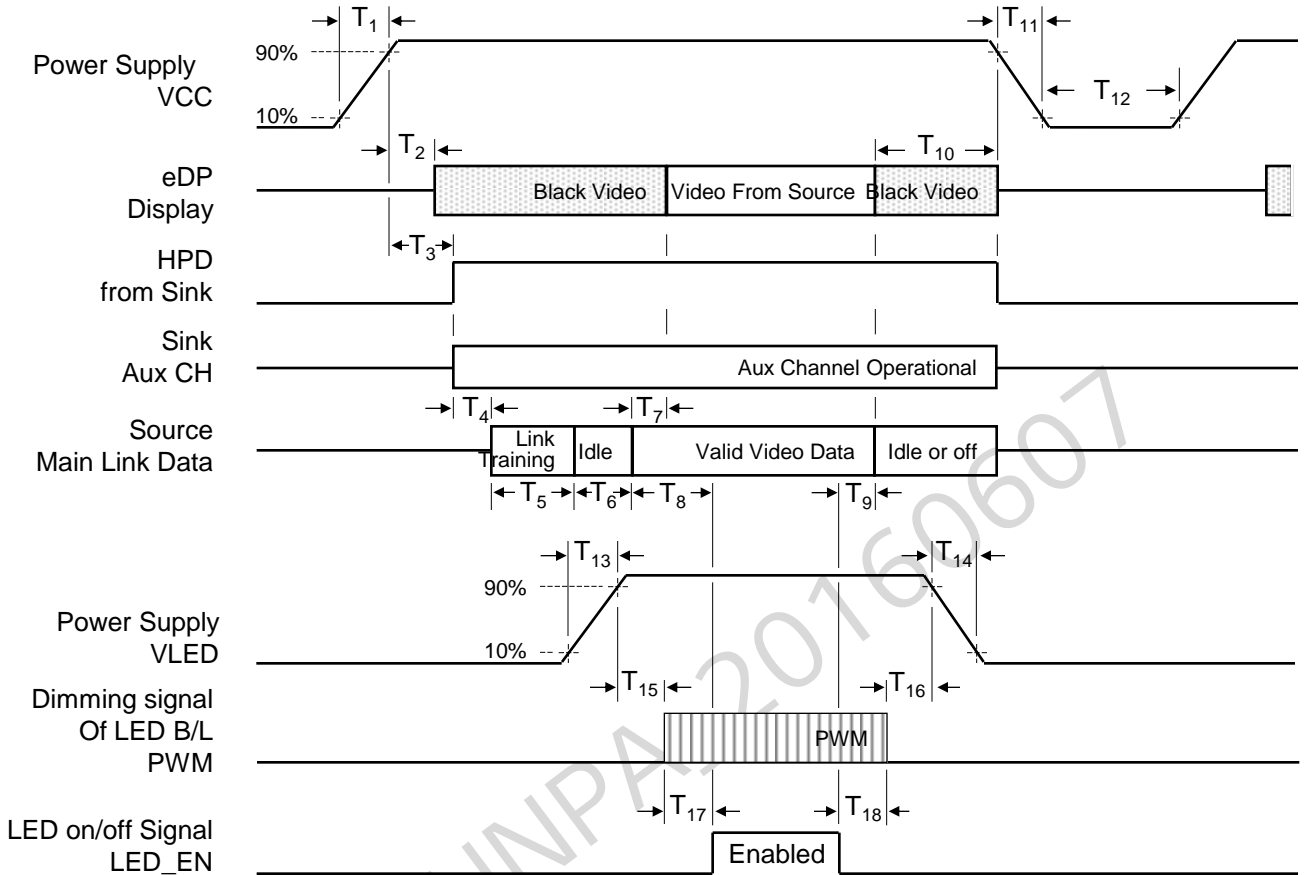

Table 6. POWER SEQUENCE TABLE

Timing	Required By	Limits		Units	Notes
		Min	Max		
T <sub>1</sub>	Source	0.5	10	ms	-
T <sub>2</sub>	Sink	0	200	ms	-
T <sub>3</sub>	Sink	0	200	ms	-
T <sub>4</sub>	Source	-	-	ms	-
T <sub>5</sub>	Source	-	-	ms	-
T <sub>6</sub>	Source	-	-	ms	-
T <sub>7</sub>	Sink	0	50	ms	-
T <sub>8</sub>	Source	-	-	ms	LGD recommend Min 200ms
T <sub>9</sub>	Source	-	-	ms	-

Timing	Required By	Limits		Units	Notes
		Min	Max		
T <sub>10</sub>	Source	0	500	ms	-
T <sub>11</sub>	Source	-	10	ms	-
T <sub>12</sub>	Source	150	-	ms	VESA recommend Min 500ms
T <sub>13</sub>	Source	0.5	10	ms	-
T <sub>14</sub>	Source	0	5000	ms	-
T <sub>15</sub>	Source	0	-	ms	-
T <sub>16</sub>	Source	0	-	ms	-
T <sub>17</sub>	Source	0	-	ms	-
T <sub>18</sub>	Source	0	-	ms	-

- Note) 1. Do not insert the mating cable when system turn on.  
 2. Valid Data have to meet "3-3. eDP Signal Timing Specifications"  
 3. Video Signal, LED\_EN and PWM need to be on pull-down condition on invalid status.  
 4. LGD recommend the rising sequence of VLED after the Vcc and valid status of Video Signal turn on.

## 4. Optical Specification

Optical characteristics are determined after the unit has been 'ON' and stable for approximately 20 minutes in a dark environment at 25°C. The values specified are at an approximate distance 50cm from the LCD surface at a viewing angle of  $\Phi$  and  $\Theta$  equal to 0°.

FIG. 1 presents additional information concerning the measurement equipment and method.

**FIG. 1 Optical Characteristic Measurement Equipment and Method**

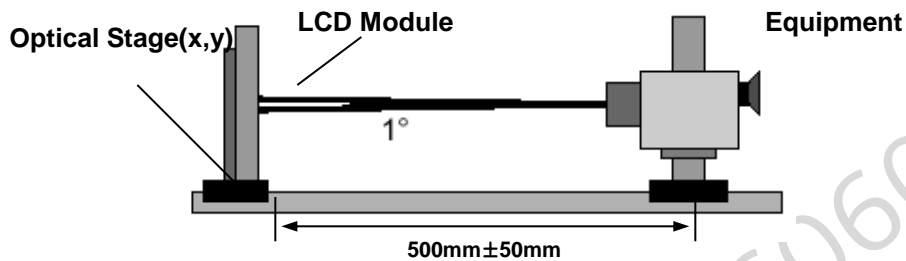

**Table 7. OPTICAL CHARACTERISTICS**

Ta=25°C, VCC=3.3V, fv=60Hz, fCLK= 138.46 MHz

Parameter	Symbol	Values			Units	Notes
		Min	Typ	Max		
Contrast Ratio	CR	600	700	-		1
Surface Luminance, white	L <sub>WH</sub>	320	400	-	cd/m <sup>2</sup>	2
Luminance Variation	$\delta_{\text{WHITE}(5p)}$	-		1.25	-	3
	$\delta_{\text{WHITE}(13p)}$	-	1.4	1.6		
Response Time (W to B)	Tr <sub>R</sub> + Tr <sub>D</sub>	-	35	50	ms	4
Color Coordinates						
RED	RX	0.574	0.604	0.634		
	RY	0.321	0.351	0.381		
GREEN	GX	0.305	0.335	0.365		
	GY	0.528	0.558	0.588		
BLUE	BX	0.118	0.148	0.178		
	BY	0.083	0.113	0.143		
WHITE	WX	0.283	0.313	0.343		
	WY	0.299	0.329	0.359		
Viewing Angle						
x axis, right( $\Phi=0^\circ$ )	$\Theta_r$	80	-	-	degree	5  CR ≥ 10
x axis, left ( $\Phi=180^\circ$ )	$\Theta_l$	80	-	-	degree	
y axis, up ( $\Phi=90^\circ$ )	$\Theta_u$	80	-	-	degree	
y axis, down ( $\Phi=270^\circ$ )	$\Theta_d$	80	-	-	degree	
Gray Scale						6
Color Gamut	%	-	50	-		

## Product Specification

Note)

1. Contrast Ratio(CR) is defined mathematically as

$$\text{Contrast Ratio} = \frac{\text{Surface Luminance with all white pixels}}{\text{Surface Luminance with all black pixels}}$$

2. Surface luminance is the average of 5 point across the LCD surface 50cm from the surface with all pixels displaying white. For more information see FIG 1.

$$\text{LWH} = \text{Average}(L1, L2, \dots L5)$$

3. The variation in surface luminance, The panel total variation ( WHITE) is determined by measuring LN at each test position 1 through 13 and then defined as followed numerical formula.  
For more information see FIG 2.

$$\text{WHITE}_{5P} = \frac{\text{Maximum}(L1, L2, \dots L5)}{\text{Minimum}(L1, L2, \dots L5)}$$

$$\text{WHITE}_{13P} = \frac{\text{Maximum}(L1, L2, \dots L13)}{\text{Minimum}(L1, L2, \dots L13)}$$

4. Response time is the time required for the display to transition from white to black (rise time, TrR) and from black to white(Decay Time, TrD). For additional information see FIG 3.
5. Viewing angle is the angle at which the contrast ratio is greater than 10. The angles are determined for the horizontal or x axis and the vertical or y axis with respect to the z axis which is normal to the LCD surface. For more information see FIG 4.
6. Gray scale specification \* fV = 60Hz

Gray Level	Luminance [%] (Typ)
L0	0.16
L31	0.97
L63	4.26
L95	10.5
L127	19.8
L159	33.6
L191	52.1
L223	74.8
L255	100

FIG. 2 Luminance

<Measuring point for Average Luminance & measuring point for Luminance variation>

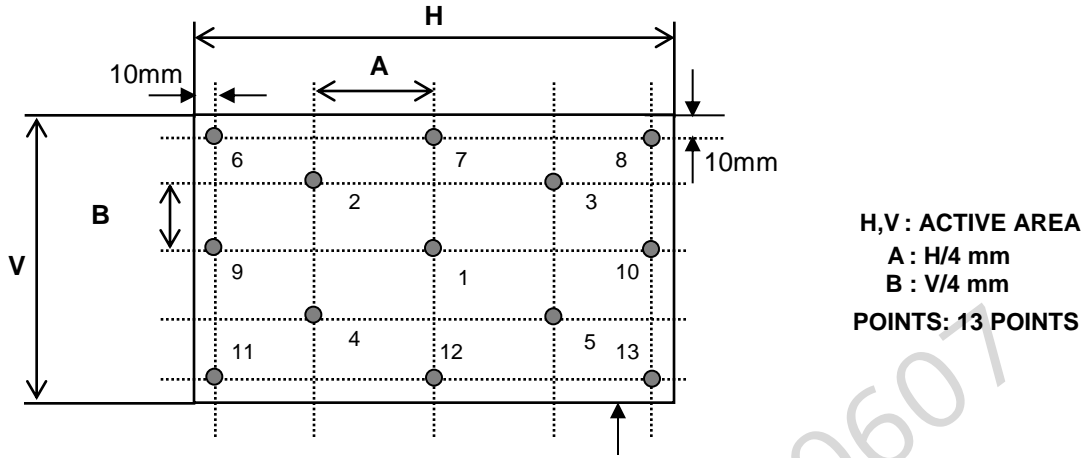

FIG. 3 Response Time

The response time is defined as the following figure and shall be measured by switching the input signal for "black" and "white".

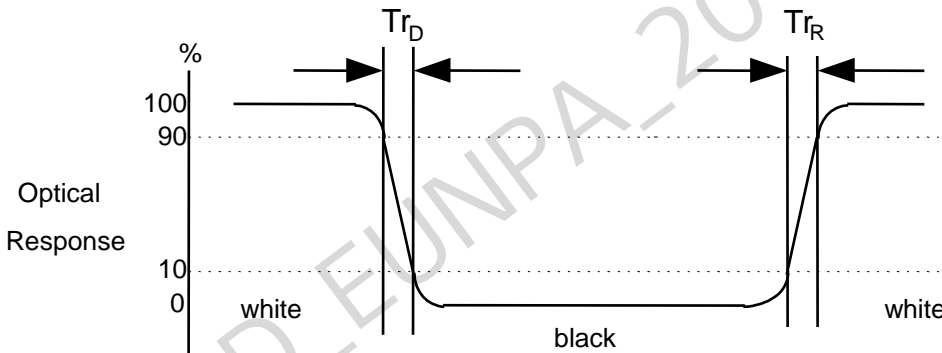
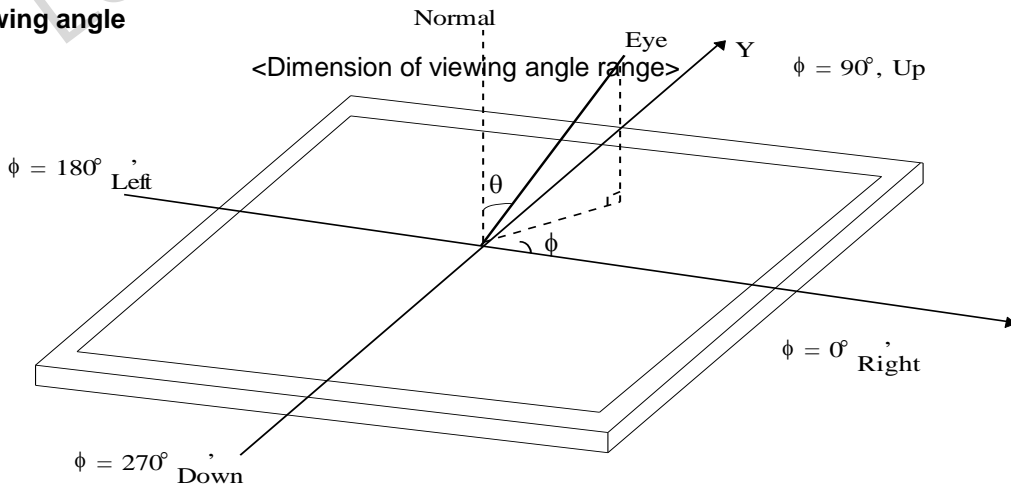

FIG. 4 Viewing angle





## Product Specification

## 5. Mechanical Characteristics

The contents provide general mechanical characteristics for the model LP125WF2. In addition the figures in the next page are detailed mechanical drawing of the LCD.

Outline Dimension	Horizontal	$290.5 \pm 0.5\text{mm}$
	Vertical	$170.7 \pm 0.5\text{mm}$
	Thickness	2.85mm (max)
Bezel Area	Horizontal	$279.60 \pm 0.5\text{mm}$
	Vertical	$158.94 \pm 0.5\text{mm}$
Active Display Area	Horizontal	$276.48 \pm 0.3\text{m}$
	Vertical	$155.52 \pm 0.3\text{mm}$
Weight	230g (Max.)	
Surface Treatment	Anti-Glare treatment of the front polarizer	

Product Specification

<FRONT VIEW>

Note) Unit:[mm], General tolerance:  $\pm 0.5\text{mm}$

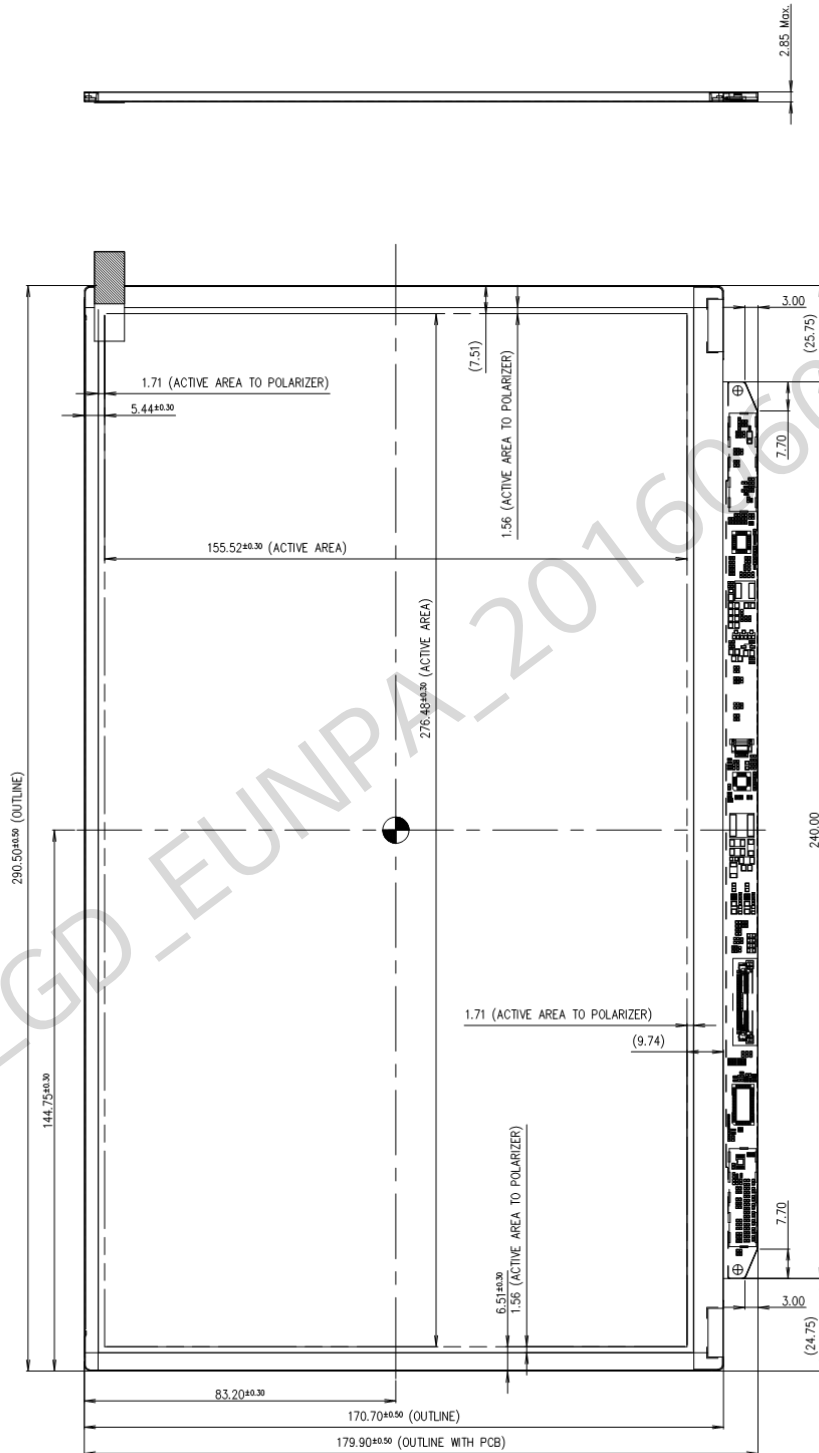

Product Specification

<REAR VIEW>

Note) Unit:[mm], General tolerance:  $\pm 0.5\text{mm}$   
LCD label must not be overlapped with metal frame.

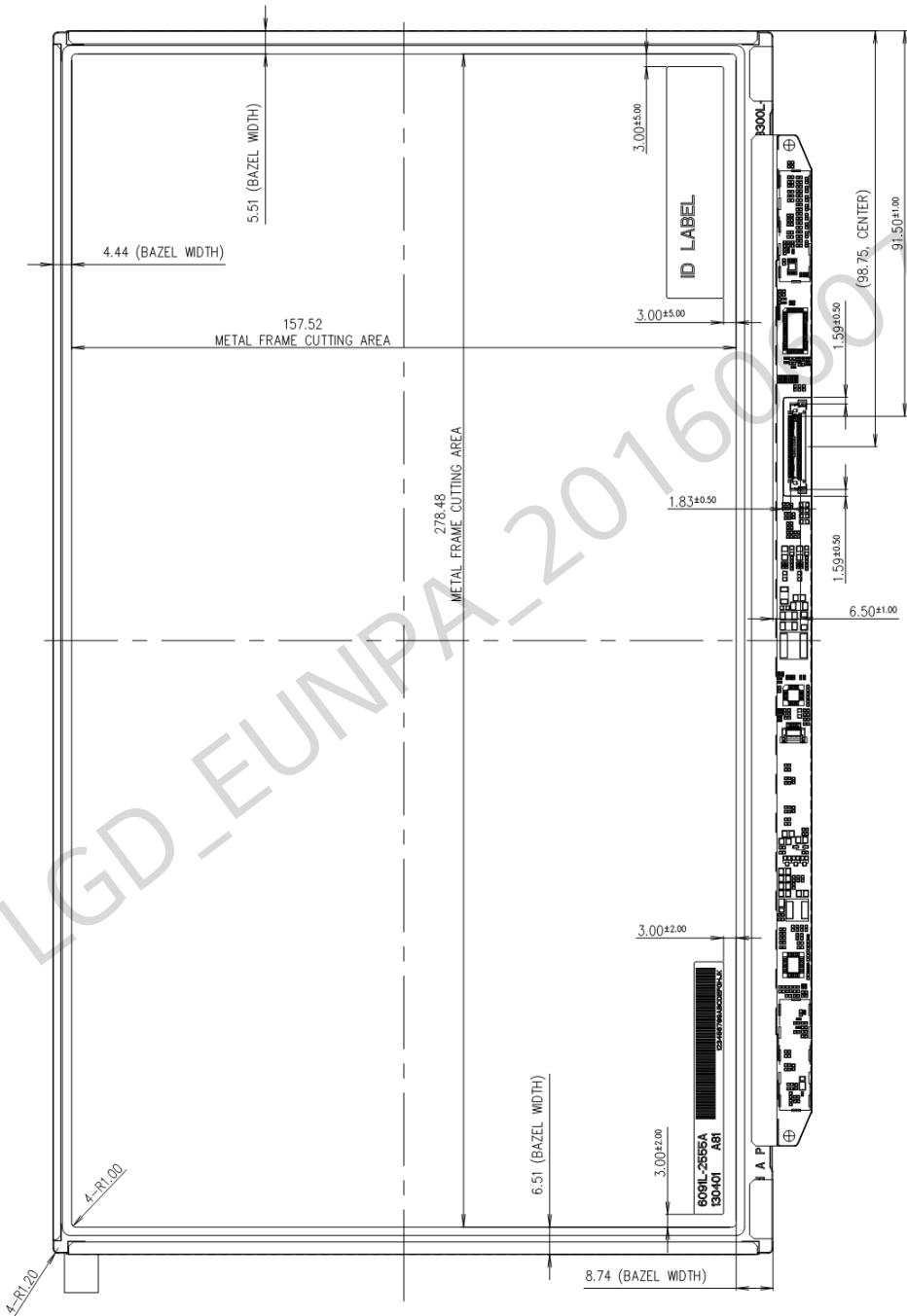

## Product Specification

## 6. Reliability

Environment test condition

No.	Test Item	Conditions
1	High temperature storage test	Ta= 60°C, 240h
2	Low temperature storage test	Ta= -20°C, 240h
3	High temperature operation test	Ta= 50°C, 50%RH, 240h
4	Low temperature operation test	Ta= 0°C, 240h
5	Vibration test (non-operating)	Random, 1.0Grms, 10 ~ 300Hz(PSD 0.0035) 3 axis, 30min/axis
6	Shock test (non-operating)	- No functional or cosmetic defects following a shock to all 6 sides delivering at least 180 G in a half sine pulse no longer than 2 ms to the display module - No functional defects following a shock delivering at least 200 g in a half sine pulse no longer than 2 ms to each of 6 sides. Each of the 6 sides will be shock tested with one each display, for a total of 6 displays
7	Altitude  operating storage / shipment	0 ~ 10,000 feet (3,048m) 24Hr 0 ~ 40,000 feet (12,192m) 24Hr

{ Result Evaluation Criteria }

There should be no change which might affect the practical display function when the display quality test is conducted under normal operating condition.

## 7. International Standards

### 7-1. Safety

- a) UL 60950-1, Underwriters Laboratories Inc.  
Information Technology Equipment - Safety - Part 1 : General Requirements.
- b) CAN/CSA-C22.2 No. 60950-1-07, Canadian Standards Association.  
Information Technology Equipment - Safety - Part 1 : General Requirements.
- c) EN 60950-1, European Committee for Electrotechnical Standardization (CENELEC).  
Information Technology Equipment - Safety - Part 1 : General Requirements.
- d) IEC 60950-1, The International Electrotechnical Commission (IEC).  
Information Technology Equipment - Safety - Part 1 : General Requirements

### 7-2. Environment

- a) RoHS, Directive 2011/65/EU of the European Parliament and of the council of 8 June 2011

LGD\_EUNPA\_20160607

## Product Specification

## 8. Packing

### 8-1. Designation of Lot Mark

a) Lot Mark

A	B	C	D	E	F	G	H	I	J	K	L	M
---	---	---	---	---	---	---	---	---	---	---	---	---

 A,B,C : SIZE(INCH)  
 E : MONTH

 D : YEAR  
 F ~ M : SERIAL NO.

Note

1. YEAR

Year	2011	2012	2013	2014	2015	2016	2017	2018	2019	2020
Mark	A	B	C	D	E	F	G	H	J	K

2. MONTH

Month	Jan	Feb	Mar	Apr	May	Jun	Jul	Aug	Sep	Oct	Nov	Dec
Mark	1	2	3	4	5	6	7	8	9	A	B	C

b) Location of Lot Mark

Serial No. is printed on the label. The label is attached to the backside of the LCD module.  
 This is subject to change without prior notice.

### 8-2. Packing Form

a) Package quantity in one box : 30pcs

b) Box Size : 478mm X 365mm X 244mm

### 8-3. Label Description

#### Model Name



LP125WF2 (SP)(B2) 8SSD10A09825L1SNXXXXXX



P/N:SD10A09825  
FRU:00HM745  
RoHS Verified

XXXXXXXXXXXXX XXX



**Lenovo CODE**

**LGD CODE**

#### LGD Code

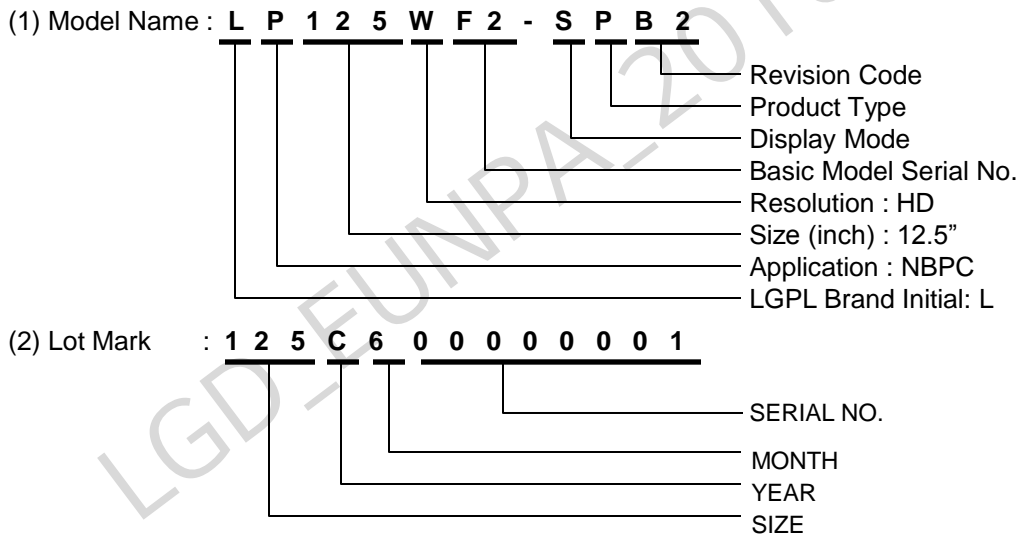

#### Lenovo Code

- 1)P/N : SD10A09825
- 2)FRU : 00HM745

## 9. PRECAUTIONS

Please pay attention to the followings when you use this TFT LCD module.

### 9-1. MOUNTING PRECAUTIONS

- (1) You must mount a module using holes arranged in four corners or four sides.
- (2) You should consider the mounting structure so that uneven force (ex. Twisted stress) is not applied to the module. And the case on which a module is mounted should have sufficient strength so that external force is not transmitted directly to the module.
- (3) Please attach the surface transparent protective plate to the surface in order to protect the polarizer. Transparent protective plate should have sufficient strength in order to resist external force.
- (4) You should adopt radiation structure to satisfy the temperature specification.
- (5) Acetic acid type and chlorine type materials for the cover case are not desirable because the former generates corrosive gas of attacking the polarizer at high temperature and the latter causes circuit break by electro-chemical reaction.
- (6) Do not touch, push or rub the exposed polarizers with glass, tweezers or anything harder than HB pencil lead. And please do not rub with dust clothes with chemical treatment. Do not touch the surface of polarizer for bare hand or greasy cloth. (Some cosmetics are detrimental to the polarizer.)
- (7) When the surface becomes dusty, please wipe gently with absorbent cotton or other soft materials like chamois soaks with petroleum benzene. Normal-hexane is recommended for cleaning the adhesives used to attach front / rear polarizers. Do not use acetone, toluene and alcohol because they cause chemical damage to the polarizer.
- (8) Wipe off saliva or water drops as soon as possible. Their long time contact with polarizer causes deformations and color fading.
- (9) Do not open the case because inside circuits do not have sufficient strength.
- (10) When handling the LCD module, it needs to handle with care not to give mechanical stress to the PCB and Mounting Hole area."

### 9-2. OPERATING PRECAUTIONS

- (1) The spike noise causes the mis-operation of circuits. It should be lower than following voltage :  
 $V = \pm 200\text{mV}$  (Over and under shoot voltage)
- (2) Response time depends on the temperature. (In lower temperature, it becomes longer.)
- (3) Brightness depends on the temperature. (In lower temperature, it becomes lower.)  
And in lower temperature, response time (required time that brightness is stable after turned on) becomes longer.
- (4) Be careful for condensation at sudden temperature change. Condensation makes damage to polarizer or electrical contacted parts. And after fading condensation, smear or spot will occur.
- (5) When fixed patterns are displayed for a long time, remnant image is likely to occur.
- (6) Module has high frequency circuits. Sufficient suppression to the electromagnetic interference shall be done by system manufacturers. Grounding and shielding methods may be important to minimized the interference.



### 9-3. ELECTROSTATIC DISCHARGE CONTROL

Since a module is composed of electronic circuits, it is not strong to electrostatic discharge. Make certain that treatment persons are connected to ground through wrist band etc. And don't touch interface pin directly.

### 9-4. PRECAUTIONS FOR STRONG LIGHT EXPOSURE

Strong light exposure causes degradation of polarizer and color filter.

### 9-5. STORAGE

When storing modules as spares for a long time, the following precautions are necessary.

- (1) Store them in a dark place. Do not expose the module to sunlight or fluorescent light. Keep the temperature between 5°C and 35°C at normal humidity.
- (2) The polarizer surface should not come in contact with any other object.  
It is recommended that they be stored in the container in which they were shipped.

### 9-6. HANDLING PRECAUTIONS FOR PROTECTION FILM

- (1) When the protection film is peeled off, static electricity is generated between the film and polarizer.  
This should be peeled off slowly and carefully by people who are electrically grounded and with well ion-blown equipment or in such a condition, etc.
- (2) The protection film is attached to the polarizer with a small amount of glue. If some stress is applied to rub the protection film against the polarizer during the time you peel off the film, the glue is apt to remain on the polarizer.  
Please carefully peel off the protection film without rubbing it against the polarizer.
- (3) When the module with protection film attached is stored for a long time, sometimes there remains a very small amount of glue still on the polarizer after the protection film is peeled off.
- (4) You can remove the glue easily. When the glue remains on the polarizer surface or its vestige is recognized, please wipe them off with absorbent cotton waste or other soft material like chamois soaked with normal-hexane.

### 9-7. THE LGD QA RESPONSIBILITY WILL BE AVOIDED IN CASE OF BELOW

- (1) When the customer attaches TSM(Touch Sensor Module) on LCM without Supplier's approval.
- (2) When the customer attaches cover glass on LCM without Supplier's approval.
- (3) When the LCMs were repaired by 3rd party without Supplier's approval.
- (4) When the LCMs were treated like Disassemble and Rework by the Customer and/or Customer's representatives without supplier's approval.

## Product Specification

**APPENDIX A. Enhanced Extended Display Identification Data (EEDID™) 1/3**
**EDID Data for Lenovo \_ ver. 1.0**

2013.10.08

	Byte (Dec)	Byte (Hex)	Field Name and Comments	Value (Hex)	Value (Bin)
<b>Header</b>	0	00	Header	00	00000000
	1	01	Header	FF	11111111
	2	02	Header	FF	11111111
	3	03	Header	FF	11111111
	4	04	Header	FF	11111111
	5	05	Header	FF	11111111
	6	06	Header	FF	11111111
<b>Vendor / Product EDID Version</b>	7	07	Header	00	00000000
	8	08	ID Manufacture Name LGD	30	00110000
	9	09	ID Manufacture Name	E4	11100100
	10	0A	ID Product Code 0437h	37	00110111
	11	0B	(Hex, LSB first)	04	00000100
	12	0C	ID Serial No. - Optional ("00h" If not used, Number Only and LSB First)	00	00000000
	13	0D	ID Serial No. - Optional ("00h" If not used, Number Only and LSB First)	00	00000000
	14	0E	ID Serial No. - Optional ("00h" If not used, Number Only and LSB First)	00	00000000
	15	0F	ID Serial No. - Optional ("00h" If not used, Number Only and LSB First)	00	00000000
	16	10	Week of Manufacture - Optinal 00 weeks	00	00000000
	17	11	Year of Manufacture 2013 years	17	00010111
18	12	EDID structure version # = 1	01	00000001	
19	13	EDID revision # = 4	04	00000100	
<b>Display Parameters</b>	20	14	Video input Definition = Input is a Digital Video signal Interface , Colo Bit Depth : 6 Bits per Primary Color , Digital Video Interface Standard Supported: DisplayPort is supported	95	10010101
	21	15	Horizontal Screen Size (Rounded cm) = 28 cm	1C	00011100
	22	16	Vertical Screen Size (Rounded cm) = 16 cm	10	00010000
	23	17	Display Transfer Characteristic (Gamma) = (gamma*100)-100 = Example:(2.2*100)-100=120	78	01111000
<b>Panel Color Coordinates</b>	24	18	Feature Support [ Display Power Management(DPM) ; Standby Mode is not supported, Suspend Mode is not supported, Active Off = Very Low Power is not supported ,Supported ColorEncoding Formats : RGB 4:4:4 , Other Feature Support Flags : No_sRGB, Preferred Timing Mode, No_Display is continuous frequency (Multi-mode_Base EDID and Extension Block).]	02	00000010
	25	19	Red/Green Low Bits (RxRy/GxGy)	BF	10111111
	26	1A	Blue/White Low Bits (BxBy/WxWy)	05	00000101
	27	1B	Red X Rx = 0.604	9A	10011010
	28	1C	Red Y Ry = 0.351	59	01011001
	29	1D	Green X Gx = 0.335	55	01010101
	30	1E	Green Y Gy = 0.558	8E	10001110
	31	1F	Blue X Bx = 0.148	26	00100110
<b>Established Timin</b>	32	20	Blue Y By = 0.113	1D	00011101
	33	21	White X Wx = 0.313	50	01010000
	34	22	White Y Wy = 0.329	54	01010100
	35	23	Established timing 1 ( Optional_00h if not used)	00	00000000
	36	24	Established timing 2 ( Optional_00h if not used)	00	00000000
	37	25	Manufacturer's timings ( Optional_00h if not used)	00	00000000
	38	26	Standard timing ID1 ( Optional_01h if not used)	01	00000001
	39	27	Standard timing ID1 ( Optional_01h if not used)	01	00000001
	40	28	Standard timing ID2 ( Optional_01h if not used)	01	00000001
	41	29	Standard timing ID2 ( Optional_01h if not used)	01	00000001
<b>Standard Timing ID</b>	42	2A	Standard timing ID3 ( Optional_01h if not used)	01	00000001
	43	2B	Standard timing ID3 ( Optional_01h if not used)	01	00000001
	44	2C	Standard timing ID4 ( Optional_01h if not used)	01	00000001
	45	2D	Standard timing ID4 ( Optional_01h if not used)	01	00000001
	46	2E	Standard timing ID5 ( Optional_01h if not used)	01	00000001
	47	2F	Standard timing ID5 ( Optional_01h if not used)	01	00000001
	48	30	Standard timing ID6 ( Optional_01h if not used)	01	00000001
	49	31	Standard timing ID6 ( Optional_01h if not used)	01	00000001
	50	32	Standard timing ID7 ( Optional_01h if not used)	01	00000001
	51	33	Standard timing ID7 ( Optional_01h if not used)	01	00000001
	52	34	Standard timing ID8 ( Optional_01h if not used)	01	00000001
	53	35	Standard timing ID8 ( Optional_01h if not used)	01	00000001

## Product Specification

**APPENDIX A. Enhanced Extended Display Identification Data (EEDID™) 2/3**

	Byte (Dec)	Byte (Hex)	Field Name and Comments	Value (Hex)	Value (Bin)	
<b>Timing Descriptor #1</b>	54	36	Pixel Clock/10,000 (LSB) 138.46 MHz @ 60 Hz	16	00010110	
	55	37	Pixel Clock/10,000 (MSB)	36	00110110	
	56	38	Horizontal Active (HA) (lower 8 bits) 1920 pixels	80	10000000	
	57	39	Horizontal Blanking (HB) (lower 8 bits) 186 pixels	BA	10111010	
	58	3A	Horizontal Active (HA) / Horizontal Blanking (HB) (upper 4:4bits)	70	01110000	
	59	3B	Vertical Active (VA) 1080 lines	38	00111000	
	60	3C	Vertical Blanking (VB) (DE Blanking typ. for DE only panels) 15 lines	0F	00001111	
	61	3D	Vertical Active (VA) / Vertical Blanking (VB) (upper 4:4bits)	40	01000000	
	62	3E	Horizontal Front Porch in pixels (HF) (lower 8 bits) 48 pixels	30	00110000	
	63	3F	Horizontal Sync Pulse Width in pixels (HS) (lower 8 bits) 32 pixels	20	00100000	
	64	40	Vertical Front Porch in lines (VF) : Vertical Sync Pulse Width in lines (VS) (lower 4 bits) 3 lines : 5 lines	35	00110101	
	65	41	Horizontal Front Porch/ Sync Pulse Width/ Vertical Front Porch/ Sync Pulse Width (upper 2bits)	00	00000000	
	66	42	Horizontal Video Image Size (mm) (lower 8 bits) 276 mm	14	00010100	
	67	43	Vertical Video Image Size (mm) (lower 8 bits) 156 mm	9C	10011100	
	68	44	Horizontal Image Size / Vertical Image Size (upper 4 bits)	10	00010000	
	69	45	Horizontal Border = 0 (Zero for Notebook LCD)	00	00000000	
	70	46	Vertical Border = 0 (Zero for Notebook LCD)	00	00000000	
	71	47	Non-Interface, Normal display, no stereo, Digital Separate [ Vsync_NEG, Hsync_POS (outside of V-sync) ]	1A	00011010	
	<b>Timing Descriptor #2</b>	72	48	Flag	00	00000000
		73	49	Flag	00	00000000
		74	4A	Flag	00	00000000
75		4B	Data Type Tag (Descriptor Defined by manufacturer)	00	00000000	
76		4C	Flag	00	00000000	
77		4D	Descriptor Defined by manufacturer	00	00000000	
78		4E	Descriptor Defined by manufacturer	00	00000000	
79		4F	Descriptor Defined by manufacturer	00	00000000	
80		50	Descriptor Defined by manufacturer	00	00000000	
81		51	Descriptor Defined by manufacturer	00	00000000	
82		52	Descriptor Defined by manufacturer	00	00000000	
83		53	Descriptor Defined by manufacturer	00	00000000	
84		54	Descriptor Defined by manufacturer	00	00000000	
85		55	Descriptor Defined by manufacturer	00	00000000	
86		56	Descriptor Defined by manufacturer	00	00000000	
87		57	Descriptor Defined by manufacturer	00	00000000	
88		58	Descriptor Defined by manufacturer	00	00000000	
89		59	Descriptor Defined by manufacturer	00	00000000	
<b>Timing Descriptor #3</b>	90	5A	Flag	00	00000000	
	91	5B	Flag	00	00000000	
	92	5C	Flag	00	00000000	
	93	5D	Data Type Tag ( Alphanumeric Data String (ASCII String) )	FE	11111110	
	94	5E	Flag	00	00000000	
	95	5F	Alphanumeric Data String (ASCII String) L	4C	01001100	
	96	60	Alphanumeric Data String (ASCII String) G	47	01000111	
	97	61	Alphanumeric Data String (ASCII String)	20	00100000	
	98	62	Alphanumeric Data String (ASCII String) D	44	01000100	
	99	63	Alphanumeric Data String (ASCII String) i	69	01101001	
	100	64	Alphanumeric Data String (ASCII String) s	73	01110011	
	101	65	Alphanumeric Data String (ASCII String) p	70	01110000	
	102	66	Alphanumeric Data String (ASCII String) l	6C	01101100	
	103	67	Alphanumeric Data String (ASCII String) a	61	01100001	
	104	68	Alphanumeric Data String (ASCII String) y	79	01111001	
	105	69	Manufacturer P/N(If<13 char-> 0Ah, then terminate with ASC II code 0Ah,set remaining char = 20h)	0A	00001010	
	106	6A	Manufacturer P/N(If<13 char-> 0Ah, then terminate with ASC II code 0Ah,set remaining char = 20h)	20	00100000	
	107	6B	Manufacturer P/N(If<13 char-> 0Ah, then terminate with ASC II code 0Ah,set remaining char = 20h)	20	00100000	

## Product Specification

**APPENDIX A. Enhanced Extended Display Identification Data (EEDID™) 3/3**

	Byte (Dec)	Byte (Hex)	Field Name and Comments	Value (Hex)	Value (Bin)
<i>Timing Descriptor #4</i>	108	6C	Flag	00	00000000
	109	6D	Flag	00	00000000
	110	6E	Flag	00	00000000
	111	6F	Data Type Tag ( Alphanumeric Data String (ASCII String) )	FE	11111110
	112	70	Flag	00	00000000
	113	71	Alphanumeric Data String (ASCII String)	4C	01001100
	114	72	Alphanumeric Data String (ASCII String)	50	01010000
	115	73	Alphanumeric Data String (ASCII String)	31	00110001
	116	74	Alphanumeric Data String (ASCII String)	32	00110010
	117	75	Alphanumeric Data String (ASCII String)	35	00110101
	118	76	Alphanumeric Data String (ASCII String)	57	01010111
	119	77	Alphanumeric Data String (ASCII String)	46	01000110
	120	78	Alphanumeric Data String (ASCII String)	32	00110010
	121	79	Alphanumeric Data String (ASCII String)	2D	00101101
	122	7A	Alphanumeric Data String (ASCII String)	53	01010011
123	7B	Alphanumeric Data String (ASCII String)	50	01010000	
124	7C	Alphanumeric Data String (ASCII String)	42	01000010	
125	7D	Alphanumeric Data String (ASCII String)	32	00110010	
<i>Check</i>	126	7E	Extension flag (# of optional 128 panel ID extension block to follow, Typ = 0)	00	00000000
	127	7F	Check Sum (The 1-byte sum of all 128 bytes in this panel ID block shall = 0)	DD	11011101

Our company network supports you worldwide with offices in Germany, Great Britain, Turkey and the USA.  
For more information please contact:



## DATA DISPLAY GROUP

A **FORTEC** GROUP MEMBER

### **Distec GmbH**

Augsburger Str. 2b  
82110 Germering  
Germany

Phone: +49 (0)89 / 89 43 63-0  
Fax: +49 (0)89 / 89 43 63-131  
E-Mail: [info@datadisplay-group.de](mailto:info@datadisplay-group.de)  
Internet: [www.datadisplay-group.de](http://www.datadisplay-group.de)

### **Display Technology Ltd.**

5 The Oaks Business Village  
Revenge Road, Lordswood  
Chatham, Kent, ME5 8LF  
United Kingdom  
Phone: +44 (0)1634 / 67 27 55  
Fax: +44 (0)1634 / 67 27 54  
E-Mail: [info@displaytechnology.co.uk](mailto:info@displaytechnology.co.uk)  
Internet: [www.datadisplay-group.com](http://www.datadisplay-group.com)

### **Sales Partner:**

### **DATA DISPLAY BİLİŞİM TEKNOLOJİLERİ İÇ VE DIŞ TİCARET LİMİTED ŞİRKETİ**

Barbaros Mh. Ak Zambak Sk. A Blok D:143  
34376 Ataşehir / Istanbul  
Turkey  
Phone: +90 (0)216 / 688 04 68  
Fax: +90 (0)216 / 688 04 69  
E-Mail: [info@data-display.com.tr](mailto:info@data-display.com.tr)  
Internet: [www.data-display.com.tr](http://www.data-display.com.tr)

### **FORTEC Elektronik AG**

Lechwiesenstr. 9  
86899 Landsberg am Lech  
Germany

Phone: +49 (0)8191 / 911 72-0  
Fax: +49 (0)8191 / 217 70  
E-Mail: [sales@fortecag.de](mailto:sales@fortecag.de)  
Internet: [www.fortecag.de](http://www.fortecag.de)

### **Apollo Display Technologies, Corp.**

87 Raynor Avenue,  
Unit 1 Ronkonkoma,  
NY 11779  
United States of America  
Phone: +1 631 / 580-43 60  
Fax: +1 631 / 580-43 70  
E-Mail: [info@apolloDisplays.com](mailto:info@apolloDisplays.com)  
Internet: [www.apolloDisplays.com](http://www.apolloDisplays.com)