



OUR GLOBAL
COMPETENCE
CENTRES

 APOLLO DISPLAY
TECHNOLOGIES



 DISTEC



 DISPLAY
TECHNOLOGY



Datasheet

LG Display

LM315WR1-SSB2

HD-10-163

SPECIFICATION FOR APPROVAL

- () Preliminary specification
- (●) Final specification

Title	31.5" UHD TFT LCD
-------	-------------------

BUYER	
MODEL	

SUPPLIER	LG Display Co., Ltd.
*MODEL	LM315WR1
SUFFIX	SSB2

*When you obtain standard approval, please use the above model name without suffix

APPROVED BY	SIGNATURE DATE
/	
/	
/	

Please return 1 copy for your confirmation with your signature and comments.

APPROVED BY	SIGNATURE DATE
K.H. Hwang / G.Manager	
REVIEWED BY	
S.H. Lee / Manager [C]	
Y.H. Hwang / Manager [M]	
S.H. Han / Manager [O]	
J.H. Lee / Manager [P]	
PREPARED BY	
H.C. Jung / Engineer	



**Product engineering dept.
LG Display Co., Ltd**

Product specification
Contents

No	ITEM	Page
	Cover	1
	Contents	2
	Record of revisions	3
1	General description	5
2	Absolute maximum ratings	6
3	Electrical specifications	7
3-1	Electrical characteristics	7
3-2	Interface connections	10
3-3	Signal timing specifications	16
3-4	Signal timing waveforms	17
3-5	Color input data reference	18
3-6	Power sequence	19
3-7	V _{LCD} Power dip condition	20
4	Optical specifications	21
5	Mechanical characteristics	26
6	Reliability	29
7	International standards	30
7-1	Safety	30
7-2	Environment	30
8	Packing	31
8-1	Designation of lot mark	31
8-2	Packing form	32
9	Precautions	33

Product specification

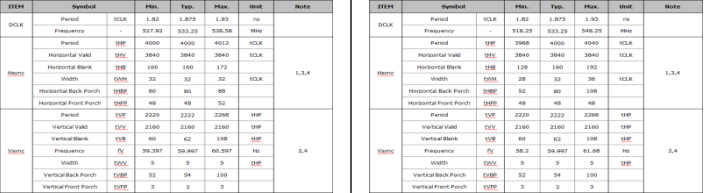
Record of revisions

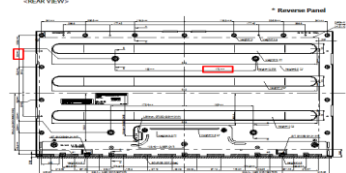
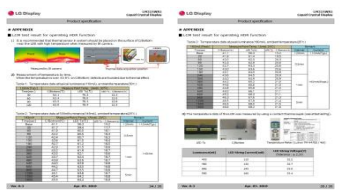
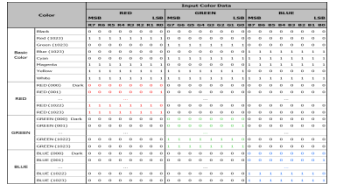
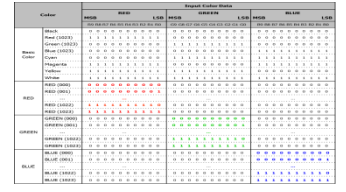
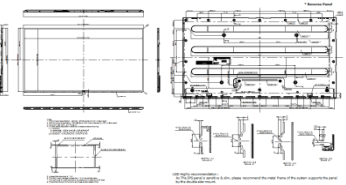
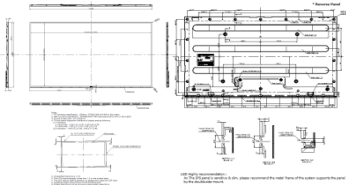
Revision No.	Revision Date	Page	Before	After	Application Date
0.1	Jan. 2. 2018	-	First Draft, Preliminary Specifications	-	-
0.2	Jan. 23. 2018	5, 26	Update the weight spec -. Typ. : TBD g / Max. : TBD g	-. Typ. : (3,250g) / Max. : (3,420g)	Jan. 23. 2018
		16	Update the timing table 		
0.3	Jan. 29. 2018	21	Add the color gamut spec (sRGB Coverage) -	-. Typ. 99% / Min. 95%	Jan. 29. 2018
0.4	Apr. 4. 2018	28	Update the mechanical drawing (UDM Position) 		Apr. 4. 2018
		35, 36	Update LCM test result for operating HDR function (Appendix) -		
0.5	May. 2. 2018	18	Update the spec of color input data reference 		May. 2. 2018
0.6	May. 29. 2018	27, 28	Update the mechanical drawing 		May. 29. 2018

Product specification

1. General description

LM315WR1-SSB2 is a color active matrix liquid crystal display with a light emitting diode (WLED) backlight assembly without LED driver. The matrix employs a-Si thin film transistor as the active element. It is a transmissive type display operating in the normally black mode. It has a 31.5 inch diagonally measured active display area with UHD resolution.(3840 horizontal by 2160 vertical pixels array) Each pixel is divided into red, green and blue sub-pixels or dots which are arranged in vertical stripes. Gray scale or the brightness of the sub-pixel color is determined with a 10-bit gray scale signal for each dot, thus, presenting a palette of more than 1.07Billion colors. It has been designed to apply eDP(HBR2, 5.4Gbps) interface. It is intended to support displays where high brightness, super wide viewing angle, high color saturation, and high color are important.

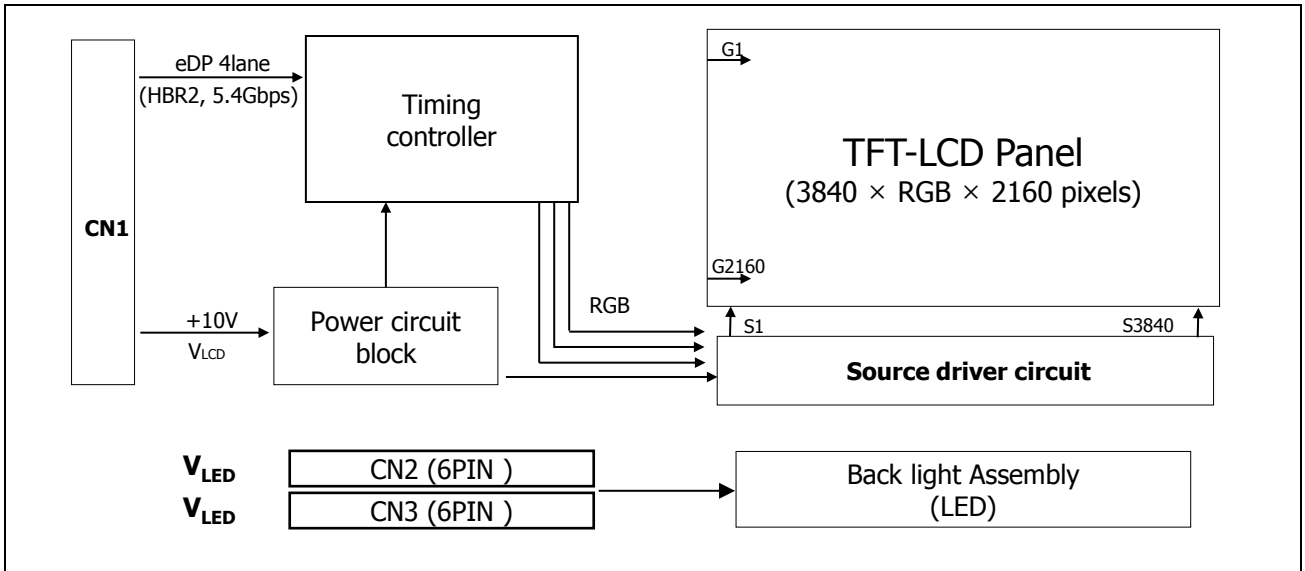

[FIG. 1] Block diagram

General features

Active screen size	31.5 inches(80.0051cm) (Aspect ratio 16:9)
Outline dimension	709.4(H) x 405.85(V) x 14.2 mm (Typ.)
Pixel pitch	0.18159(H)mm x 0.18159(V)mm
Pixel format	3840(H) x 2160(V) Pixels. RGB stripes arrangement
Color depth	1.07Billion colors (8bit + A-FRC)
Luminance (@White)	400 cd/m ² (Center 1 Point, Typ.)
Viewing angle(CR>10)	View angle free (R/L 178(Typ.), U/D 178(Typ.))
Power consumption	Total 36.9 Watt (8.5Watt @V _{LCD} , 28.4 Watt @I _s =110mA)
Weight	3,190g (Typ.)
Display operating mode	Transmissive mode, normally black
Panel type	Reverse type
Surface treatment	Advanced Anti-glare treatment of the front polarizer (3H)

Product specification

2. Absolute maximum ratings

The following are maximum values which, if exceeded, may cause faulty operation or damage to the unit.

Table 1. Absolute maximum ratings

Parameter	Symbol	Values		Units	Notes
		Min.	Max.		
Power supply input voltage	V_{LCD}	-0.3	12.0	V_{DC}	At 25°C
Operating temperature	T_{OP}	0	50	°C	1,2,3
Storage temperature	T_{ST}	-20	60	°C	
Operating ambient humidity	H_{OP}	10	90	%RH	
Storage humidity	H_{ST}	10	90	%RH	
LCM surface temperature (Operation)	$T_{Surface}$	0	65	°C	1, 4

Notes :

- Temperature and relative humidity range are shown in the figure below.
Wet bulb temperature should be 39 °C Max., and no condensation of water.
- Maximum storage humidity is up to 40 °C, 70% RH only for 4 corner light leakage mura.
- Storage condition is guaranteed under packing condition
- LCM surface temperature should be measured under the condition of $V_{LCD}=10.0V$, $f_v=60Hz$, $T_a=25°C$, no humidity and typical LED string current.
※. T_a = Ambient temperature

[FIG. 2] Temperature and relative humidity

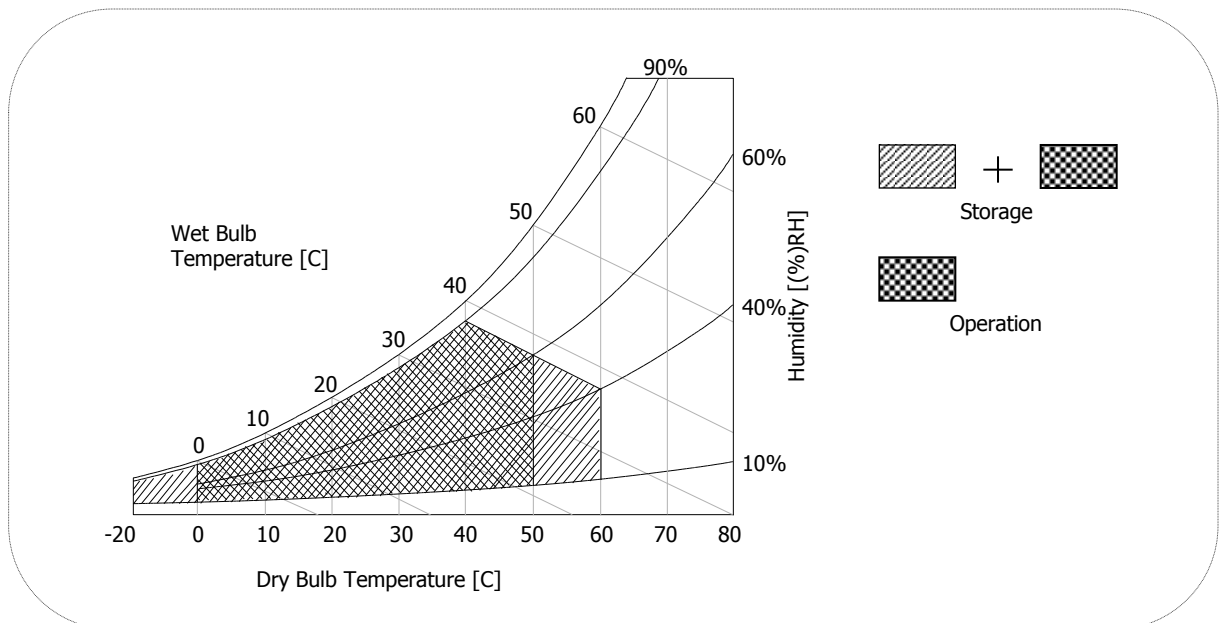

Product specification
3. Electrical specifications
3-1. Electrical characteristics

It requires two power inputs. One is employed to power the LCD electronics and to drive the TFT array and liquid crystal. The other input power for the LED/Backlight, is typically generated by a LED Driver. The LED Driver is an external unit to the LCDs.

Table 2-1. Electrical characteristics

Parameter	Symbol	Values			Units	Notes
		Min	Typ	Max		
MODULE :						
Power supply input voltage	V_{LCD}	9.5	10.0	10.5	V	4
Permissive power input ripple	V_{ripple}			400	mVp-p	1
Power supply input current	I_{LCD} Typ.	-	0.85	1.06	A	2
	I_{LCD} Max.	-	1.12	1.40	A	
Power consumption	P_c Typ.	-	8.5	10.6	Watt	
	P_c Max.	-	11.2	14.0	Watt	
Rush current	I_{RUSH}	-		3	A	3

Notes :

- Permissive power ripple should be measured under the condition of $V_{LCD}=10.0V$, $25^{\circ}C$, $*fv=\max$. Refer to page 7 for the pattern and more information.
- The specified current and power consumption can be measured under the $V_{LCD}=10.0V$, $25^{\circ}C$, $f_v=60Hz$ and the pattern should be changed according to the typical or maximum power condition. The max. current can be measured only with the maximum power pattern. See the page 7 for details.
- Maximum condition of inrush current :
The duration of rush current is about 5ms and rising time of power input is $500\mu s \pm 20\%$. (min.).
- V_{LCD} level must be measured between two points on PCB of LCM [V_{LCD} (test point) ~ LCM Ground] (Test condition : maximum power pattern, $25^{\circ}C$, $f_v=60Hz$)

* f_v =frame frequency

Product specification

- **Permissive power input ripple** ($V_{LCD} = 10.0V$, $25^{\circ}C$, f_v (frame frequency)=Max. condition)

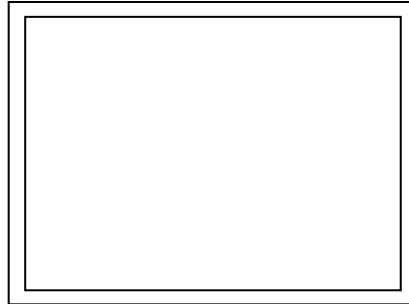

White pattern

For the exact ripple measurement, the condition of max. 20Mhz is recommended in the bandwidth configuration of oscilloscope.

- **Power consumption** ($V_{LCD} = 10V$, $25^{\circ}C$, f_v (frame frequency)=60Hz condition)

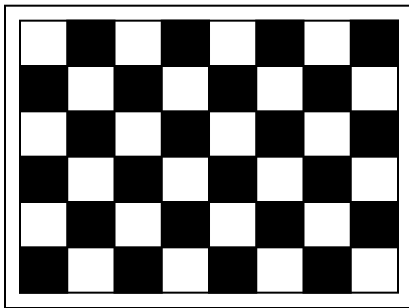

Typical power pattern

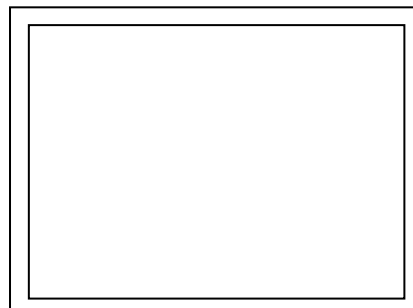

Maximum power pattern

[FIG. 3] Mosaic pattern & White pattern for power consumption measurement

Product specification
Table 2-2. Electrical characteristics of LED bar in normal operating condition

Parameter	Symbol	Values			Units	Notes
		Min.	Typ.	Max.		
LED string current	Is	-	110	115	mA	1, 2
LED string voltage	Vs	30.0	32.2	34.4	V	1, 3
Power consumption	PBar	-	28.4	30.3	Watt	1, 2, 5
LED life time	LED_LT	30,000	-	-	Hour	4

Notes : The LED bar consists of 88 LED packages, 8 strings (parallel) x 11 packages (serial)

1. The specified values are for single LED bar.
2. The specified current is defined as the input current for single LED string with 100% duty cycle.
3. The specified voltage is the input LED string voltage at typical current 100% duty cycle.
4. The LED life time is defined as the time when the brightness of LED itself reach to the 50% of initial value under the conditions at $T_a = 25 \pm 2^\circ\text{C}$ and typical LED string current.
5. The power consumption shown above does not include the loss of external LED driver.
 The typical power consumption is calculated as $P_{\text{Bar}} = V_s(\text{Typ.}) \times I_s(\text{Typ.}) \times \text{No. of strings}$.
 The maximum power consumption is calculated as $P_{\text{Bar}} = V_s(\text{Max.}) \times I_s(\text{Typ.}) \times \text{No. of strings}$.

Product specification

3-2. Interface connections
3-2-1. LCD Module

- LCD Connector(CN1) : GT05Q-30S-H10-MN (LSMtron), HD2S030HA1 (JAE), KN38B-30S-0.5H(HIROSE) or Equivalent
- Mating Connector : 20453-030T-## (Manufactured by I-PEX) or Equivalent

Table 3. Module connector (CN1) pin configuration

No	Symbol	Description	No	Symbol	Description
1	V _{LCD}	Power Supply +10.0V	16	Lane0P	True Signal for Main Link 0
2	V _{LCD}	Power Supply +10.0V	17	Lane0N	Component Signal for Main Link 0
3	V _{LCD}	Power Supply +10.0V	18	GND	Ground
4	V _{LCD}	Power Supply +10.0V	19	Lane1P	True Signal for Main Link 1
5	V _{LCD}	Power Supply +10.0V	20	Lane1N	Component Signal for Main Link 1
6	NC	No connection	21	GND	Ground
7	GND	Ground	22	Lane2P	True Signal for Main Link 2
8	NC	No Connection(I2C serial interface for LCM)	23	Lane2N	Component Signal for Main Link 2
9	NC	No Connection(I2C serial interface for LCM)	24	GND	Ground
10	GND	Ground	25	Lane3P	True Signal for Main Link 3
11	HPD	Hot Plug Detect Signal	26	Lane3N	Component Signal for Main Link 3
12	GND	Ground	27	GND	Ground
13	AUX_CHN	Component Signal for Auxiliary Channel	28	BIST	L(GND): Black, H(3.3V): Rotational Pattern
14	AUX_CHP	True Signal for Auxiliary Channel	29	NC	No Connection
15	GND	Ground	30	GND	Ground

Notes :

1. All GND(ground) pins should be connected together to the LCD module's metal frame.
2. All V_{LCD} (input power) pins should be connected together.
3. BIST (Build In Self Test) : If Pin No.28 is tied to "High(3.3V)", T-con generates Rotational Pattern.
Time to stay at every pattern is about 2sec.

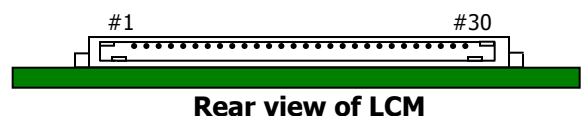
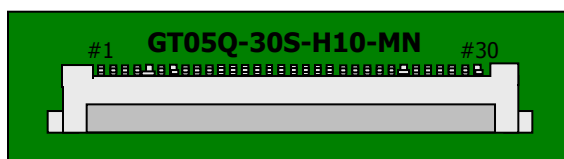
[FIG. 4] Connector diagram

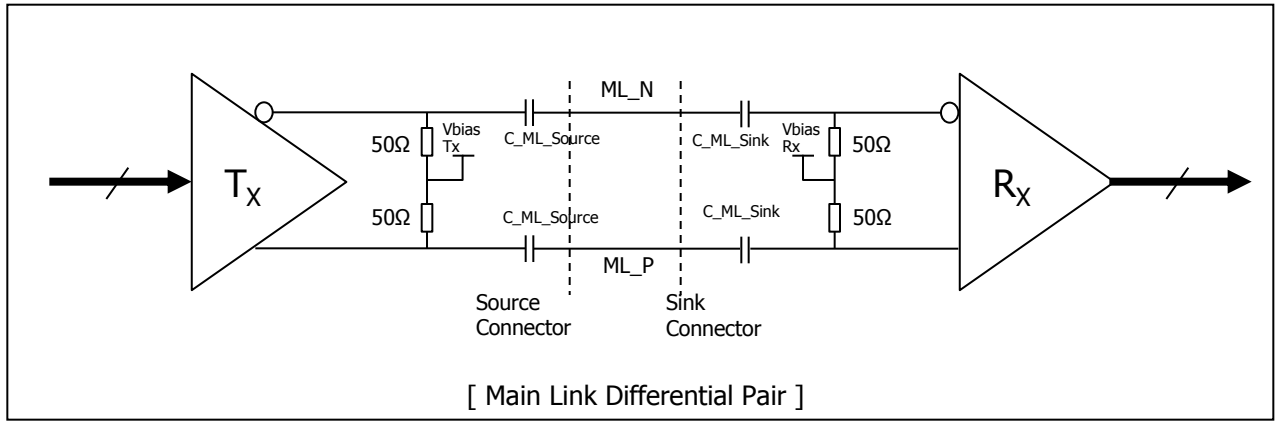
Product specification
3-2-2. eDP Signal specifications
1. eDP Main link signal

Parameter	Symbol	Min	Typ	Max	Unit	Notes
Unit Interval for high bit rate (5.4Gbps / lane)	UI_HBR2	-	185	-	ps	
Link Clock Down Spreading	Amplitude	0	-	0.5	%	
	Frequency	30	-	33	kHz	
Maximum output voltage level at Source side connector	$V_{TX-DIFFp-p-Max}$	-	-	1.38	V	Note 6)
Differential peak-to-peak voltage at Sink side connector	$V_{RX-DIFFp-p}$	0.09	-	-	V	Note 7)
EYE width at Sink side connector	$T_{RX-EYE-CONN}$	0.38	-	-	UI	Note 6,7)
Lane intra-pair skew	$L_{RX-SKEW-INTRA_PAIR}$	-	-	50	ps	
AC Coupling Capacitor	$C_{SOURCE-ML}$	75	-	200	nF	Source side

Note)

1. Termination resistor is typically integrated into the transmitter and receiver implementations.
2. In cabled embedded system, it is recommended the system designer ensure that EYE width and voltage are met at the sink side connector pins.
3. Mismatched common mode voltage will occur abnormal display.
4. All eDP electrical spec is measured at sink connector side.
5. eDP cable Impedance should be 100ohm \pm 5%.

Product specification

Note6) Definition of Differential Voltage

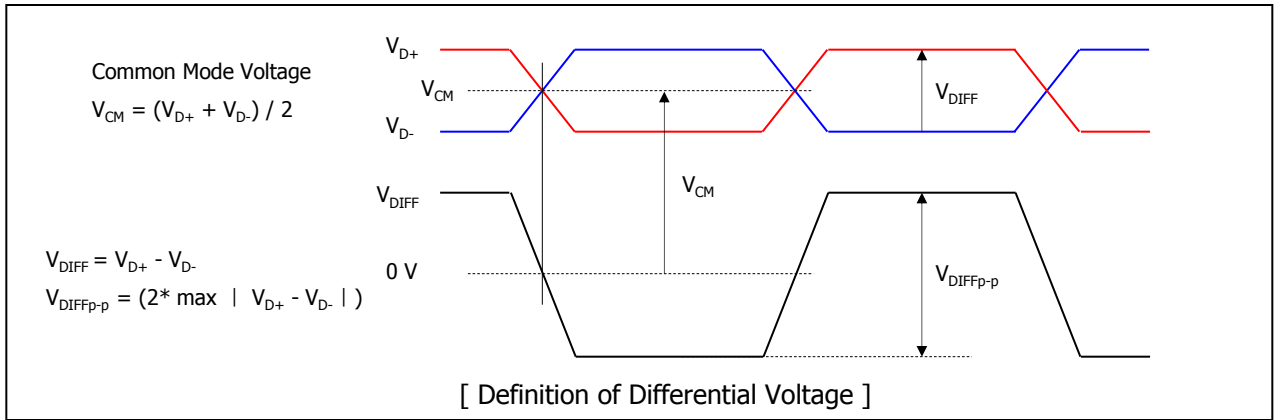

Note7) Main Link EYE Diagram

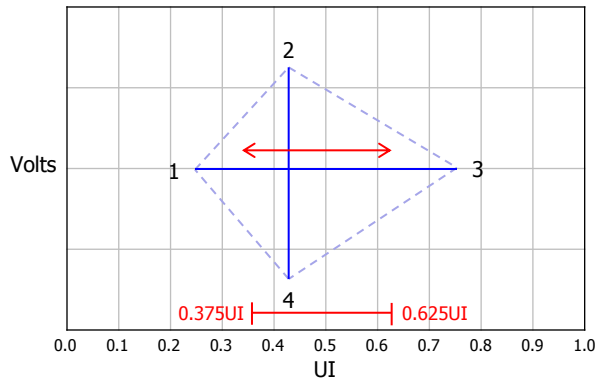

Point	High Bit Rate 2 @ TP3 EQ	
	Time(UI)	Voltage(V)
1	Any UI location (x) where the eye width is open from x to x+0.38UI	0.000
2	Any passing UI location between 0.375UI-0.625UI	0.045
3	Point 1 + 0.38UI	0.000
4	Same as Point 2	-0.045

[EYE Mask Vertices at embedded DP Sink Connector Pins]

Product specification

2. eDP AUX Channel signal

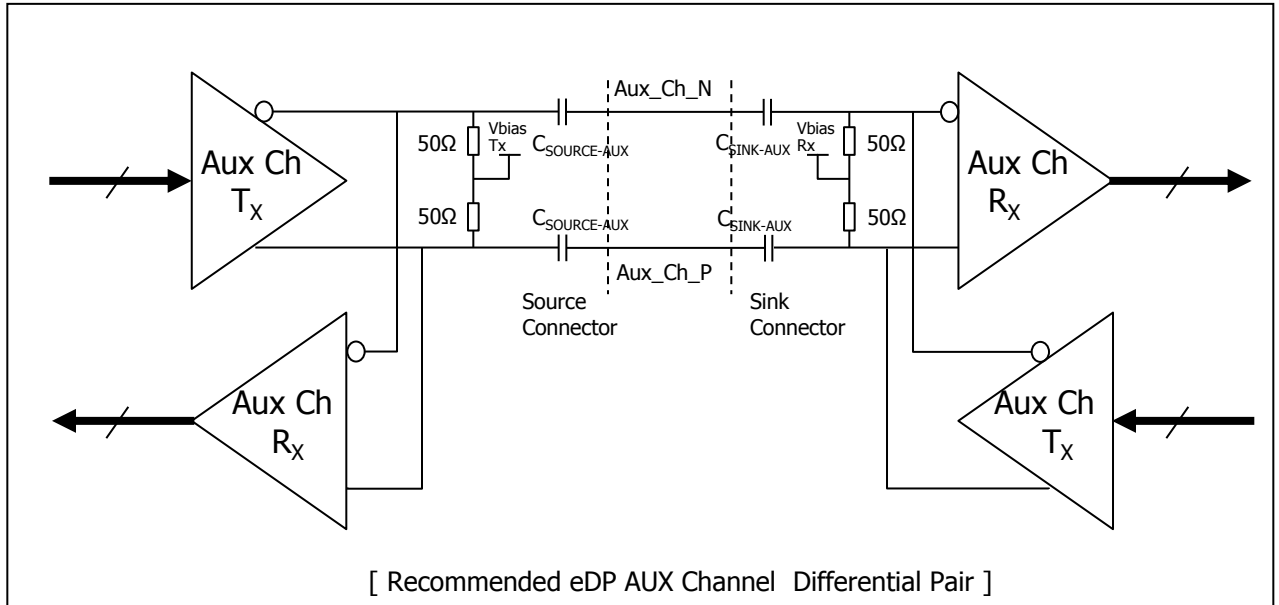

Parameter	Symbol	Min	Typ	Max	Unit	Notes
AUX Unit Interval	UI	0.4	-	0.6	us	
AUX Jitter at Tx IC Package Pins	T_{jitter}	-	-	0.04	UI	Equal to 24ns
AUX Jitter at Rx IC Package Pins		-	-	0.05	UI	Equal to 30ns
AUX Peak-to-peak voltage at Connector Pins of Receiving	$V_{AUX-DIFFP-p}$	0.32	-	1.36	V	
AUX Peak-to-peak voltage at Connector Pins of Transmitting		0.39	-	1.38	V	
AUX EYE width at Connector Pins of Tx and Rx		0.98	-	-	UI	
AUX AC Coupling Capacitor	$C_{SOURCE-AUX}$	75		200	nF	Source side

Note)

1. Termination resistor is typically integrated into the transmitter and receiver implementations.
2. $V_{AUX-DIFFP-p} = 2 * |V_{AUXP} - V_{AUXN}|$
3. Termination resistor should be $\pm 50\Omega$ at source side to AUX level.
4. Mismatched common mode voltage will occur abnormal display.

Product specification

3. eDP HDP Signal

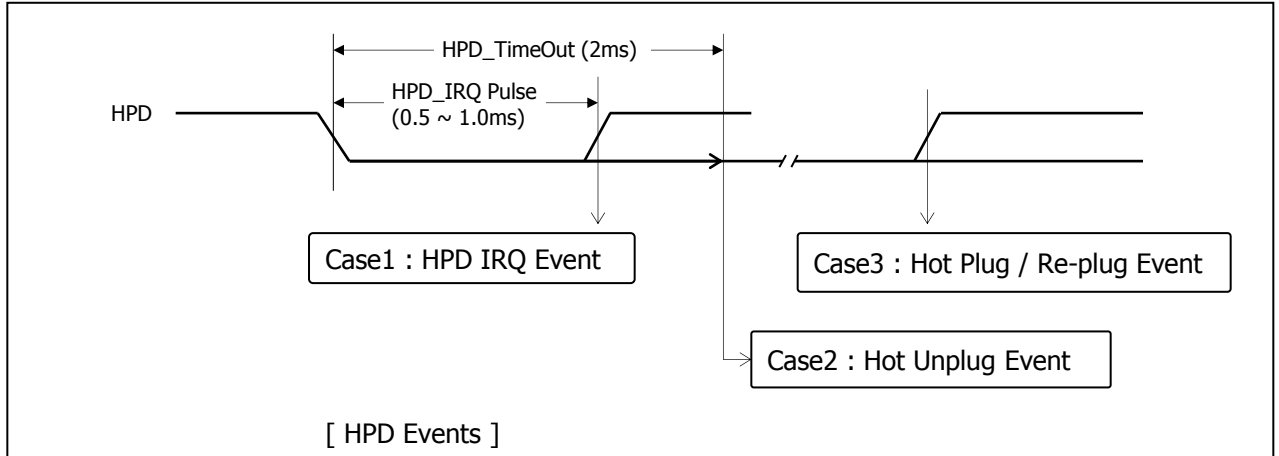

Parameter	Symbol	Min	Typ	Max	Unit	Notes
HPD Voltage	HPD	2.25	-	3.6	V	Sink side Driving
Hot Plug Detection Threshold		2.0	-	-	V	Source side Detecting
Hot Unplug Detection Threshold		-	-	0.8	V	
HPD_IRQ Pulse Width	HPD_IRQ	0.5	-	1.0	ms	
HPD_TimeOut		2.0	-	-	ms	HPD Unplug Event

Note)

1. HPD IRQ : Sink device wants to notify the Source device that Sink's status has changed so it toggles HPD line, forcing the Source device to read its Link / Sink Receiver DPCD field via the AUX-CH
2. HPD Unplug : The Sink device is no longer attached to the Source device and the Source device may then disable its Main Link as a power saving mode
3. Plug / Re-plug : The Sink device is now attached to the Source device, forcing the Source device to read its Receiver capabilities and Link / Sink status Receiver DPCD fields via the AUX-CH

Product specification

3-2-3. Backlight connector pin configuration

Table 4. Backlight connector pin configuration(CN2, CN3)

The LED interface connector is a model BM06B-SHJS(HF)_Manufactured by JST or equivalent.
The mating connector is a SHJP-06V-S(HF), 10035HS-H06C(HF) or equivalent.
The pin configuration for the connector is shown in the table below.

Pin	Symbol	Pin-description (CN2)	Remark	Pin	Symbol	Pin-description (CN3)	Remark
#1	FB1	Channel 1 current feedback	Left side in front view	#1	FB1	Channel 1 current feedback	Right side in front view
#2	FB2	Channel 2 current feedback		#2	FB2	Channel 2 current feedback	
#3	V LED	LED power supply (common anode)		#3	V LED	LED power supply (common anode)	
#4	V LED	LED power supply (common anode)		#4	V LED	LED power supply (common anode)	
#5	FB3	Channel 3 current feedback		#5	FB3	Channel 3 current feedback	
#6	FB4	Channel 4 current feedback		#6	FB4	Channel 4 current feedback	

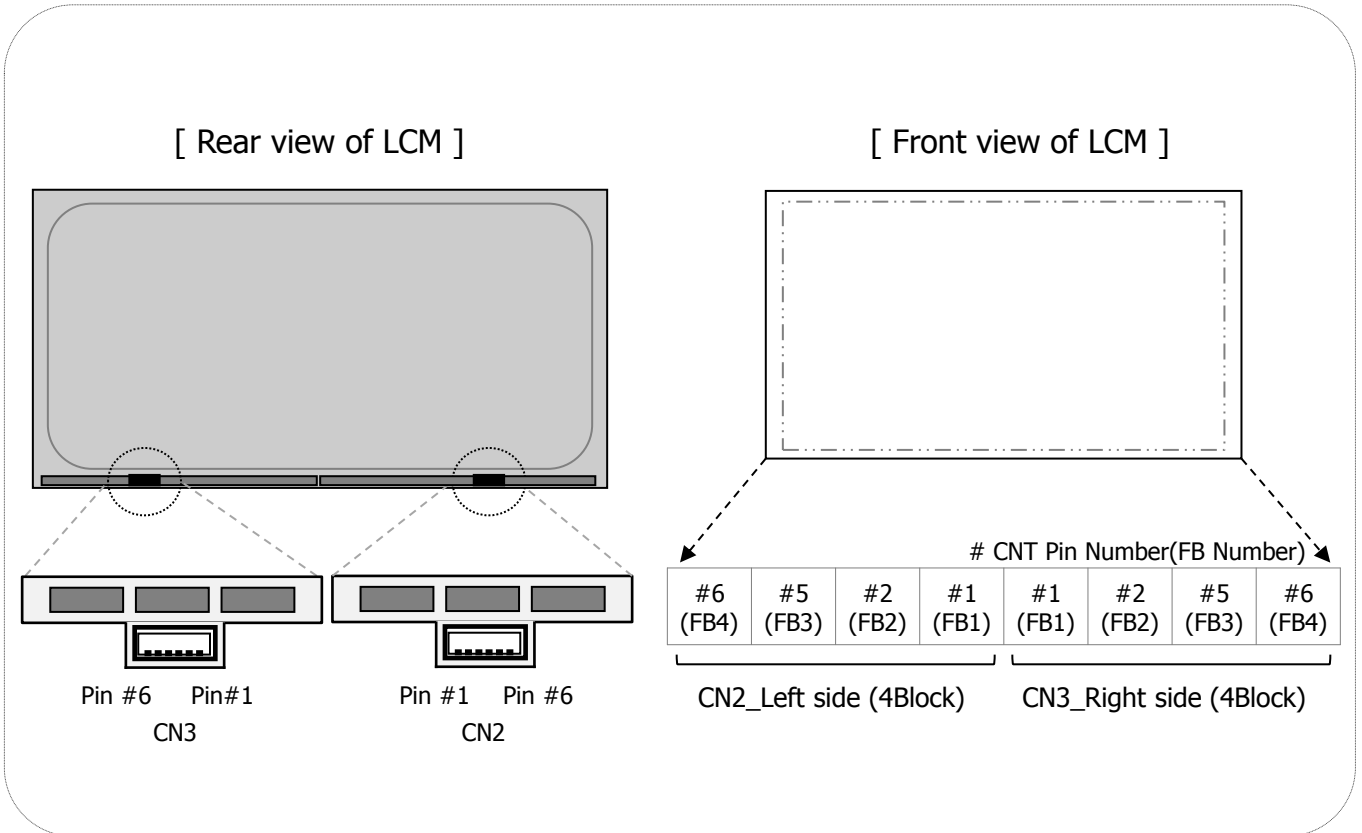

[FIG. 5] Backlight connector view

Product specification
3-3. Signal timing specifications

This is signal timing requirement from the signal transmitter. All of the interface signal timing should satisfy the following specifications for its proper operation.

Table 5. Timing table

ITEM	Symbol		Min.	Typ.	Max.	Unit	Note
DCLK	Period	tCLK	1.82	1.875	1.93	ns	
	Frequency	-	518.25	533.25	548.25	MHz	
Hsync	Period	tHP	3968	4000	4040	tCLK	1,3,4
	Horizontal Valid	tHV	3840	3840	3840	tCLK	
	Horizontal Blank	tHB	128	160	192		
	Width	tWH	28	32	36	tCLK	
	Horizontal Back Porch	tHBP	52	80	108		
	Horizontal Front Porch	tHFP	48	48	48		
Vsync	Period	tVP	2220	2222	2268	tHP	2,4
	Vertical Valid	tVV	2160	2160	2160	tHP	
	Vertical Blank	tVB	60	62	108	tHP	
	Frequency	fV	58.2	59.997	61.68	Hz	
	Width	tWV	5	5	5	tHP	
	Vertical Back Porch	tVBP	52	54	100		
	Vertical Front Porch	tVFP	3	3	3		

Notes :

- 1.The value of Hsync period, Hsync width and Hsync valid should be even number times of tCLK.
If the value is odd number times of tCLK, it can make asynchronous signal timing and cause abnormal display.
- 2.The performance of the electro-optical characteristics may be influenced by variance of the vertical refresh rates.
- 3.The value of Hsync Period, Hsync Width, and Horizontal Back Porch should be divided by 4 without a remainder.
4. The polarity of Hsync, Vsync is not restricted.

Product specification

3-4. Signal timing waveforms

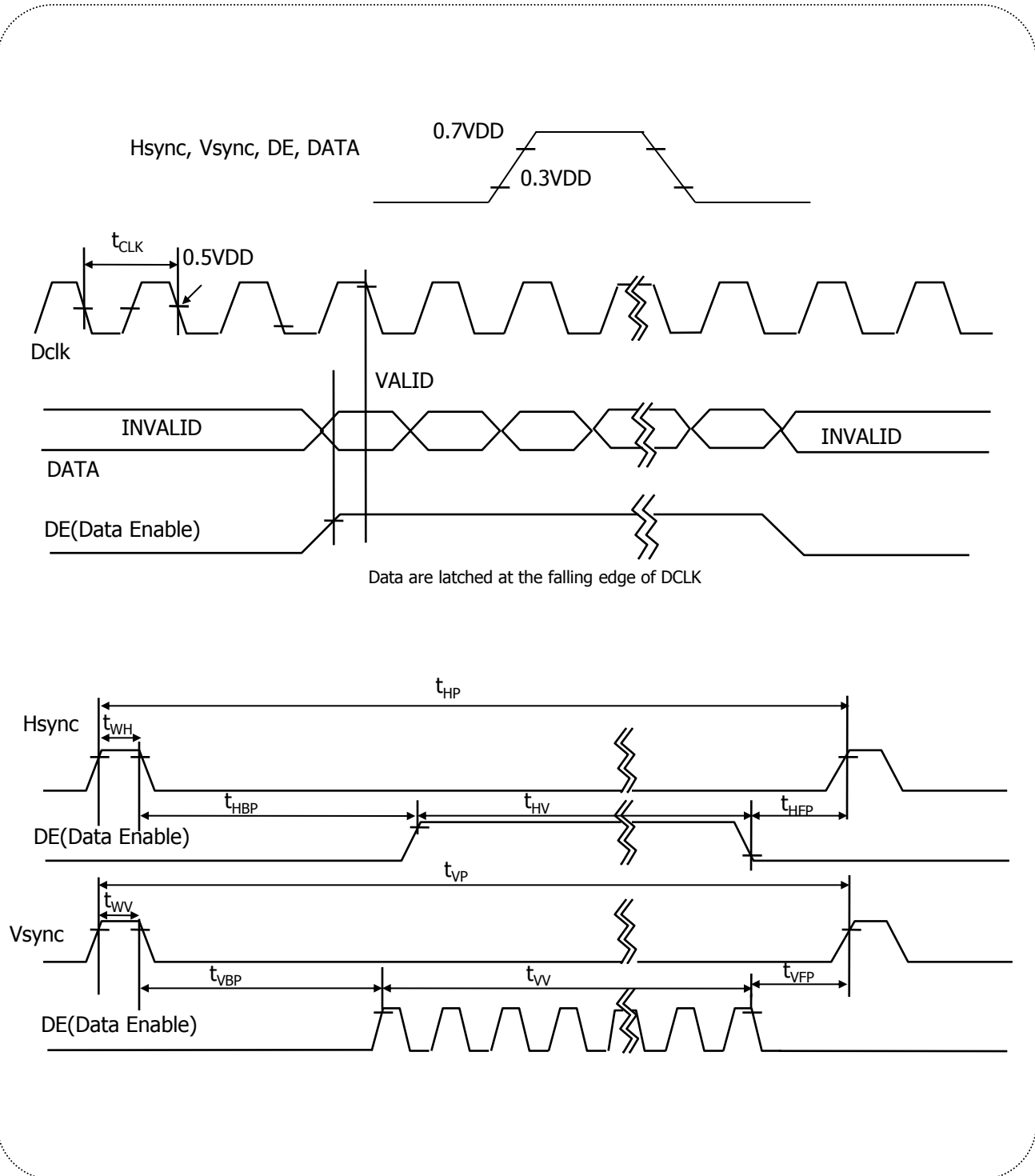

Product specification

3-5. Color input data reference

The brightness of each primary color(red,green,blue) is based on the 10-bit gray scale data input for the color; the higher the binary input, the brighter the color. The table below provides a reference for color versus data input.

Table 6. Color data reference

Color		Input Color Data																													
		RED										GREEN										BLUE									
		MSB					LSB					MSB					LSB					MSB				LSB					
		R9	R8	R7	R6	R5	R4	R3	R2	R1	R0	G9	G8	G7	G6	G5	G4	G3	G2	G1	G0	B9	B8	B7	B6	B5	B4	B3	B2	B1	B0
Basic Color	Black	0	0	0	0	0	0	0	0	0	0	0	0	0	0	0	0	0	0	0	0	0	0	0	0	0	0	0	0	0	0
	Red (1023)	1	1	1	1	1	1	1	1	1	1	0	0	0	0	0	0	0	0	0	0	0	0	0	0	0	0	0	0	0	0
	Green (1023)	0	0	0	0	0	0	0	0	0	0	1	1	1	1	1	1	1	1	1	1	0	0	0	0	0	0	0	0	0	0
	Blue (1023)	0	0	0	0	0	0	0	0	0	0	0	0	0	0	0	0	0	0	0	0	1	1	1	1	1	1	1	1	1	1
	Cyan	0	0	0	0	0	0	0	0	0	0	1	1	1	1	1	1	1	1	1	1	1	1	1	1	1	1	1	1	1	1
	Magenta	1	1	1	1	1	1	1	1	1	1	0	0	0	0	0	0	0	0	0	0	1	1	1	1	1	1	1	1	1	1
	Yellow	1	1	1	1	1	1	1	1	1	1	1	1	1	1	1	1	1	1	1	1	0	0	0	0	0	0	0	0	0	0
	White	1	1	1	1	1	1	1	1	1	1	1	1	1	1	1	1	1	1	1	1	1	1	1	1	1	1	1	1	1	1
RED	RED (000)	0	0	0	0	0	0	0	0	0	0	0	0	0	0	0	0	0	0	0	0	0	0	0	0	0	0	0	0	0	
	RED (001)	0	0	0	0	0	0	0	0	0	0	0	0	0	0	0	0	0	0	0	0	0	0	0	0	0	0	0	0	0	
									
	RED (1022)	1	1	1	1	1	1	1	1	1	0	0	0	0	0	0	0	0	0	0	0	0	0	0	0	0	0	0	0	0	0
	RED (1023)	1	1	1	1	1	1	1	1	1	1	0	0	0	0	0	0	0	0	0	0	0	0	0	0	0	0	0	0	0	0
GREEN	GREEN (000)	0	0	0	0	0	0	0	0	0	0	0	0	0	0	0	0	0	0	0	0	0	0	0	0	0	0	0	0	0	
	GREEN (001)	0	0	0	0	0	0	0	0	0	0	0	0	0	0	0	0	0	0	0	0	0	0	0	0	0	0	0	0	0	
									
	GREEN (1022)	0	0	0	0	0	0	0	0	0	0	1	1	1	1	1	1	1	1	1	0	0	0	0	0	0	0	0	0	0	0
	GREEN (1023)	0	0	0	0	0	0	0	0	0	0	1	1	1	1	1	1	1	1	1	1	0	0	0	0	0	0	0	0	0	0
BLUE	BLUE (000)	0	0	0	0	0	0	0	0	0	0	0	0	0	0	0	0	0	0	0	0	0	0	0	0	0	0	0	0	0	
	BLUE (001)	0	0	0	0	0	0	0	0	0	0	0	0	0	0	0	0	0	0	0	0	0	0	0	0	0	0	0	0	1	
									
	BLUE (1022)	0	0	0	0	0	0	0	0	0	0	0	0	0	0	0	0	0	0	0	0	1	1	1	1	1	1	1	1	1	0
	BLUE (1023)	0	0	0	0	0	0	0	0	0	0	0	0	0	0	0	0	0	0	0	0	1	1	1	1	1	1	1	1	1	1

Product specification

3-6. Power sequence

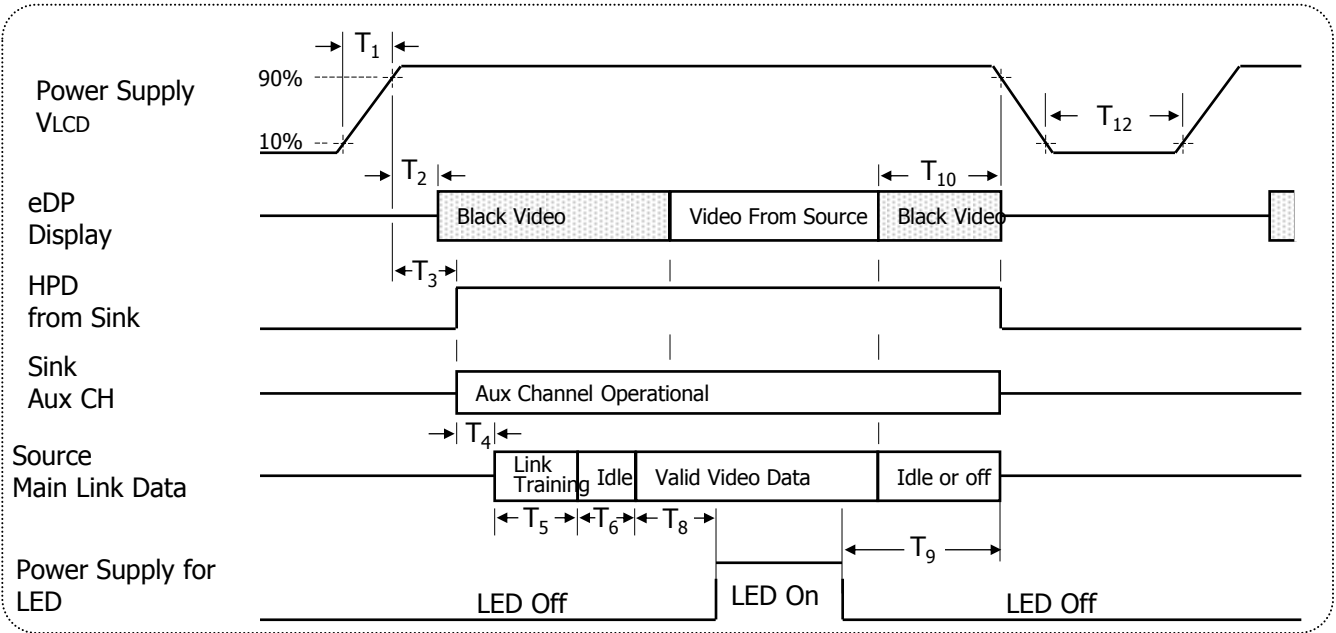

Table 7. Power sequence table

Timing	Required By	Limits		Units	Notes
		Min	Max		
T_1	Source	0.5	10	ms	-
T_2	Sink	10	200	ms	-
T_3	Sink	15	200	ms	-
T_4	Source	-	-	ms	Note 5)
T_5	Source	-	-	ms	Note 5)
T_6	Source	-	100	ms	Note 6)
T_8	Source	200	-	ms	-
T_9	Source	200	-	ms	Note 4)

Timing	Required By	Limits		Units	Notes
		Min	Max		
T_{10}	Source	0	500	ms	-
T_{12}	Source	1000	-	ms	-

Note:

- Power sequence should be kept all the time including below cases for normal operation.
 - AC/DC Power On/Off
 - Mode change (resolution, frequency, timing, sleep mode, color depth change, etc.)
 The violation of power sequence can cause a significant trouble in display and reliability.
- Please avoid floating state of interface signal during signal invalid period.
- When the interface signal is invalid, be sure to pull down the VLCD.(0V)
- Please turn off the power supply for LED when the level of VLCD changes to prevent noise issue.
- Link training duration is dependent on the customer's system.
- It includes Source Frame Synchronization time.

Source Frame Synchronization: Time to prepare before Tx(Source) sends valid data(Invalid period)
- When the LED power and the LCD VLCD are turned off simultaneously, the display may momentarily show abnormal screen

3-7. V_{LCD} Power dip condition

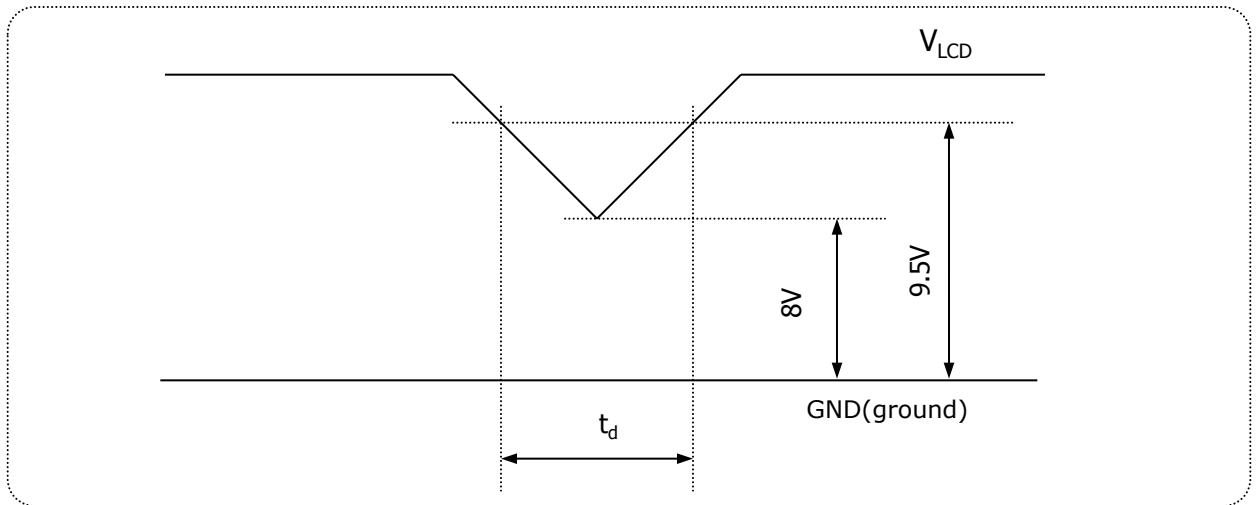

[FIG. 6] Power dip condition

For proper operation, stable power supply of V_{LCD} is necessary and power dip is allowed only in below condition. Except this condition, power on/off should follow power sequence specification in previous page exactly.

1) Dip condition

$$8V \leq V_{LCD} < 9.5V, t_d \leq 20ms$$

Product specification
4. Optical specifications

Optical characteristics are determined after the unit has been 'ON' for approximately 30 minutes in a dark environment at $25 \pm 2^\circ\text{C}$. The values specified are at an approximate distance 50cm from the LCD surface at a viewing angle of Φ and θ equal to 0° and aperture 1 degree.

FIG. 7 presents additional information concerning the measurement equipment and method.

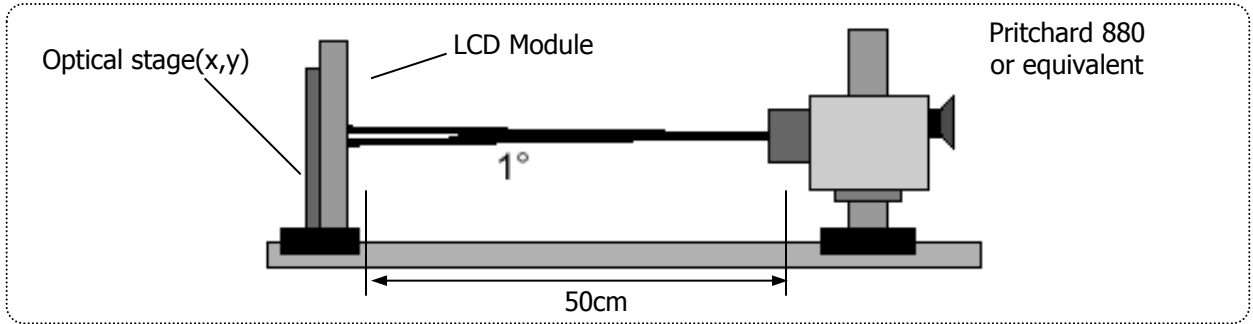

[FIG. 7] Optical characteristic measurement equipment and method

Table 8. Optical characteristics ($T_a=25^\circ\text{C}$, $V_{\text{LCD}}=10.0\text{V}$, $f_v=60\text{Hz}$ Dclk=533.25MHz, $I_s=110\text{mA}$)

Parameter	Symbol	Values			Units	Notes	
		Min.	Typ.	Max.			
Contrast Ratio	CR	910	1300	-		1	
Surface luminance, white	L_{WH}	320	400	-	cd/m ²	2	
Luminance variation	δ_{WHITE}	75	-	-	%	3	
Response time	Gray To Gray	$T_{\text{GTG_AVR}}$	-	14	25	ms	4
Color gamut (CIE1931)	sRGB	95	99	-	%		
Color coordinates [CIE1931] (By PR650)	Red	Rx	Typ. -0.03	0.674	Typ. +0.03		
		Ry		0.314			
	Green	Gx		0.277			
		Gy		0.678			
	Blue	Bx		0.154			
		By		0.053			
	White	Wx		0.313			
		Wy		0.329			
Viewing angle (CR>10, General)	Horizontal	θ_H	170	178	-	Degree	5
	Vertical	θ_V	170	178	-		
Gray Scale	-	-	2.2	-	-	6	

Product specification

4-1. Characteristics of Peak luminance
Table 9-1. Absolute maximum value of LED bar and peak luminance

Parameter	Symbol	Values	Unit	Notes
LED string current	Is	160	mA	a,b,c
Peak luminance	Lp	550	nit	

- Notes) a. LED string voltage at maximum current with 100% duty cycle is 33.4 ± 2.2 V at $T_a = 25 \pm 2^\circ\text{C}$.
- b. Table 9-1 is reference data only for HDR Function usage, refer to the appendix of LCM temperature at peak current.
- c. Peak Luminance 550nit is achieved at 160mA, while the specifications for guarantee remains under the normal operating condition specified in Table 2-2. Specifications and condition for evaluation test and mass production shall be applied with conditions specified in Table 2-2.

Product specification

Notes :

1. Contrast Ratio(CR) is defined mathematically as : **(By PR880)**

$$\text{Contrast Ratio} = \frac{\text{Surface luminance with all white pixels}}{\text{Surface luminance with all black pixels}}$$

It is measured at center point(Location P1)

2. Surface luminance(L_{WH}) is luminance value at Center 1 point(P1) across the LCD surface 50cm from the surface with all pixels displaying white. For more information see FIG.7 **(By PR880)**

3. The variation in surface luminance , δ WHITE is defined as : **(By PR880)**

$$\delta_{WHITE} = \frac{\text{Minimum}(L_{P1}, L_{P2}, \dots, L_{P9})}{\text{Maximum}(L_{P1}, L_{P2}, \dots, L_{P9})} \times 100$$

Where L1 to L9 are the luminance with all pixels displaying white at 9 locations.
For more information see FIG.8

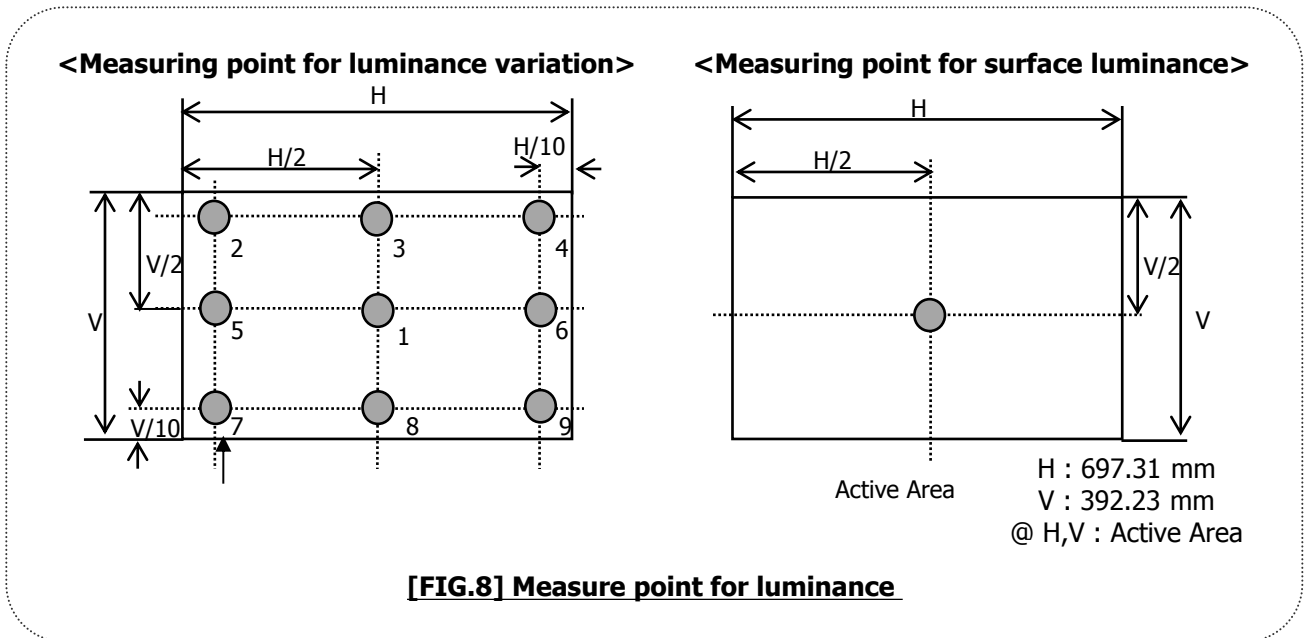

Product specification

4. The Gray To Gray response time is defined as the following figure and shall be measured by switching the input signal for "Gray To Gray".

- Gray step : 5 Step
- TGTG_AVR is the total average time at rising time and falling time for "Gray To Gray".
- By RD80S

Table 9. GTG Gray table

Gray To Gray		Rising time				
		G1023	G767	G511	G255	G0
Falling time	G1023					
	G767					
	G511					
	G255					
	G0					

Response time is defined as the following figure and shall be measured by switching the input signal for "Gray(N)" and "Gray(M)".

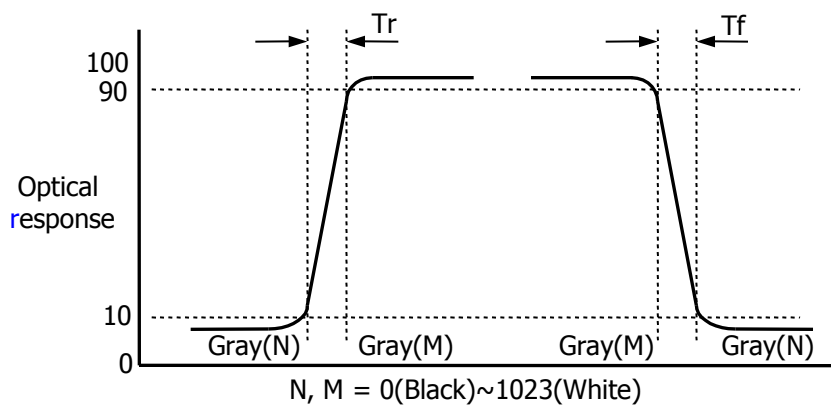

[FIG. 9] Response Time

Product specification

5. Viewing angle is the angle at which the contrast ratio is greater than 10. The angles are determined for the horizontal or x axis and the vertical or y axis with respect to the z axis which is normal to the LCD surface. For more information see FIG.10 (**By PR880**)

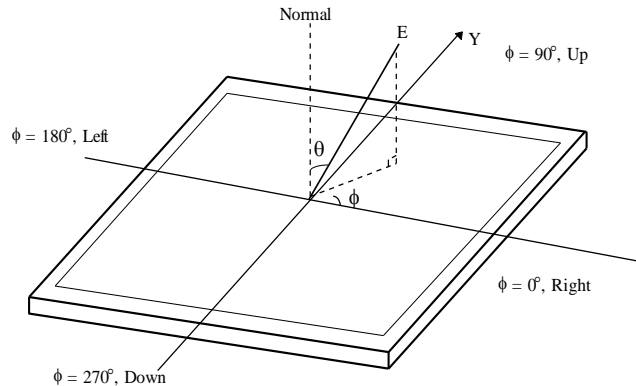

[FIG. 10] Viewing angle

6. Gamma Value is approximately 2.2. For more information see Table 11.

Table 10. Gray Scale Specification

Gray Level	Relative Luminance [%] (Typ.)
0	0.11
127	1.08
255	4.72
383	11.49
511	21.66
639	35.45
767	53.00
895	74.48
1023	100

Product specification
5. Mechanical characteristics

The contents provide general mechanical characteristics. In addition the figures in the next page are detailed mechanical drawing of the LCD.

Outline dimension	Horizontal	709.40 mm
	Vertical	405.85 mm
	Depth	14.20 mm
Bezel area	Horizontal	-
	Vertical	-
Active display area	Horizontal	697.31 mm
	Vertical	392.23 mm
Weight	Typ. : 3,190g, Max. : 3,350g	
Surface Treatment	Advanced Anti-glare treatment of the front polarizer (3H)	

Notes : Please refer to a mechanic drawing in terms of tolerance at the next page.

Outline dimensions (horizontal, vertical and outside depth) are measured by using vernier calipers.
 The inside depth dimensions are measured by using height gauge, when LCM is put face down onto a flat surface.

Product specification

<FRONT VIEW>

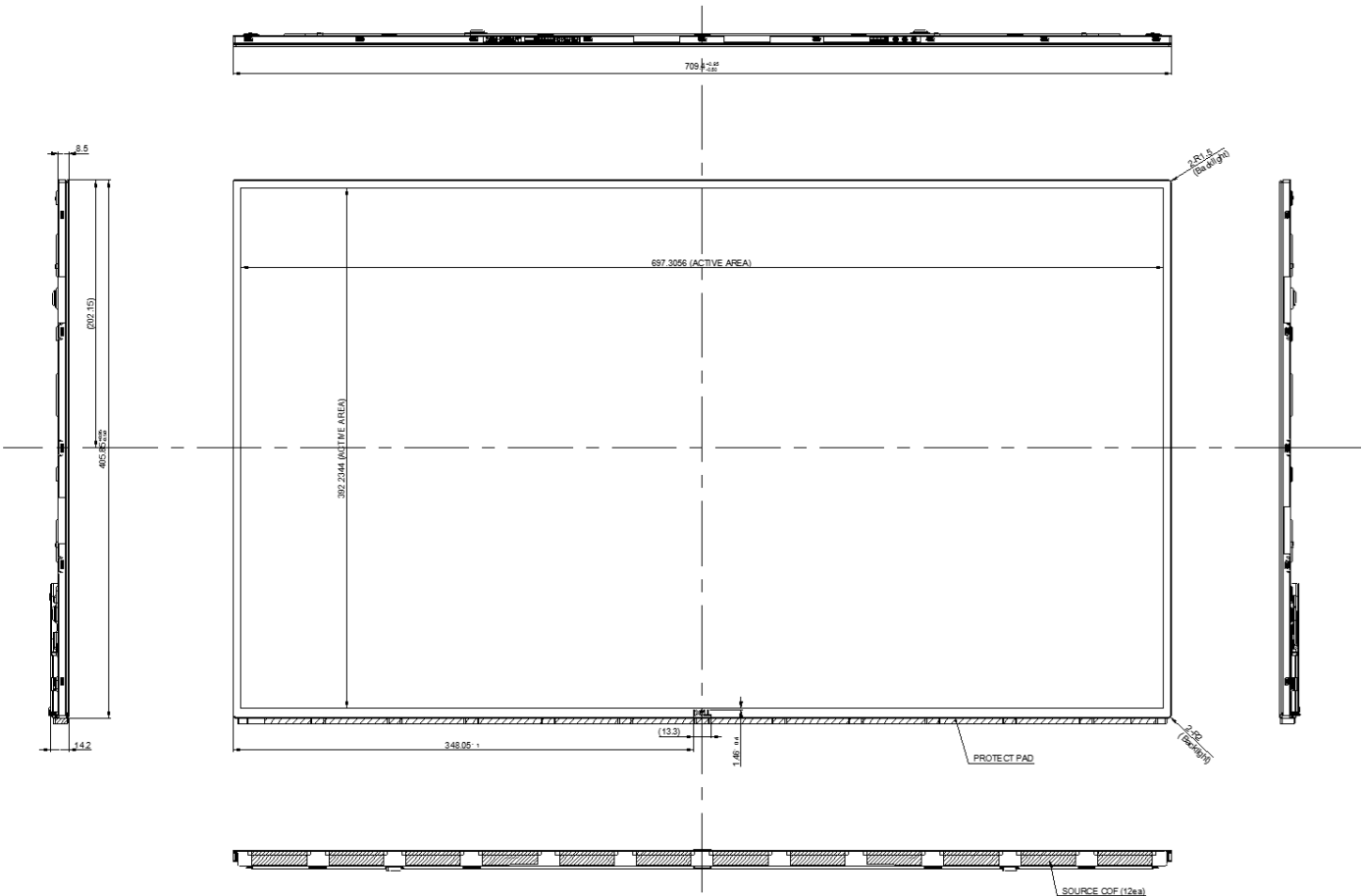

Notes

1. I/F Connector specification : LSMtron, GT05Q-30S-H10-MN or Equivalent
2. LED connector specification : SM06B-SHJH (HF) (Manufactured by JST) or Equivalent
3. Torque of user hole : 3.0~4.0kgf.cm
4. Tilt and partial disposition tolerance of display area as following
 - (1) Y-direction
 - a. Upper side : $-0.45 \leq A \leq 0.45$, $-0.45 \leq B \leq 0.45$
 - b. Lower side : $-0.45 \leq C \leq 0.6$, $-0.45 \leq D \leq 0.6$
 - (2) X-direction : $-0.45 \leq E \leq 0.45$, $-0.45 \leq F \leq 0.45$

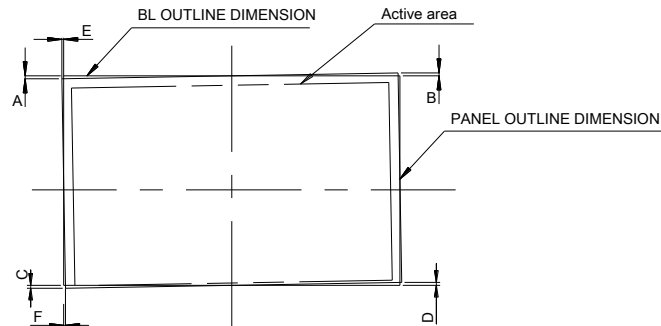

5. Unspecified tolerance is ± 0.5
6. The LCM warp(warpage) is less than 1.0 on the surface plate
7. The COF area is weak & sensitive, so please don't press the COF area
8. Undefined height should follow the 3D Modeling data
9. Protect Pad should not be removed unless system assembling

Product specification

<REAR VIEW>

*** Reverse Panel**

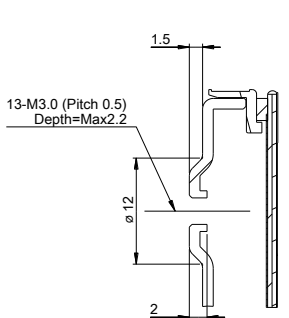
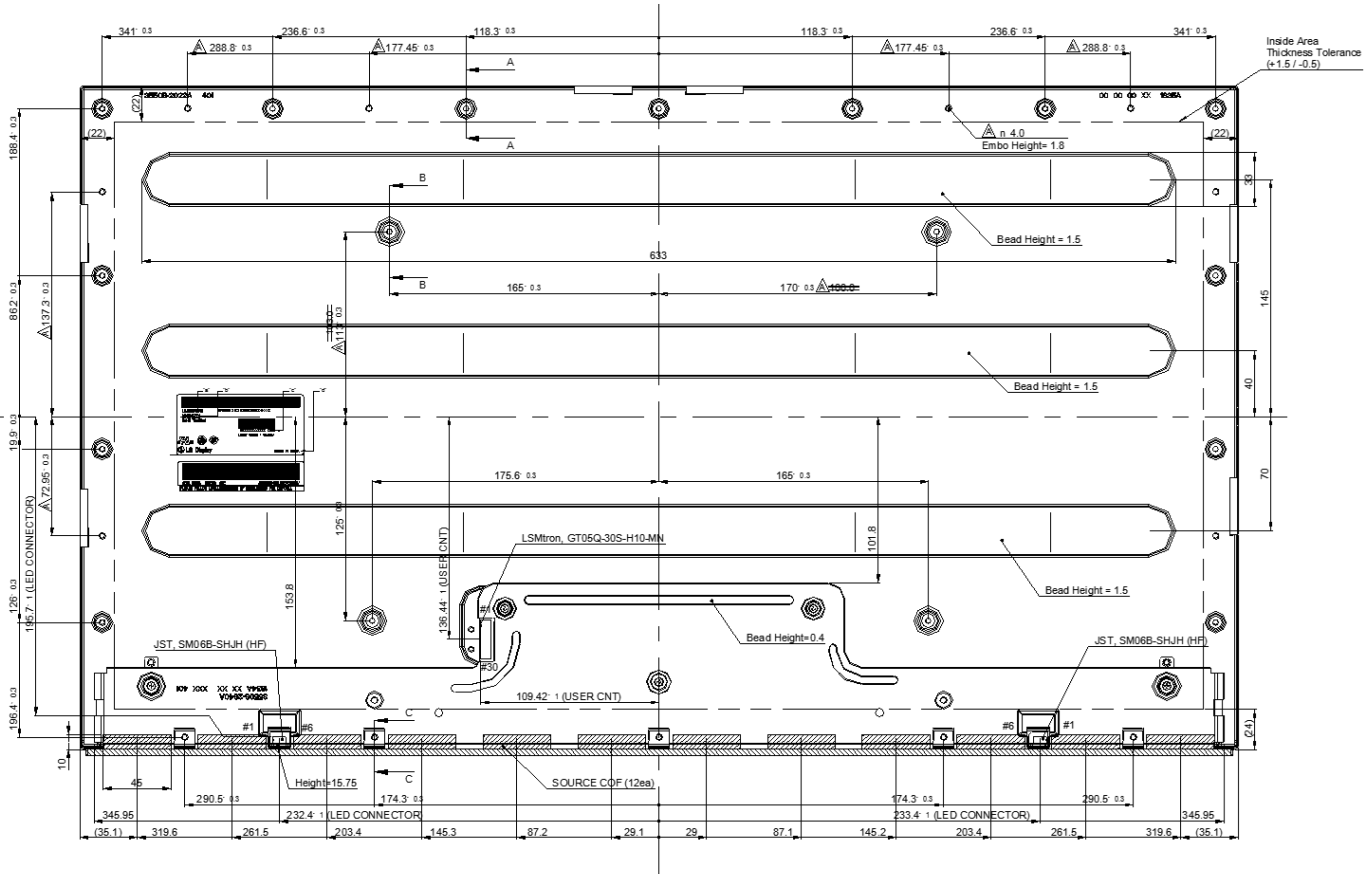

SECTION A-A
SCALE 2/1

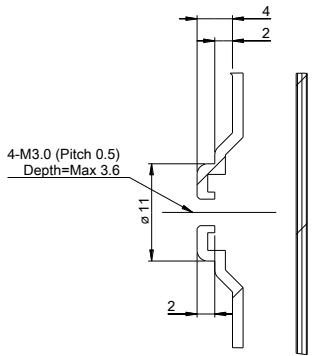

SECTION B-B
SCALE 2/1

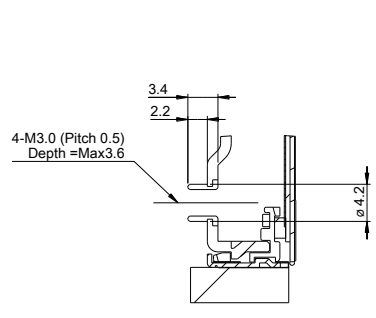

SECTION C-C
SCALE 2/1

LGD Highly recommendation :

As The IPS panel is sensitive & slim, please recommend the metal frame of the system supports the panel by the double side-mount.

Product specification
6. Reliability

Environment test condition

No	Test Item	Condition
1	High temperature storage test	Ta= 60°C 240h
2	Low temperature storage test	Ta= -20°C 240h
3	High temperature operation test	Ta= 50°C 50%RH 240h
4	Low temperature operation test	Ta= 0°C 240h
5	Humidity condition Operation	Ta= 40 °C ,90%RH
6	Altitude operating storage / shipment	0 – 16,400 feet (5,000m) 0 - 40,000 feet (12,192m)
7	Maximum Storage Humidity for 4 corner light leakage Mura.	Max 70%RH , Ta=40°C

Note 1. Result Evaluation Criteria:

TFT-LCD panels test should take place after cooling enough at room temperature.

In the standard condition, there should be no particular problems that may affect the display function.

 ※. T_a= Ambient Temperature

7. International standards

7-1. Safety

- a) UL 60950-1, Underwriters Laboratories Inc.
Information Technology Equipment - Safety - Part 1 : General Requirements.
- b) CAN/CSA-C22.2 No. 60950-1-07, Canadian Standards Association.
Information Technology Equipment - Safety - Part 1 : General Requirements.
- c) EN 60950-1, European Committee for Electrotechnical Standardization (CENELEC).
Information Technology Equipment - Safety - Part 1 : General Requirements.
- d) IEC 60950-1, The International Electrotechnical Commission (IEC).
Information Technology Equipment - Safety - Part 1 : General Requirements

7-2. Environment

- a) RoHS, Directive 2011/65/EU of the European Parliament and of the council of 8 June 2011

Product specification

8. Packing

8-1. Designation of lot mark

a) Lot mark

A	B	C	D	E	F	G	H	I	J	K	L	M
---	---	---	---	---	---	---	---	---	---	---	---	---

A,B,C : SIZE(INCH)
E : MONTH

D : YEAR
F ~ M : SERIAL NO.

Note

1. YEAR

Year	2011	2012	2013	2014	2015	2016	2017	2018	2019	2020
Mark	A	B	C	D	E	F	G	H	J	K

2. MONTH

Month	Jan	Feb	Mar	Apr	May	Jun	Jul	Aug	Sep	Oct	Nov	Dec
Mark	1	2	3	4	5	6	7	8	9	A	B	C

b) Location of lot mark

Serial No. is printed on the label. The label is attached to the backside of the LCD module.
This is subject to change without prior notice.

Product specification

8-2. Packing form

- a) Package quantity in one packing : 8 ea
Package quantity in one Pallet : 24 ea
- b) Packing Size : 814mm X 358 mm X 509 mm
- c) Pallet Ass'y Size: 1140 mm X 870 mm X 652 mm

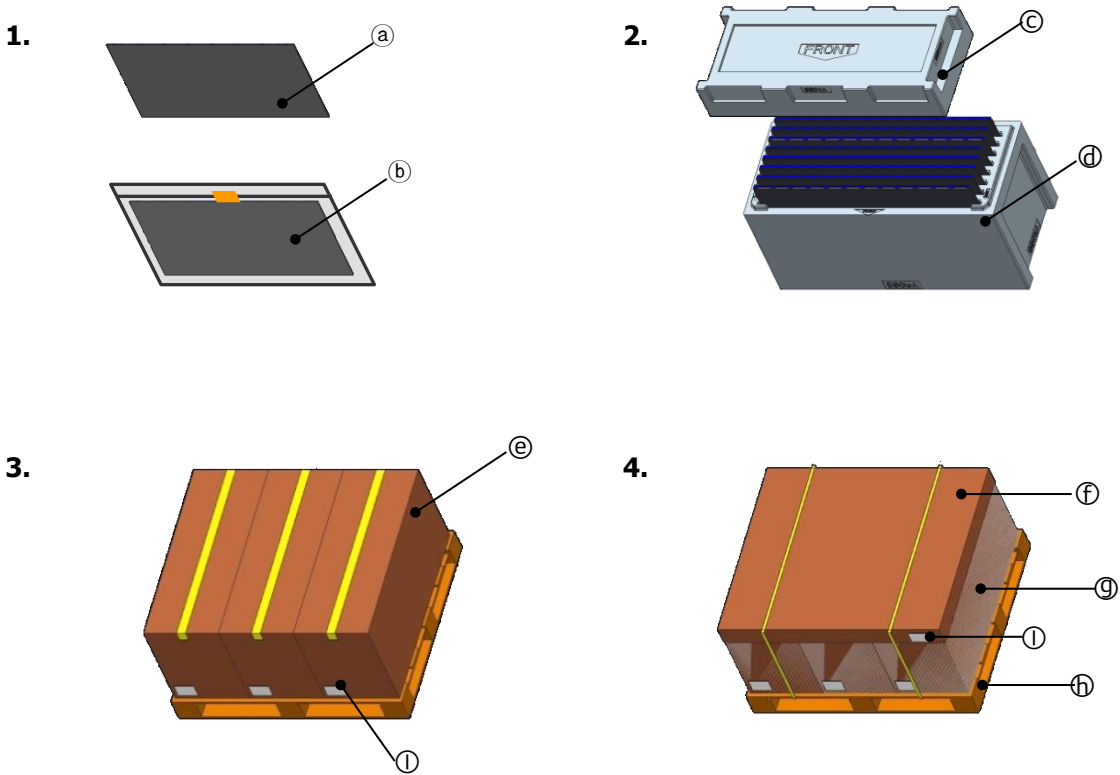

No.	Description	Material
(a)	LCM	-
(b)	AL-Bag	AL
(c)	Packing, Top	EPS
(d)	Packing, Bottom	EPS
(e)	Box	Paper(SW)
(f)	Angle Cover	Paper(SW)
(g)	Wrap	LDPE
(h)	Pallet	Plywood
(l)	Label	YUPO

Product specification

9. Precautions

Please pay attention to the followings when you use this TFT LCD module.

9-1. Mounting precautions

- (1) You must mount a module using holes arranged in rear side.
- (2) You should consider the mounting structure so that uneven force (ex. Twisted stress) is not applied to the module. And the case on which a module is mounted should have sufficient strength so that external force is not transmitted directly to the module.
- (3) Please attach the surface transparent protective plate to the surface in order to protect the polarizer. Transparent protective plate should have sufficient strength in order to resist external force.
- (4) You should adopt radiation structure to satisfy the temperature specification.
- (5) Acetic acid type and chlorine type materials for the cover case are not desirable because the former generates corrosive gas of attacking the polarizer at high temperature and the latter causes circuit break by electro-chemical reaction.
- (6) Do not touch, push or rub the exposed polarizers with glass, tweezers or anything harder than HB pencil lead. And please do not rub with dust clothes with chemical treatment. Do not touch the surface of polarizer for bare hand or greasy cloth. (Some cosmetics are detrimental to the polarizer.)
- (7) When the surface becomes dusty, please wipe gently with absorbent cotton or other soft materials like chamois soaks with petroleum benzene. Normal-hexane is recommended for cleaning the adhesives used to attach front / rear polarizers. Do not use acetone, toluene and alcohol because they cause chemical damage to the polarizer.
- (8) Wipe off saliva or water drops as soon as possible. Their long time contact with polarizer causes deformations and color fading.
- (9) Do not open the case because inside circuits do not have sufficient strength.

9-2. Operating precautions

- (1) Response time depends on the temperature. (In lower temperature, it becomes longer.)
- (2) Brightness depends on the temperature. (In higher temperature, it becomes lower.)
And in lower temperature, response time (required time that brightness is stable after turned on) becomes longer.
- (3) Be careful for condensation at sudden temperature change. Condensation makes damage to polarizer or electrical contacted parts. And after fading condensation, smear or spot will occur.
- (4) When fixed patterns are displayed for a long time, remnant image is likely to occur.
- (5) Module has high frequency circuits. Sufficient suppression to the electromagnetic interference shall be done by system manufacturers. Grounding and shielding methods may be important to minimize the interference.
- (6) Please do not give any mechanical and/or acoustical impact to LCM. Otherwise, LCM can't be operated its full characteristics perfectly.
- (7) A screw which is fastened up the steels should be a machine screw.
(If not, it causes metallic foreign material and deal LCM a fatal blow)
- (8) Please do not set LCD on its edge.
- (9) When LCMs are used for public display, defects such as Yogore & image sticking can not be guaranteed.
- (10) LCM cannot support "Interlaced scan method"
- (11) When this reverse model is used as a forward-type model (PCB on top side), LGD can not guarantee any defects of LCM.
- (12) Please conduct image sticking test after 2-hour aging with Rolling pattern and normal temperature. (25~40°C)

Product specification

9-3. Electrostatic discharge control

Since a module is composed of electronic circuits, it is not strong to electrostatic discharge. Make certain that treatment persons are connected to ground through wrist band etc. And don't touch interface pin directly.

9-4. Precautions for strong light and hazardous materials exposure

Strong light exposure causes degradation of polarizer and color filter.

The LCM should be avoided direct contact with Hazardous materials such as sulfur, acetic acid, chlorine, etc. These materials may cause chemical reaction such as sulfurization, corrosion, discoloration, etc.

9-5. Storage

When storing modules as spares for a long time, the following precautions are necessary.

- (1) Store them in a dark place. Do not expose the module to sunlight or fluorescent light. Keep the temperature between 5°C and 35°C at normal humidity.
- (2) The polarizer surface should not come in contact with any other object.
It is recommended that they be stored in the container in which they were shipped.

9-6. Handling precautions for protection film

- (1) The protection film is attached to the bezel with a small masking tape.
When the protection film is peeled off, static electricity is generated between the film and polarizer. This should be peeled off slowly and carefully by people who are electrically grounded and with well ion-blown equipment or in such a condition, etc.
- (2) When the module with protection film attached is stored for a long time, sometimes there remains a very small amount of glue still on the bezel after the protection film is peeled off.
- (3) You can remove the glue easily. When the glue remains on the bezel surface or its vestige is recognized, please wipe them off with absorbent cotton waste or other soft material like chamois soaked with normal-hexane.

Product specification

APPENDIX

■ LCM test result for operating HDR function

- 1) It is recommended that thermal sensor in system should be placed on the surface of C/Bottom near the LED with high temperature when measured by IR camera.

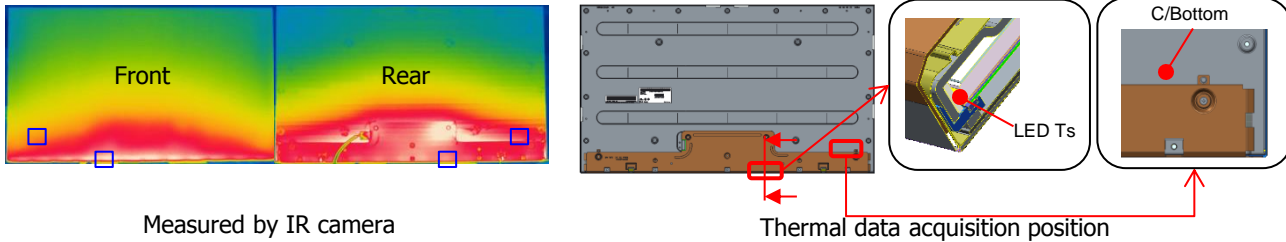

- 2) Measurement of temperature by time.
When the temperature is over 63.9°C on C/Bottom, defects are founded due to thermal effect.

Table 1 : Temperature data at typical luminance(110mA), ambient temperature(50°C)

110mA (Typ.)	Measure Point Temp. (Ambi. 50°C)		
Time(min.)	C/Bottom(°C)	LED Ts(°C)	LED Ts - C/Bottom(°C)
30	62.1	76.3	12.2
60	63.4	78.0	12.6
90	63.5	78.3	12.8
120	63.9	78.4	12.5

Table 2 : Temperature data at 500nit luminance(145mA), ambient temperature(25°C)

145mA	Measure Point Temp. (Ambi. 25°C)			Remark	
Time(sec)	C/Bottom(°C)	LED Ts(°C)	LED Ts - C/Bottom(°C)	Interval	Current
Base	41.1	56.3	15.2	120min	110mA(Typ.)
30	41.7	59.4	17.7	0.5min	145mA
60	41.9	60.0	18.1		
90	42.2	60.5	18.3		
120	42.4	60.7	18.3		
150	42.6	61.0	18.4		
180	42.7	61.2	18.5		
240	42.9	61.5	18.6		
300	43.2	61.9	18.7	1min	
360	43.5	62.1	18.6		
420	43.7	62.4	18.7		
480	43.9	62.6	18.7		
540	44.0	62.8	18.8		
600	44.2	63.0	18.8	5min	
900	44.7	63.5	18.8		
1200	45.1	63.8	18.7		
1500	45.4	64.2	18.8		
1800	45.5	64.4	18.9		

Product specification

APPENDIX

■ LCM test result for operating HDR function

Table 3 : Temperature data at peak luminance(160mA), ambient temperature(25 °C)

160mA (Peak) Time(sec)	Measure Point Temp. (Ambi. 25°C)			Remark	
	C/Bottom(°C)	LED Ts(°C)	LED Ts - C/Bottom(°C)	Interval	Current
Base	41.1	56.3	15.2	120min	110mA(Typ.)
30	41.9	61.4	19.5	0.5min	160mA(Peak.)
60	42.0	62.3	20.3		
90	42.3	62.9	20.6		
120	42.7	63.3	20.6		
150	43.0	63.6	20.6		
180	43.1	64.0	20.9		
240	43.6	64.5	20.9		
300	44.0	64.9	20.9	1min	
360	44.2	65.2	21.0		
420	44.6	65.6	21.0		
480	44.8	65.8	21.0		
540	45.0	66.1	21.1		
600	45.2	66.3	21.1	5min	
900	46.3	67.6	21.3		
1200	46.5	67.9	21.4		
1500	46.5	68.0	21.5		
1800	46.6	68.2	21.6		

3) The temperature data of the LCM was measured by using a contact thermocouple (see attached Fig).

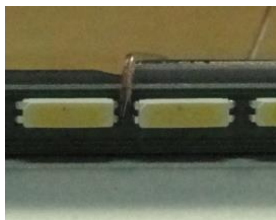

LED Ts



C/Bottom



Temperature Meter (Lutron TM-947SD / 4ch)

GENERAL SPECIFICATIONS			
Circuit	Custom one-chip of microprocessor LSI circuit.		
Channels	T1, T2, T3, T4, T1-T2.		
Sensor type	Type K thermocouple probe. Type J/T/E/R/S thermocouple probe. PT 100 ohm probe * Cooperate with an 0.00385 alpha coefficient, meet DIN IEC 751.		
Resolution	0.1°C / 1°C, 0.1°F / 1°F.		
Type K	Sensor	Resolution	Accuracy
Type K	0.1 °C	-50.1 to -100.0 °C -50.0 to 999.9 °C	± (0.4 % + 1 °C) ± (0.4 % + 0.5 °C)
	1 °C	1000 to 1300 °C	± (0.4 % + 1 °C)
	0.1 °F	-58.1 to -148.0 °F -58.0 to 999.9 °F	± (0.4 % + 1.8 °F) ± (0.4 % + 1 °F)
	1 °F	1000 to 2372 °F	± (0.4 % + 2 °F)

Luminance(nit)	LED String Current(mA)	LED String Voltage(V) (Tolerance : ± 2.2V)
400	110	32.2
450	130	32.7
500	145	33.0
550	160	33.4

Our company network supports you worldwide with offices in Germany, Austria, Switzerland, the UK and the USA. For more information please contact:

Headquarters

Germany



FORTEC Elektronik AG

Augsburger Str. 2b
82110 Germering

Phone: +49 89 894450-0
E-Mail: info@forteca.de
Internet: www.forteca.de

Fortec Group Members

Austria



Distec GmbH Office Vienna

Nuschinggasse 12
1230 Wien

Phone: +43 1 8673492-0
E-Mail: info@distec.de
Internet: www.distec.de

Germany



Distec GmbH

Augsburger Str. 2b
82110 Germering

Phone: +49 89 894363-0
E-Mail: info@distec.de
Internet: www.distec.de

Switzerland



ALTRAC AG

Bahnhofstraße 3
5436 Würenlos

Phone: +41 44 7446111
E-Mail: info@altrac.ch
Internet: www.altrac.ch

United Kingdom



Display Technology Ltd.

Osprey House, 1 Osprey Court
Hichingbrooke Business Park
Huntingdon, Cambridgeshire, PE29 6FN

Phone: +44 1480 411600
E-Mail: info@displaytechnology.co.uk
Internet: www.displaytechnology.co.uk

USA



Apollo Display Technologies, Corp.

87 Raynor Avenue,
Unit 1 Ronkonkoma,
NY 11779

Phone: +1 631 5804360
E-Mail: info@apolloDisplays.com
Internet: www.apolloDisplays.com