



OUR GLOBAL
COMPETENCE
CENTRES

 APOLLO DISPLAY
TECHNOLOGIES



 DISTEC



 DISPLAY
TECHNOLOGY



Datasheet

Tianma

P1210XGF1MB00

TI-01-019



MODEL NO : P1210XGF1MB00
SPEC VERSION : V1.5
ISSUED DATE: 2021-10-25

Preliminary Specification
 Final Product Specification

Customer : _____

Approved by	Notes

TIANMA Confirmed :

Prepared by	Checked by	Approved by
Chunliang_Qian	Zhijie_Song	Xiaoxing_Ding

This technical specification is subjected to change without notice



Table of Contents

Table of Contents	2
Record of Revision.....	3
1 General Specifications.....	4
2 Input/Output Terminals	5
3 Absolute Maximum Ratings.....	7
4 Electrical Characteristics	8
5 Timing Chart.....	10
6 Optical Characteristics	20
7 Environmental / Reliability Test.....	24
8 Mechanical Drawing	25
9 Packing Drawing	26
10 Precautions For Use of LCD Modules	19
11 Incoming Inspection Standard	20



1 General Specifications

	Feature	Spec
Display Spec.	Size	12.1 inch
	Resolution	1024(RGB) x 768
	Technology Type	SFT
	Pixel Configuration	R.G.B. Vertical Stripe
	Pixel Pitch (mm)	0.240 (H) × 0.240 (V)
	Display Mode	Transmissive, Normally Black
	Surface Treatment(Up Polarizer)	HC
	Viewing Direction	All direction
Mechanical Characteristics	LCM (W x H x D) (mm)	260.5x203x9.5
	Active Area(mm)	245.76*184.32
	With /Without TSP	Without Touch Screen
	Matching Connection Type	FI-SEB20P-HFE
	Weight (g)	(550g)
Electrical Characteristics	Interface	1port LVDS 8bit / 6-bit
	Color Depth	16.7M&262K

Note 1: Viewing direction for best image quality is different from TFT definition, there is a 180 degree shift.

Note 2 : Requirements on Environmental Protection: Q/S0002

Note 3 : LCM weight tolerance : +/- 5%



2 Input/Output Terminals

2.1 TFT LCD Panel (CN1)

Connector type: JAE FI-SEB20P-HFE

Pin No.	Symbol	Signal	Input data signal: 8-bit		Input data signal: 6-bit	Remarks
			MAP A	MAP B		
1	A	D3+	Pixel data	R0-R1,G0-G1,B0-B1	R6-R7,G6-G7,B6-B7	-
	B	GND	Ground	-		Ground
2	A	D3-	Pixel data	R0-R1,G0-G1,B0-B1	R6-R7,G6-G7,B6-B7	-
	B	GND	Ground	-		Ground
3	DPS	Selection of scan direction	High : Normal scan Low or Open : Reverse scan			
4	FRC	Selection of the number of colors	High		Low or Open	
5	GND	Ground	Ground			
6	CLK+	Pixel clock	Pixel clock			
7	CLK-					
8	GND	Ground	Ground			
9	D2+	Pixel data	B4-B7,DE	B2-B5,DE		
10	D2-					
11	GND	Ground	Ground			
12	D1+	Pixel data	G3-G7,B2-B3	G1-G5,B0-B1		
13	D1-					
14	GND	Ground	Ground			
15	D0+	Pixel data	R2-R7,G2	R0-R5,G0		
16	D0-					
17	GND	Ground	Ground			
18	MSL	Selection of LVDS input map	Low(Note1)	High or Open	Low(Note2)	
19	VCC	Power supply	Power supply			
20	VCC					

Note1: FRC is high

Note2: FRC is low

Note3: Detail can refer to Page 13~14

**2.1 Backlight (CN2)****Connector type: SM10B-SHLS-TF(LF)**

No	Symbol	I/O	Description	Remarks
1	Vi	P	Converter input voltage	
2	Vi	P	Converter input voltage	
3	Vi	P	Converter input voltage	
4	Vi	P	Converter input voltage	
5	V _{GND}	P	Converter ground	
6	V _{GND}	P	Converter ground	
7	V _{GND}	P	Converter ground	
8	V _{GND}	P	Converter ground	
9	EN	I	Enable pin	Default L(Note1)
10	PWM	I	Backlight Adjust	Default H(Note2)

I/O definition:

I----Input O----Output I/O----Input/Output P----Power/Ground N—No Connect

Note1: The circuit diagram of PWM on LCM is as follows

Note2: The circuit diagram of EN on LCM is as follows

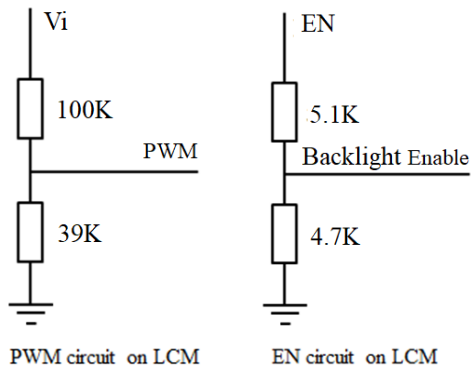



3 Absolute Maximum Ratings

Parameter		Symbol	Rating	Unit	Remarks	
Power supply voltage	LCD panel signal processing board	VCC	-0.5 to +5.0	V	Ta= 25°C	
	LED driver	Vi	9V to 28V			
Input voltage for signals	Logic Input Voltage	Low level	VIL	0 to 0.3VCC		V
		High level	ViH	0.7VCC to VCC		
	LED driver	PWM	TBD to +(5.5)	V		
		EN	TBD to (15)			
Inrush current		Irush	-	A		
Storage temperature		Tst	-40 to +90	°C		-
Operating temperature	Front surface	TopF	-30 to +80	°C		Note1
	Rear surface	TopR	-30 to +80	°C		Note2
Relative humidity Note4		RH	≤ 95	%	Ta ≤ 40°C	
			≤ 85	%	40°C < Ta ≤ 50°C	
			≤ 55	%	50°C < Ta ≤ 60°C	
			≤ 36	%	60 < Ta ≤ 70°C	
			≤ 24	%	70 < Ta ≤ 80°C	
Absolute humidity Note3		AH	≤ 70 Note4	g/m ³	Ta = 80°C	

Note1: Measured at LCD panel surface (including self-heat)

Note2: Measured at LCD module's rear shield surface (including self-heat)

Note3: No condensation

Note4: Water amount at Ta= 80°C and RH= 24%



4 Electrical Characteristics

4.1 Driving TFT LCD Panel

(Ta= 25°C)

Parameter	Symbol	min.	typ.	max.	Unit	Remarks	
Power supply voltage	VCC	(3.2)	3.3	(3.4)	V	-	
Power supply current	ICC	-	(TBD) Note1	(TBD) Note2	mA	at VCC= 3.3V	
Permissible ripple voltage	VRPC	-	-	100	mVp-p	for VCC	
Differential input threshold voltage	High	VTH	-	-	(+100)	mV	at VCM= 1.2 V Note3
	Low	VTL	(-100)	-	-		
Input voltage for DPS,FRC and MSL signal	High	VFH1	(0.7VCC)	-	(VCC)	V	CMOS level
	Low	VFL1	0	-	0.3VCC		
Input current for DPS,FRC and MSL signal	High	IFH1	-	-	(-300)	μA	-
	Low	IFL1	(-300)	-	-		

Note1: Checkered flag pattern [by IEC 61747-6]

Note2: Pattern for maximum current

Note3: Common mode voltage for LVDS receiver

4.2 Driving Backlight

(Ta= 25°C)

Parameter	Symbol	min.	typ.	max.	Unit	Remarks	
Power supply voltage	Vi	(11.2)	12.0	(12.8)	V	Note1	
Power supply current Note2	Ii	-	192 (TBD)	(TBD) Note3	mA	Note4	
Permissible ripple voltage	VRPD	-	-	200	mVp-p	for VDD	
Input voltage for PWM signal	High	VDFH1	(1.2)	-	(5)	V	-
	Low	VDFL1	0	-	(0.35)	V	
Input voltage for EN signal	High	VDFH2	TBD	(12)	TBD	V	-
	Low	VDFL2	0	-	(1.4)	V	
PWM frequency	f _{PWM}	(200)	-	(10K)	Hz	Note5, Note6	
PWM duty ratio	DR _{PWM}	(5%)	-	(100)	%	Note7	
PWM pulse width	t _{PWH}	TBD	-	-	μs		
LED Life Time	LT	-	50000	-	Hrs	Note8	

Note1:When designing of the power supply, take the measures for the prevention of surge voltage.

Note2:The power supply lines (Vi and GND) may have ripple voltage during luminance control of LED. There is the possibility that the ripple voltage produces acoustic noise and signal wave noise in audio circuit and so on. Put a capacitor between the power supply

The information contained herein is the exclusive property of SHANGHAI TIANMA MICRO-ELECTRONICS Corporation, and shall not be distributed, reproduced, or disclosed in whole or in part without prior written permission of SHANGHAI TIANMA MICRO-ELECTRONICS Corporation.



lines (Vi and GND) to reduce the noise if necessary.

Note3: This value excludes peak current such as overshoot current.

Note4: At the maximum luminance control

Note5: A recommended f_{PWM} value is as follows.

$$f_{PWM} = \frac{2n-1}{4} \times f_V$$

(n = integer, f_V = frame frequency of LCD module)

Note6: Depending on the frequency used, some noise may appear on the screen, please conduct a thorough evaluation.

Note7: The recommended PWM frequency is 200Hz to 10kHz, but the LED current cannot be 100% proportional to duty cycle, especially for high frequency and low duty ratio.

While the EN signal is high, do not set the tPWH (PWM pulse width) is less than 0.1 μ s. It may cause abnormal working of the backlight. In this case, turn the backlight off and then on again by EN signal.

Note8: Optical performance should be evaluated at Ta=25 $^{\circ}$ C only.

If LED is driven by high current, high ambient temperature & humidity condition. The life time of LED will be reduced.

Operating life means brightness goes down to 50% of initial brightness.

Typical operating life time is estimated data.



4.3 Block Diagram

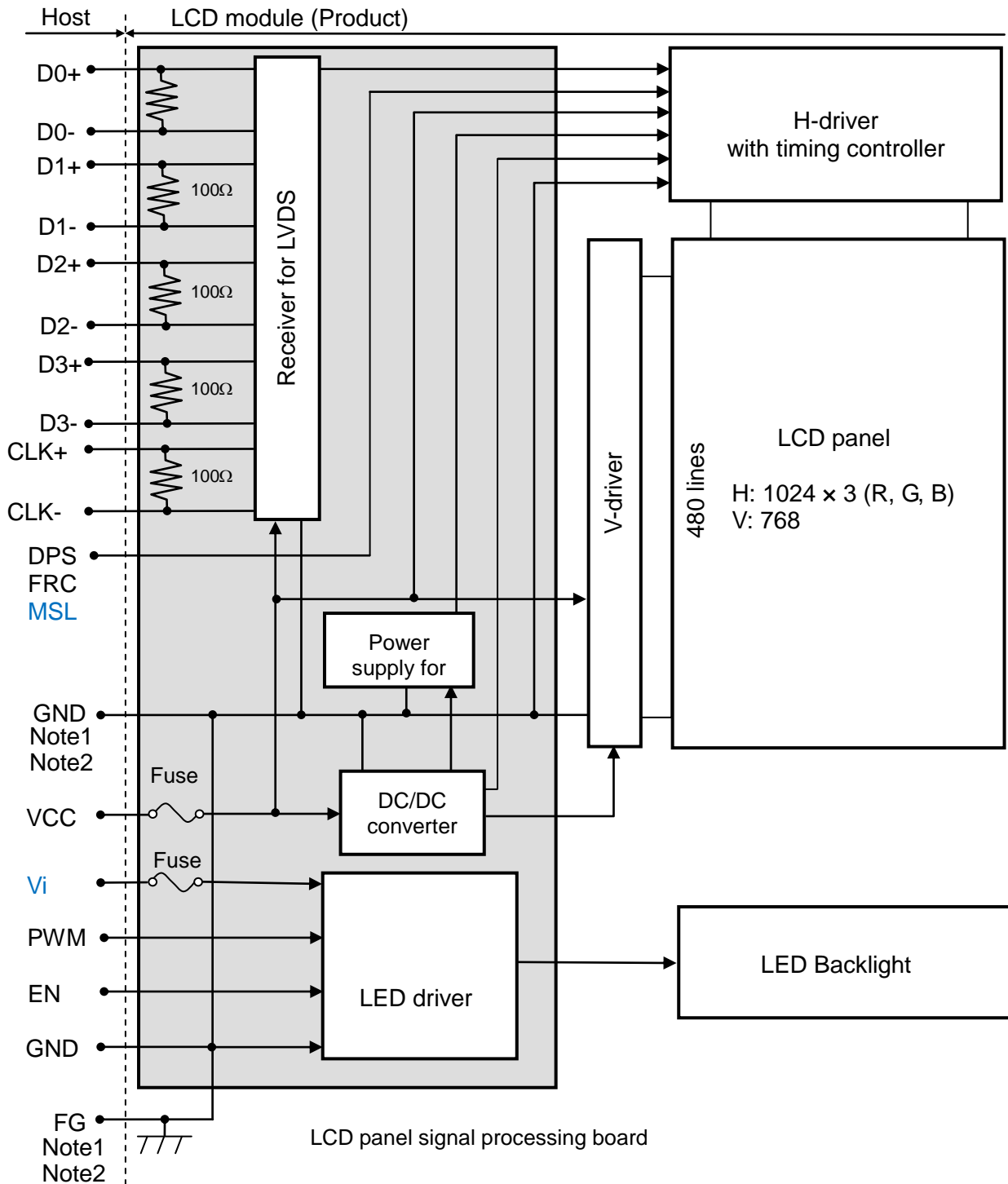

Note1: GND (Signal ground) is connected to FG (Frame ground) in the LCD module
Note2: GND and FG must be connected to customer equipment's ground, and it is recommended that these grounds to be connected together in customer equipment.



4.4 Fuse

Parameter	Fuse		Rating	Fusing characteristics	Remarks
	Type	Supplier			
VCC	(FCC16152ABT P)	KAMAYA	1.5A	250%/5s max	Note1
			36V		
Vi	(FCC16202ABT P)	KAMAYA.	2A		
			36 V		

Note1: The power supply's rated current must be more than the fusing current. If it is less than the fusing current, the fuse may not blow in a short time, and then nasty smell, smoke and so on may occur.



5 Timing Chart

5.1 Timing Characteristics

Parameter		Symbol	min.	typ.	max.	Unit	Remarks	
CLK	Frequency	1/tc	(50.34)	50.66	(65.34)	MHz	19.739ns (typ.)	
DE	Horizontal	Cycle	th	-	21.477	-	μs	46.561 kHz (typ.)
				1084	1,088	1214	CLK	
	Display period		thd	1024			CLK	-
	Vertical (One frame)	Cycle	tv	-	16.666	-	ms	60.0Hz (typ.)
			774	776	897	H		
Display period		tvd	768			H	-	

Note1: Definition of parameters is as follows.

$$t_c = 1\text{CLK}, t_h = 1\text{H}$$

Note2: See the data sheet of LVDS transmitter.

Note3: Vertical cycle (tv) should be specified in integral multiple of Horizontal cycle (th).

5.2 Input signal timing chart

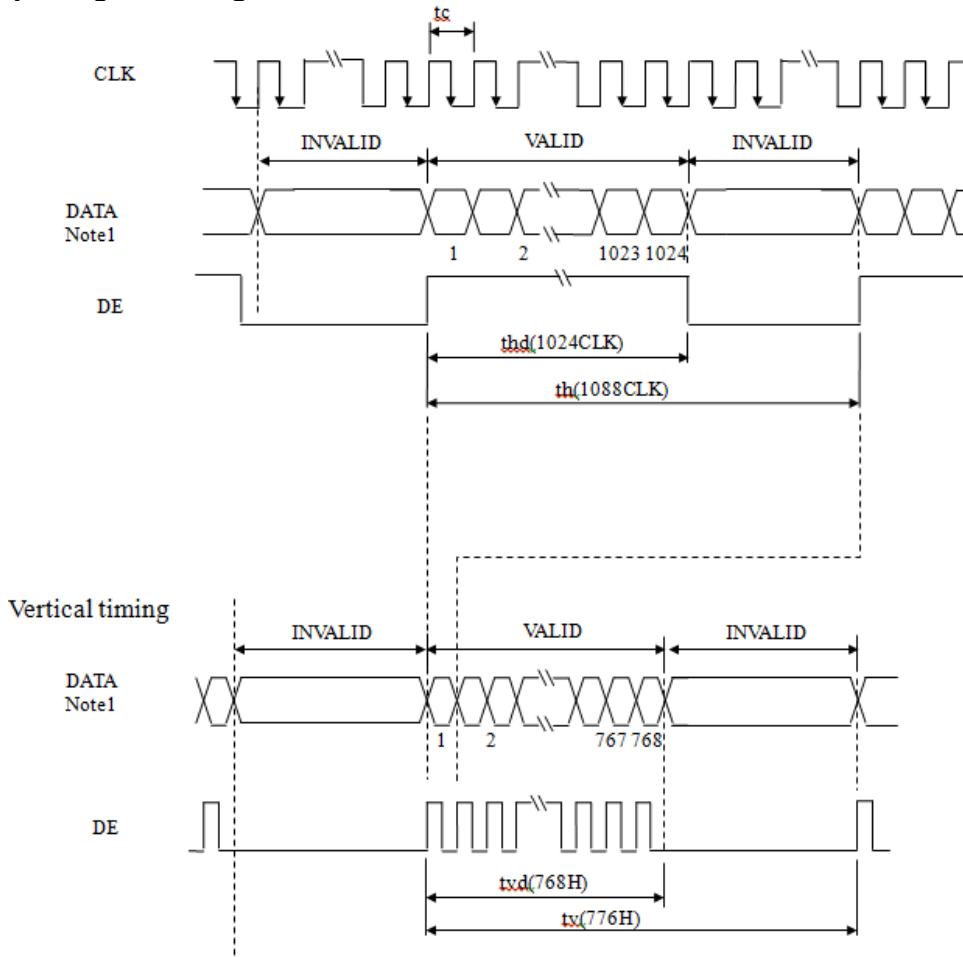

Note1: DATA = R0-R7, G0-G7, B0-B7



5.3 LVDS data input format

Input data signal: 8-bit

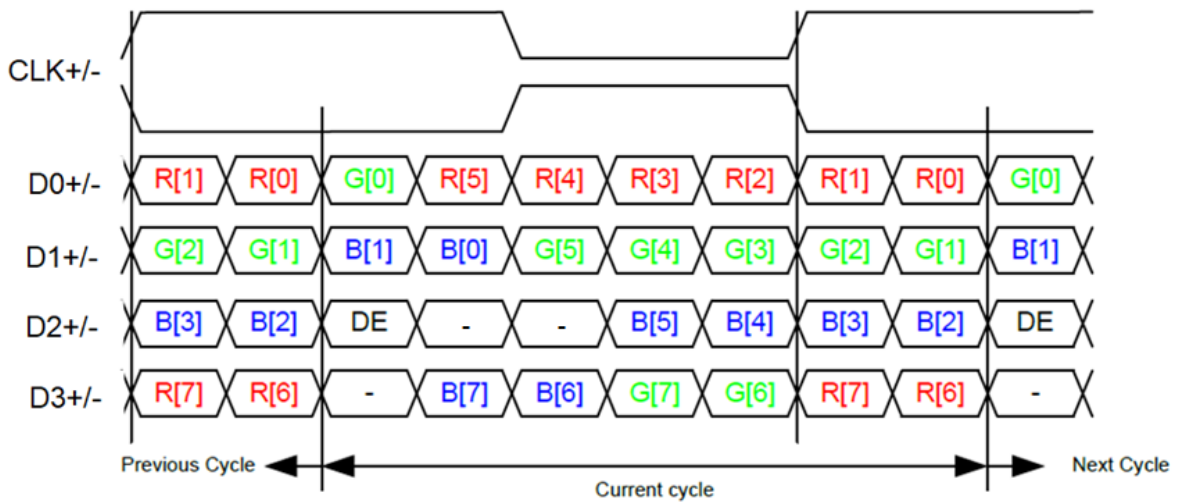

VESA (MAP B)format

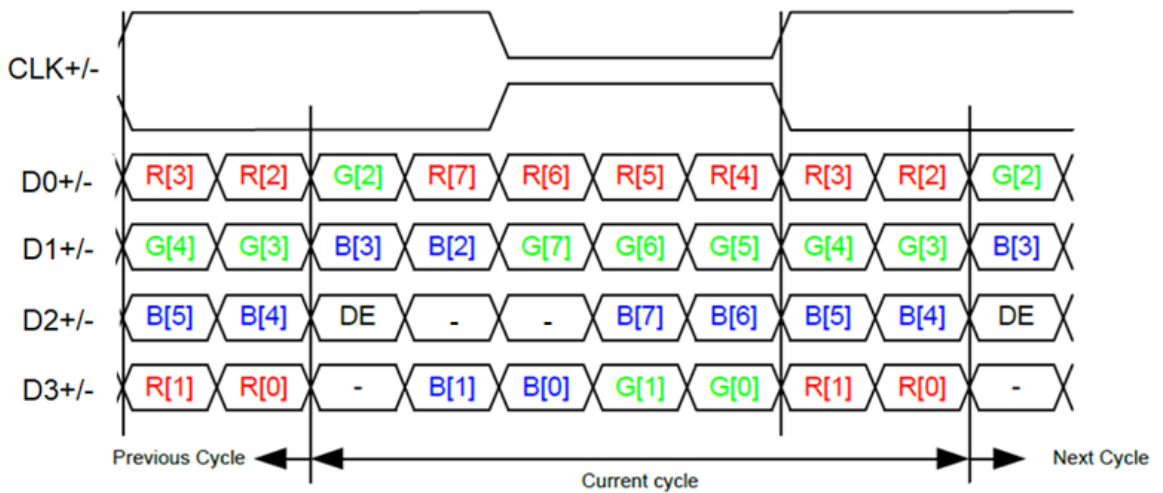

JEIDA (MAP A)format

Note1: LSB (Least Significant Bit) – R0, G0, B0; MSB (Most Significant Bit) – R7, G7, B7

Note2: Twist pair wires with 100Ω (Characteristic impedance) should be used between LCD panel signal processing board and LVDS transmitter.

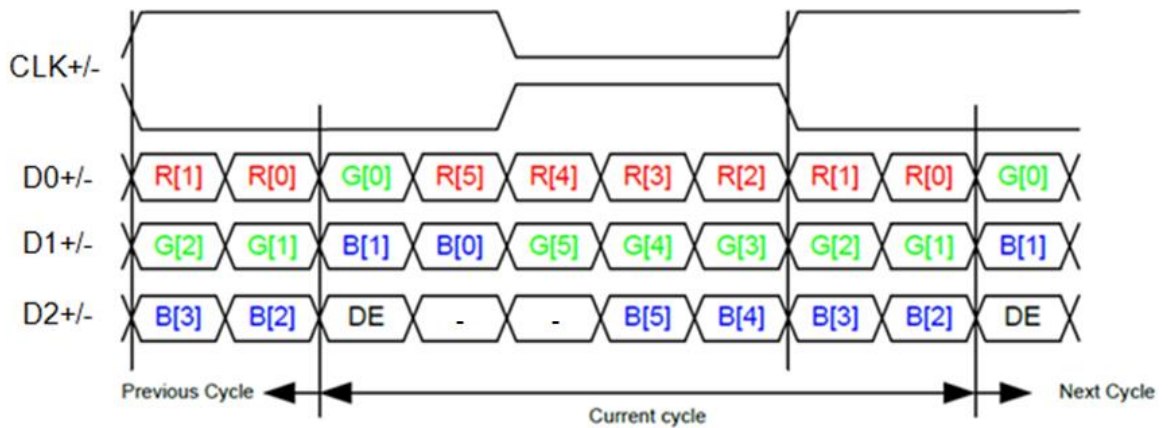
**Input data signal: 6-bit**

Note1: LSB (Least Significant Bit) – R0, G0, B0 MSB (Most Significant Bit) – R7, G7, B7

Note2: Twist pair wires with 100Ω (Characteristic impedance) should be used between LCD panel signal processing board and LVDS transmitter.

5.4 LVDS Rx AC SPEC

Parameter	Symbol	Min.	Typ.	Max.	Unit	Condition
Clock frequency	RXFCLK	10	-	110	MHz	
1 data bit time	UI	1/7	1/RXFCLK			
Position 1	Rspos1	-0.2	0	0.2	UI	
Position 2	Rspos2	0.8	1	1.2	UI	
Position 3	Rspos3	1.8	2	2.2	UI	
Position 4	Rspos4	2.8	3	3.2	UI	
Position 5	Rspos5	8	4	4.2	UI	
Position 6	Rspos6	4.8	5	5.2	UI	
Position 7	Rspos7	5.8	6	6.2	UI	
Input data skew margin	TRSKM	-	-	0.2	UI	VID =100mV RXVCM=1.2V RXFCLK=75MHz
Clock high time	TLVCH	-	4/(7*RXFCLK)	-	ns	
Clock low time	TLVCL	-	3/(7*RXFCLK)	-	ns	
PLL wake-up time	TenPLL	-	-	150	us	

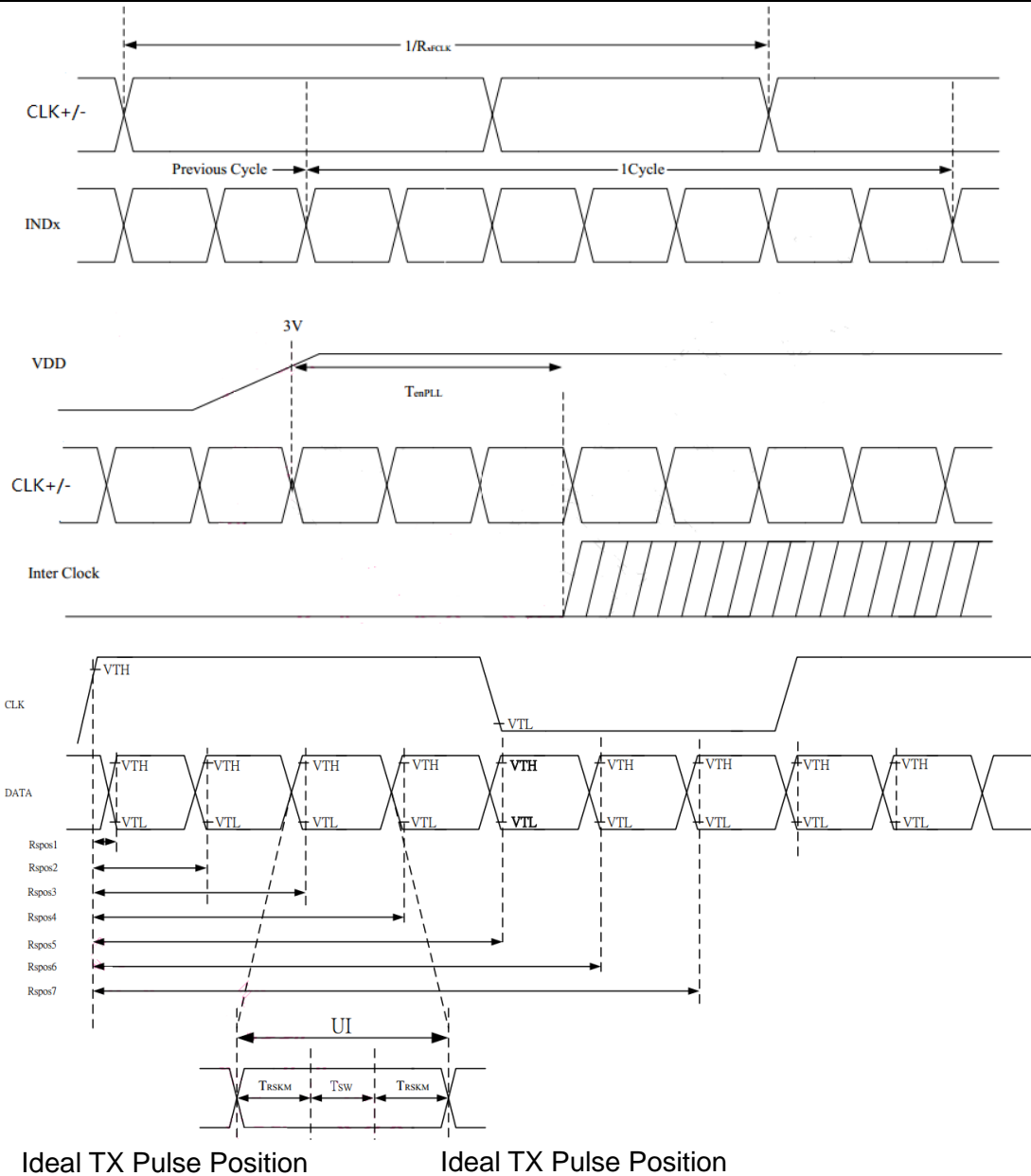

TRSKM: Receiver strobe margin
 Tsw : Strobe width (internal data sampling window)
 $VTH=R_{xvcm}+|VID|/2$, $VTL=R_{xvcm}-|VID|/2$



5.5 Display Colors and Input Data Signals

5.5.1 16,777,216 colors

This product can display equivalent of 16,777,216 colors with 256 gray scales (FRC:High). Also the relation between display colors and input data signals is as follows.

Display colors		Data signal (0: Low level, 1: High level)																							
		R7	R6	R5	R4	R3	R2	R1	R0	G7	G6	G5	G4	G3	G2	G1	G0	B7	B6	B5	B4	B3	B2	B1	B0
Basic Colors	Black	0	0	0	0	0	0	0	0	0	0	0	0	0	0	0	0	0	0	0	0	0	0	0	0
	Blue	0	0	0	0	0	0	0	0	0	0	0	0	0	0	0	0	1	1	1	1	1	1	1	1
	Red	1	1	1	1	1	1	1	1	0	0	0	0	0	0	0	0	0	0	0	0	0	0	0	0
	Magenta	1	1	1	1	1	1	1	1	0	0	0	0	0	0	0	0	1	1	1	1	1	1	1	1
	Green	0	0	0	0	0	0	0	0	1	1	1	1	1	1	1	1	0	0	0	0	0	0	0	0
	Cyan	0	0	0	0	0	0	0	0	1	1	1	1	1	1	1	1	1	1	1	1	1	1	1	1
	Yellow	1	1	1	1	1	1	1	1	1	1	1	1	1	1	1	1	0	0	0	0	0	0	0	0
	White	1	1	1	1	1	1	1	1	1	1	1	1	1	1	1	1	1	1	1	1	1	1	1	1
Red gray scale	Black	0	0	0	0	0	0	0	0	0	0	0	0	0	0	0	0	0	0	0	0	0	0	0	0
		0	0	0	0	0	0	0	1	0	0	0	0	0	0	0	0	0	0	0	0	0	0	0	0
	dark	0	0	0	0	0	0	1	0	0	0	0	0	0	0	0	0	0	0	0	0	0	0	0	0
	↑																								
	↓																								
	bright	1	1	1	1	1	1	0	1	0	0	0	0	0	0	0	0	0	0	0	0	0	0	0	0
Red	1	1	1	1	1	1	1	0	0	0	0	0	0	0	0	0	0	0	0	0	0	0	0	0	
Green gray scale	Black	0	0	0	0	0	0	0	0	0	0	0	0	0	0	0	0	0	0	0	0	0	0	0	0
		0	0	0	0	0	0	0	0	0	0	0	0	0	0	0	1	0	0	0	0	0	0	0	0
	dark	0	0	0	0	0	0	0	0	0	0	0	0	0	0	1	0	0	0	0	0	0	0	0	0
	↑																								
	↓																								
	bright	0	0	0	0	0	0	0	0	1	1	1	1	1	1	0	1	0	0	0	0	0	0	0	0
Green	0	0	0	0	0	0	0	0	1	1	1	1	1	1	1	0	0	0	0	0	0	0	0	0	
Blue gray scale	Black	0	0	0	0	0	0	0	0	0	0	0	0	0	0	0	0	0	0	0	0	0	0	0	0
		0	0	0	0	0	0	0	0	0	0	0	0	0	0	0	0	0	0	0	0	0	0	0	1
	dark	0	0	0	0	0	0	0	0	0	0	0	0	0	0	0	0	0	0	0	0	0	0	1	0
	↑																								
	↓																								
	bright	0	0	0	0	0	0	0	0	0	0	0	0	0	0	0	0	1	1	1	1	1	1	0	1
Blue	0	0	0	0	0	0	0	0	0	0	0	0	0	0	0	0	1	1	1	1	1	1	1	0	



5.5.2 262,144colors

This product can display equivalent of 262,144 colors with 64 gray scales (FRC:Low). Also the relation between display colors and input data signals is as follows.

Display colors		Data signal (0: Low level, 1: High level)																	
		R5	R4	R3	R2	R1	R0	G5	G4	G3	G2	G1	G0	B5	B4	B3	B2	B1	B0
Basic colors	Black	0	0	0	0	0	0	0	0	0	0	0	0	0	0	0	0	0	0
	Blue	0	0	0	0	0	0	0	0	0	0	0	0	1	1	1	1	1	1
	Red	1	1	1	1	1	1	0	0	0	0	0	0	0	0	0	0	0	0
	Magenta	1	1	1	1	1	1	0	0	0	0	0	0	1	1	1	1	1	1
	a	0	0	0	0	0	0	1	1	1	1	1	1	0	0	0	0	0	0
	Green	0	0	0	0	0	0	1	1	1	1	1	1	1	1	1	1	1	1
	Cyan	1	1	1	1	1	1	1	1	1	1	1	1	0	0	0	0	0	0
	Yellow	1	1	1	1	1	1	1	1	1	1	1	1	1	1	1	1	1	1
White																			
Red gray scale	Black	0	0	0	0	0	0	0	0	0	0	0	0	0	0	0	0	0	0
		0	0	0	0	0	1	0	0	0	0	0	0	0	0	0	0	0	0
	dark	0	0	0	0	1	0	0	0	0	0	0	0	0	0	0	0	0	0
	↑				:						:					:			
	↓				:						:					:			
bright	1	1	1	1	0	1	0	0	0	0	0	0	0	0	0	0	0	0	
	1	1	1	1	1	0	0	0	0	0	0	0	0	0	0	0	0	0	
Red	1	1	1	1	1	1	0	0	0	0	0	0	0	0	0	0	0	0	
Green gray scale	Black	0	0	0	0	0	0	0	0	0	0	0	0	0	0	0	0	0	0
		0	0	0	0	0	0	0	0	0	0	1	0	0	0	0	0	0	0
	dark	0	0	0	0	0	0	0	0	0	1	0	0	0	0	0	0	0	0
	↑				:						:					:			
	↓				:						:					:			
bright	0	0	0	0	0	0	1	1	1	1	0	1	0	0	0	0	0	0	
	0	0	0	0	0	0	1	1	1	1	1	0	0	0	0	0	0	0	
Green	0	0	0	0	0	0	1	1	1	1	1	1	0	0	0	0	0	0	
Blue gray scale	Black	0	0	0	0	0	0	0	0	0	0	0	0	0	0	0	0	0	0
		0	0	0	0	0	0	0	0	0	0	0	0	0	0	0	0	0	1
	dark	0	0	0	0	0	0	0	0	0	0	0	0	0	0	0	0	1	0
	↑				:						:					:			
	↓				:						:					:			
bright	0	0	0	0	0	0	0	0	0	0	0	0	1	1	1	1	0	1	
	0	0	0	0	0	0	0	0	0	0	0	0	1	1	1	1	1	0	
Blue	0	0	0	0	0	0	0	0	0	0	0	0	1	1	1	1	1	1	

5.6 Display Positions

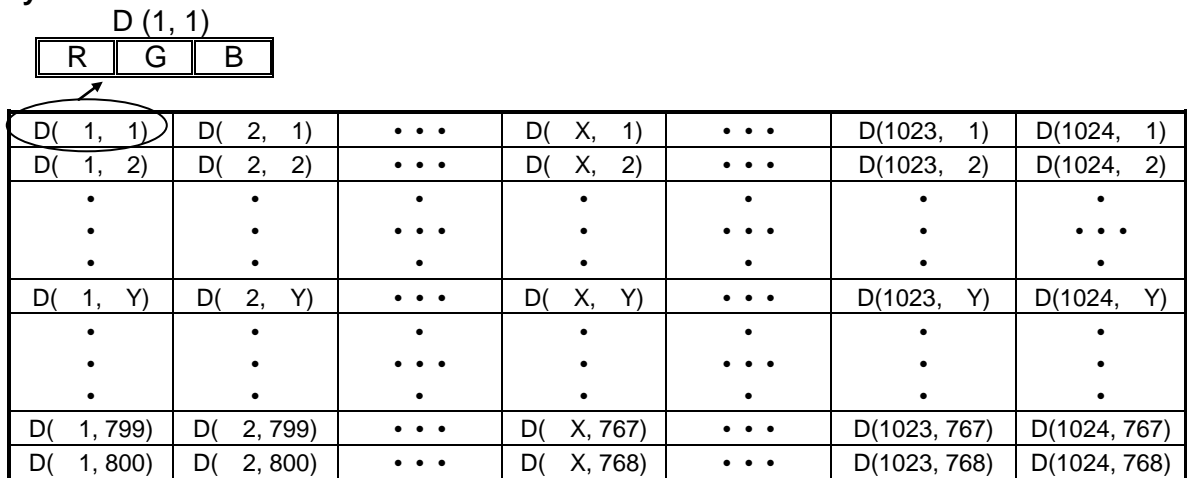

The information contained herein is the exclusive property of SHANGHAI TIANMA MICRO-ELECTRONICS Corporation, and shall not be distributed, reproduced, or disclosed in whole or in part without prior written permission of SHANGHAI TIANMA MICRO-ELECTRONICS Corporation.



5.7 Scanning Direction

The following figures are seen from a front view.

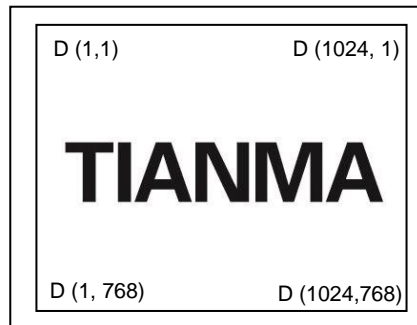

Figure1. Normal scan (DPS: High)

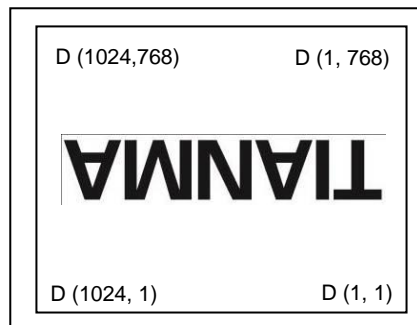
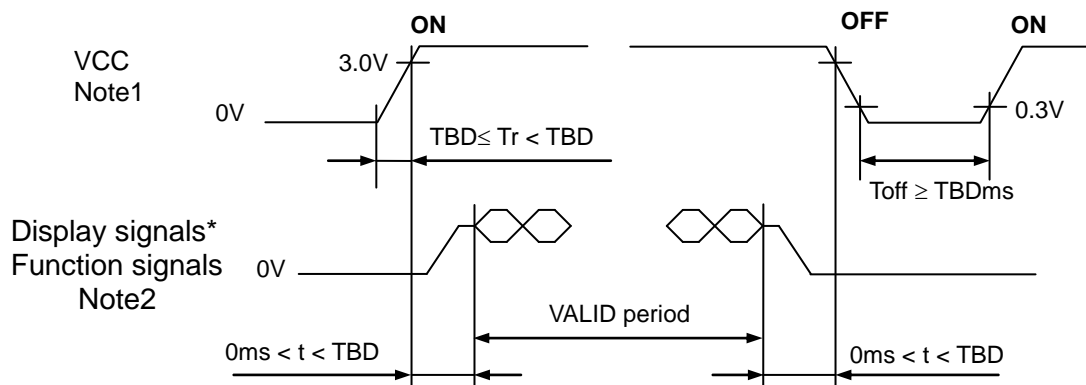

Figure2. Reverse scan (DPS: Low)

5.8 POWER SUPPLY VOLTAGE SEQUENCE

5.8.1 LCD panel signal processing board



* These signals should be measured at the terminal of 100Ω resistance.

Note1: If there is a voltage variation (voltage drop) at the rising edge of VCC below 3.0V, there is a possibility that a product does not work due to a protection circuit.

Note2: Display signals (D0+/-, D1+/-, D2+/- and CLK+/-) and function signals (DPS) must be set to Low or High-impedance, except the VALID period (See above sequence diagram), in order to avoid the circuitry damage.



If some of display and function signals of this product are cut while this product is working, even if the signal input to it once again, it might not work normally. If a customer stops the display and function signals, VCC also must be shut down.

5.8.2 LED Driver

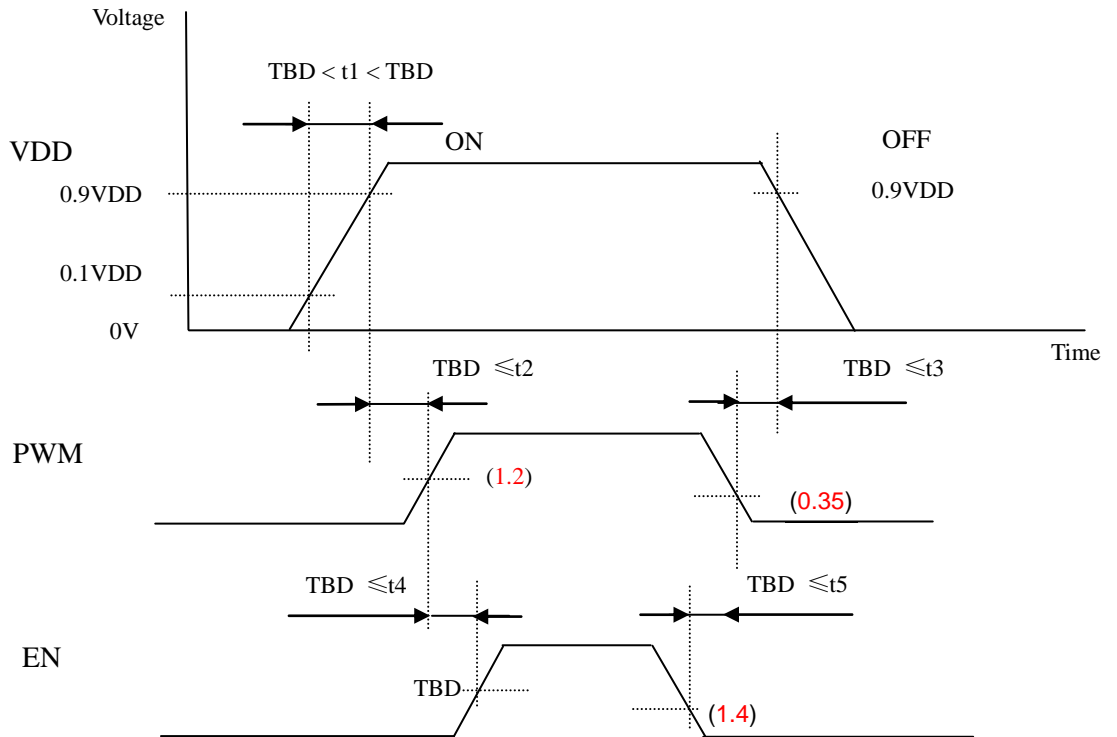



6 Optical Characteristics

6.1 Optical Specification

Ta=25°C

Item	Symbol	Condition	Min	Typ	Max	Unit	Remark		
View Angles	θT	$CR \geq 10$	70	88	-	Degree	Note 2		
	θB		70	88	-				
	θL		70	88	-				
	θR		70	88	-				
Contrast Ratio	CR	$\theta=0^\circ$	800	1000	-	-	Note1 Note3		
Response Time	T_{ON}	25°C	-	25	35	ms	Note1 Note4		
	T_{OFF}								
Chromaticity	White	Backlight is on				-	Note5 Note1		
								x	TBD
	y							TBD	
	Red							x	TBD
								y	TBD
	Green							x	TBD
								y	TBD
	Blue							x	TBD
y		TBD							
Uniformity	U	-	75	80	-	%	Note1 Note6		
NTSC	-	-	65	72	-	%	Note 5		
Luminance	L	-	TBD	500	-	cd/m ²	Note1		

Test Conditions:

1. The ambient temperature is 25±2°C.humidity is 65±7%
2. The test systems refer to Note 1 and Note 2.



Note 1: Definition of optical measurement system.

The optical characteristics should be measured in dark room. After 5 minutes operation, the optical properties are measured at the center point of the LCD screen. All input terminals LCD panel must be ground when measuring the center area of the panel.

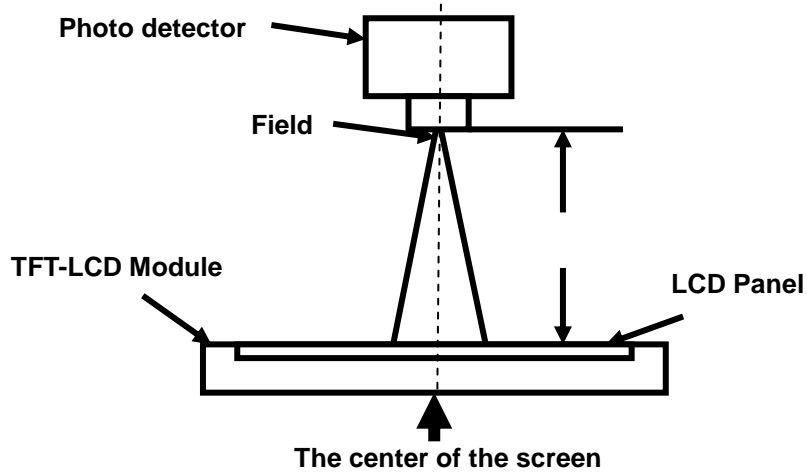

Note 2: Definition of viewing angle range and measurement system.

viewing angle is measured at the center point of the LCD by CONOSCOPE(ergo-80).

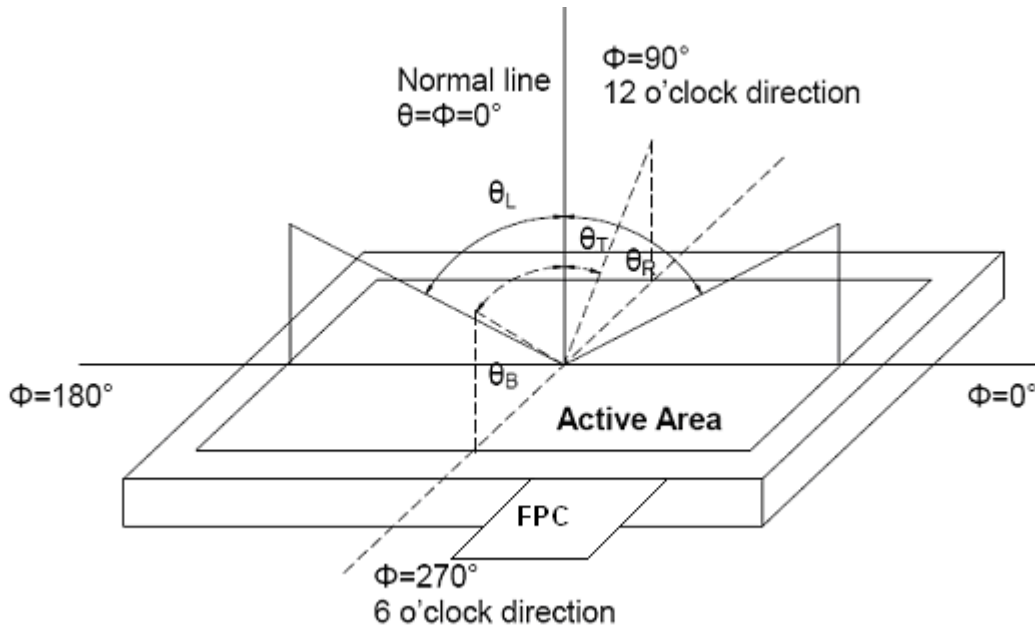

Fig. 1 Definition of viewing angle



Note 3: Definition of contrast ratio

$$\text{Contrast ratio (CR)} = \frac{\text{Luminance measured when LCD is on the "White" state}}{\text{Luminance measured when LCD is on the "Black" state}}$$

"White state": The state is that the LCD should driven by V_{white} .

"Black state": The state is that the LCD should driven by V_{black} .

V_{white} : To be determined V_{black} : To be determined.

Note 4: Definition of Response time

The response time is defined as the LCD optical switching time interval between "White" state and "Black" state. Rise time (T_{ON}) is the time between photo detector output intensity changed from 90% to 10%. And fall time (T_{OFF}) is the time between photo detector output intensity changed from 10% to 90%.

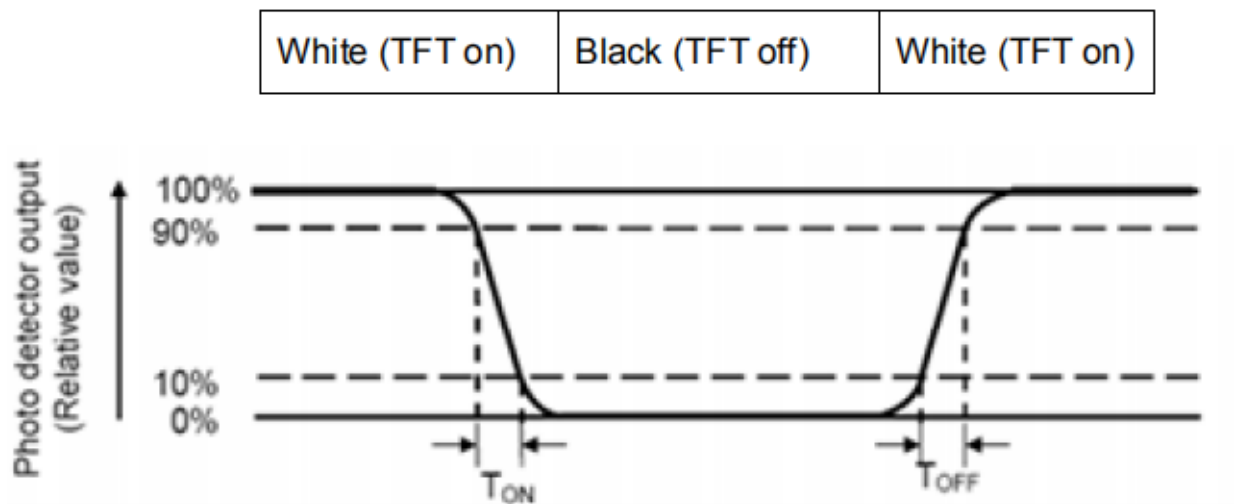

Note 5: Definition of color chromaticity (CIE1931)

Color coordinates measured at center point of LCD.

**Note 6: Definition of Luminance Uniformity**

Active area is divided into 9 measuring areas (Refer Fig. 2). Every measuring point is placed at the center of each measuring area.

$$\text{Luminance Uniformity}(U) = L_{\min} / L_{\max}$$

L-----Active area length W----- Active area width

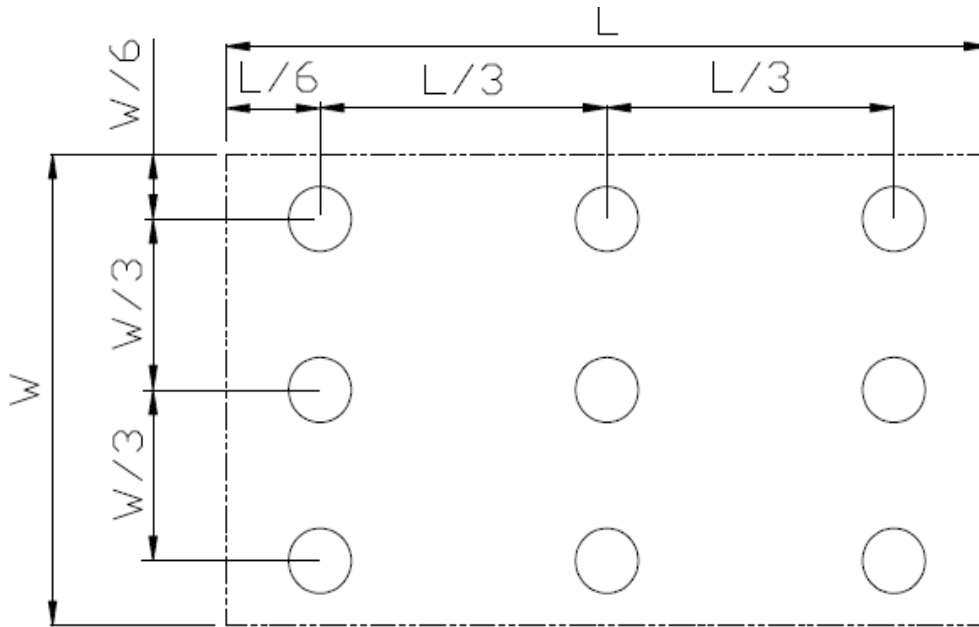

Fig. 2 Definition of uniformity

L_{\max} : The measured maximum luminance of all measurement position.

L_{\min} : The measured minimum luminance of all measurement position.

Note 7: Definition of Luminance :

Measure the luminance of white state at center point.



7 Environmental / Reliability Test

No	Test Item	Condition	Remark
1	High Temperature Operation	Ta = +80°C, 240 hours	IEC60068-2-1 GB2423.2
2	Low Temperature Operation	Ta = -30°C, 240 hours	IEC60068-2-1 GB2423.1
3	High Temperature Storage	Ta = +90°C, 240 hours	IEC60068-2-1 GB2423.2
4	Low Temperature Storage	Ta = -40°C, 240 hours	IEC60068-2-1 GB2423.1
5	High Temperature & High Humidity Operation	Ta = +60°C, 90% RH max, 240 hours	IEC60068-2-78 GB/T2423.3
6	Thermal Shock (non-operation)	-30°C 30 min~+80°C 30 min, Change time:5min, 100 Cycle	Start with cold temperature, End with high temperature, IEC60068-2-14, GB2423.22
7	ESD	C=150pF, R=330Ω, 9point/panel Air:±15Kv, 5times; Contact:±8Kv, 5times (Environment: 15°C~35°C, 30%~60%.86Kpa~106Kpa)	IEC61000-4-2 GB/T17626.2
8	Vibration Test (Non Op)	5~100HZ, 19.60m/s ² 1min/cycle 120times Per X\Y\Z	IEC60068-2-6 GB/T17626.6
9	Mechanical Shock (Non Op)	539m/s ² , 11ms 5times ±X、±Y、±Z	IEC60068-2-27 GB/T2423.5

Note1: Ts is the temperature of panel's surface.

Note2: Ta is the ambient temperature of sample.

Note3: Before cosmetic and function test, the product must have enough recovery time, at least 2 hours at room temperature.

Note 4: In the standard condition, there shall be no practical problem that may affect the display function. After the reliability test, the product only guarantees operation, but don't guarantee all of the cosmetic specification.



9 Packing Drawing



10 Precautions for Use of LCD Modules

10.1 Handling Precautions

- 10.1.1 The display panel is made of glass. Do not subject it to a mechanical shock by dropping it from a high place, etc.
- 10.1.2 If the display panel is damaged and the liquid crystal substance inside it leaks out, be sure not to get any in your mouth, if the substance comes into contact with your skin or clothes, promptly wash it off using soap and water.
- 10.1.3 Do not apply excessive force to the display surface or the adjoining areas since this may cause the color tone to vary.
- 10.1.4 The polarizer covering the display surface of the LCD module is soft and easily scratched. Handle this polarizer carefully.
- 10.1.5 If the display surface is contaminated, breathe on the surface and gently wipe it with a soft dry cloth. If still not completely clear, moisten cloth with one of the following solvents:
 - Isopropyl alcohol
 - Ethyl alcoholSolvents other than those mentioned above may damage the polarizer. Especially, do not use the following:
 - Water
 - Ketone
 - Aromatic solvents
- 10.1.6 Do not attempt to disassemble the LCD Module.
- 10.1.7 If the logic circuit power is off, do not apply the input signals.
- 10.1.8 To prevent destruction of the elements by static electricity, be careful to maintain an optimum work environment.
 - 10.1.8.1 Be sure to ground the body when handling the LCD Modules.
 - 10.1.8.2 Tools required for assembly, such as soldering irons, must be properly ground.
 - 10.1.8.3 To reduce the amount of static electricity generated, do not conduct assembly and other work under dry conditions.
 - 10.1.8.4 The LCD Module is coated with a film to protect the display surface. Be care when peeling off this protective film since static electricity may be generated.

10.2 Storage Precautions

- 10.2.1 When storing the LCD modules, avoid exposure to direct sunlight or to the light of fluorescent lamps.
- 10.2.2 The LCD modules should be stored under the storage temperature range. If the LCD modules will be stored for a long time, the recommend condition is:
Temperature : 0°C ~ 40°C Relatively humidity: ≤80%
- 10.2.3 The LCD modules should be stored in the room without acid, alkali and harmful gas.

10.3 Transportation Precautions

The LCD modules should be no falling and violent shocking during transportation, and also should avoid excessive press, water, damp and sunshine.



11.DEFECT CRITERIA

11.1.1 Display specifications

(Note1)

Defect pattern	Condition			Criteria
Line defect	Display of black , white, red, green, blue			0line
Bright dots Note2, Note3	Red + Green + Blue			≤ 3dots
	Close defect dots Note5	0mm < D ≤ 15mm Note7		Same color and different color 0set
	Linked defect dots Note6	D= 0mm Note7	2 defect dots	Same color 0set
			3 defect dots or more	Different color ≤ 1set
Dark dots Note2, Note4	Red + Green + Blue			≤ 3dots
	Close defect dots Note5	0mm < D ≤ 15mm Note7		Same color and different color 0set
	Linked defect dots Note6	D= 0mm Note7	2 defect dots	Same color and different color 0set
			3 defect dots or more	Same color and different color 0set
Between Bright dots and Dark dots	Close defect dots Note5	0mm < D ≤ 15mm Note7		Same color and different color Allowed
	Linked defect dots Note6	D= 0mm Note7	2 defect dots	Same color and different color Allowed
			3 defect dots or more	Same color and different color 0set
Total	Bright dots + Dark dots			≤ 6dots

Note1: Inspection conditions are as follows.

Temperature	25 ± 5°C
Inspection viewing distance	20cm (The distance between the inspector's eye and screen.)
Inspection direction	0° ≤ θR ≤ 20°, 0° ≤ θL ≤ 20°
	0° ≤ θU ≤ 20°
Inspection illumination	60lx (at a display surface)

Note2: See "The common inspection specifications of LCD module product (DOD-PE-16097)" for the definitions.

Note3: Inspection display patterns for Bright dots are referred to "The common inspection specifications of LCD module product (DOD-PE-16097)".

Note4: Inspection display patterns for Dark dots are referred to "The common







inspection specifications of LCD module product (DOD-PE-16097)".

Note5: See "4.11.2 Close defect dots".





Note6: See "4.10.3 Linked defect dots".

Note7: **D** is the distance between defect dots.

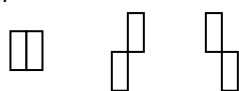

11.1.2 Close defect dots

Defect pattern	 : Bright dot  : Dark dot	Criteria
Bright dots	Same color and Different color  $0\text{mm} < \mathbf{D} \leq 15\text{mm}$	0set
Dark dots	Same color and Different color  $0\text{mm} < \mathbf{D} \leq 15\text{mm}$	
Combination of bright dot and dark dot	 $0\text{mm} < \mathbf{D} \leq 15\text{mm}$	Allowed

11.1.3 Linked defect dots

Defect pattern	 : Bright dot  : Dark dot	Criteria
2 defect dots	Same color 	0set
	Different color 	≤ 1set
	Same color and Different color 	0set
	Combination of bright dot and dark dot  Etc.	Allowed

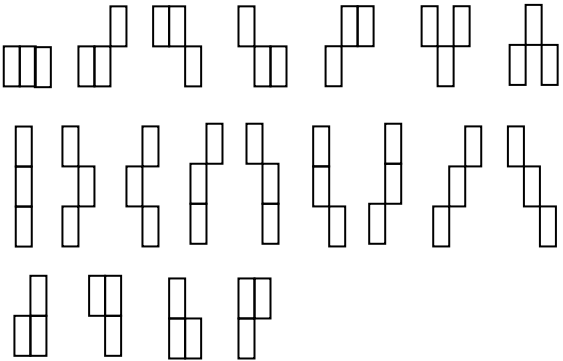
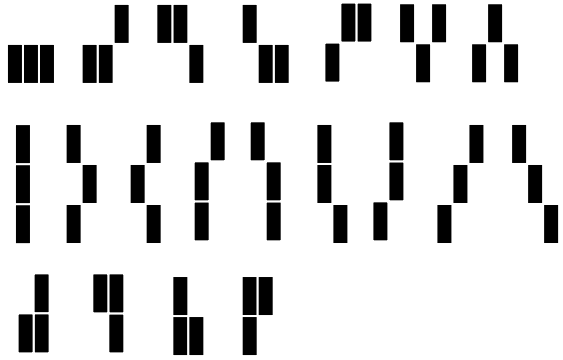
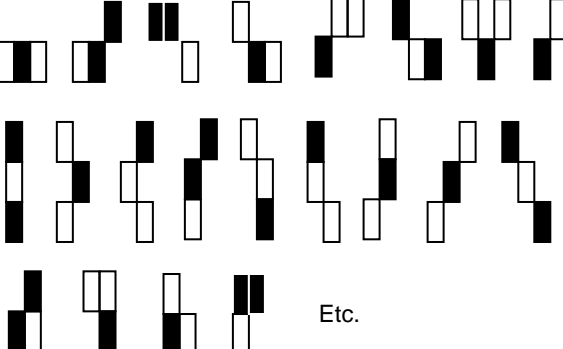

Defect pattern	 : Bright dot  : Dark dot	Criteria
<p>3 defect dots</p>	<p>Bright dot</p> 	<p>0set</p>
	<p>Dark dots</p> 	
	<p>Combination of bright dot and dark dot</p>  <p style="text-align: right; margin-right: 50px;">Etc.</p>	



11.1.4 Appearance specifications

(Note1, Note2, Note3)

Defect pattern		Condition	Criteria
Impure ingredient Stains Dust	Dot shape	$d < 0.2\text{mm}$	Allowed
		$0.2\text{mm} \leq d < 0.3\text{mm}$	$\leq 10\text{points}$
		$0.3\text{mm} \leq d \leq 0.5\text{mm}$	$\leq 3\text{points}$
		$d > 0.5\text{mm}$	0point
	Line shape	$W < 0.05\text{mm}$	Allowed
		$0.05\text{mm} \leq W \leq 0.1\text{mm}$	$L < 0.7\text{mm}$
$0.7\text{mm} \leq L \leq 1.0\text{mm}$			0point
$W > 0.1\text{mm}$			
Bubbles, Wrinkles, Dent		$d \leq 0.2\text{mm}$	Allowed
		$0.2\text{mm} < d \leq 0.5\text{mm}$	$\leq 2\text{points}$
		$d > 0.5\text{mm}$	0point
Scratch (Surface of polarizer)		$S \leq 0.2\text{mm}^2$	Allowed
		$S > 0.2\text{mm}^2$	0point

Note1: Definition of symbols is as follows.

- d: Average diameter
(This diameter is the average length of a long axis and a short axis in each defect pattern.)
- W: Width, L: Length, S: Area

Note2: Inspection conditions are as follows.

Temperature	$25 \pm 5^\circ\text{C}$
Inspection viewing distance	20cm (The distance between the inspector's eye and screen.)
Inspection direction	$0^\circ \leq \theta_R \leq 45^\circ, 0^\circ \leq \theta_L \leq 45^\circ$
	$0^\circ \leq \theta_U \leq 45^\circ, 0^\circ \leq \theta_D \leq 45^\circ$
Inspection illumination	700lx (at an inspection desk surface)

Note3: Inspection area

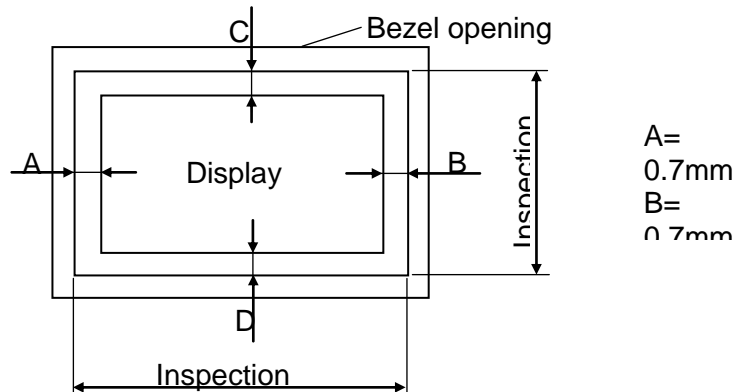

Our company network supports you worldwide with offices in Germany, Austria, Switzerland, the UK and the USA. For more information please contact:

Headquarters

Germany



FORTEC Elektronik AG

Augsburger Str. 2b
82110 Germering

Phone: +49 89 894450-0
E-Mail: info@forteca.de
Internet: www.forteca.de

Fortec Group Members

Austria



Distec GmbH Office Vienna

Nuschinggasse 12
1230 Wien

Phone: +43 1 8673492-0
E-Mail: info@distec.de
Internet: www.distec.de

Germany



Distec GmbH

Augsburger Str. 2b
82110 Germering

Phone: +49 89 894363-0
E-Mail: info@distec.de
Internet: www.distec.de

Switzerland



ALTRAC AG

Bahnhofstraße 3
5436 Würenlos

Phone: +41 44 7446111
E-Mail: info@altrac.ch
Internet: www.altrac.ch

United Kingdom



Display Technology Ltd.

Osprey House, 1 Osprey Court
Hichingbrooke Business Park
Huntingdon, Cambridgeshire, PE29 6FN

Phone: +44 1480 411600
E-Mail: info@displaytechnology.co.uk
Internet: www.displaytechnology.co.uk

USA



Apollo Display Technologies, Corp.

87 Raynor Avenue,
Unit 1 Ronkonkoma,
NY 11779

Phone: +1 631 5804360
E-Mail: info@apolloDisplays.com
Internet: www.apolloDisplays.com