



**SLD1268-E V3**  
**12.1" TFT LCD, LED Backlight 1600nits, 1024x768**

SLD1268-E is an innovative sunlight readable, LED backlight LCD display. It provides LCD panel with specific ratios for digital signage, public transportation, exhibition hall, department store, vending machine and industrial applications. Incorporating with AD. Control board and backlight design, it is high brightness and sunlight readable panel, can display high-quality video with energy-efficient.

**Key Features**

- High Brightness 1600 nits
- Sunlight Readable
- Wide Operation Temperature
- LED Backlight
- Low Power Consumption
- Slim Bezel
- BL MTBF: 100,000 hours



**Specifications**

<b>Model Name</b>	<b>SLD1268-E V3</b>
<b>Description</b>	12.1" TFT LCD, 1600 nits LED Backlight, 1024x768
<b>Screen Size</b>	12.1"
<b>Display Area (mm)</b>	245.8(H) x 184.3(V)
<b>Brightness</b>	1600 cd/m <sup>2</sup>
<b>Resolution</b>	1024x768
<b>Contrast Ratio</b>	600 : 1
<b>Pixel Pitch (mm)</b>	0.24(H) x 0.24(V)
<b>Pixel Pre Inch (PPI)</b>	106
<b>Viewing Angle</b>	160 °(H),160 °(V)
<b>Color Saturation (NTSC)</b>	80%
<b>Display Colors</b>	16.2M
<b>Response Time (Typical)</b>	35ms
<b>Panel Interface</b>	LVDS
<b>AD Board Input Interface</b>	VGA, DVI
<b>Input Power</b>	DV 12V
<b>Power Consumption</b>	13.8W
<b>OSD Key</b>	4 Keys (Power Switch, Menu, +, -)
<b>OSD Control</b>	Brightness, Color, Contrast, Auto Turing, H/V Position...etc
<b>Dimensions (mm)</b>	272x205.4x36.2mm
<b>Bezel Size(U/B/L/R)</b>	9.15/8.3/12.4/10.6 mm
<b>Weight (Net)</b>	1kg
<b>Mounting</b>	75x75 mm
<b>Operating Temperature</b>	-30°C ~ 85 °C
<b>Storage Temperature</b>	-30 °C ~ 85 °C

SLD= Panel + LED Driving Board + AD Control Board + Housing

*Specifications are subject to change without notice.  
 All brands or product names are trademarks or registered trademarks of their respective companies.*

**Mechanical Drawing**



### Outline Dimensions

Unit:mm

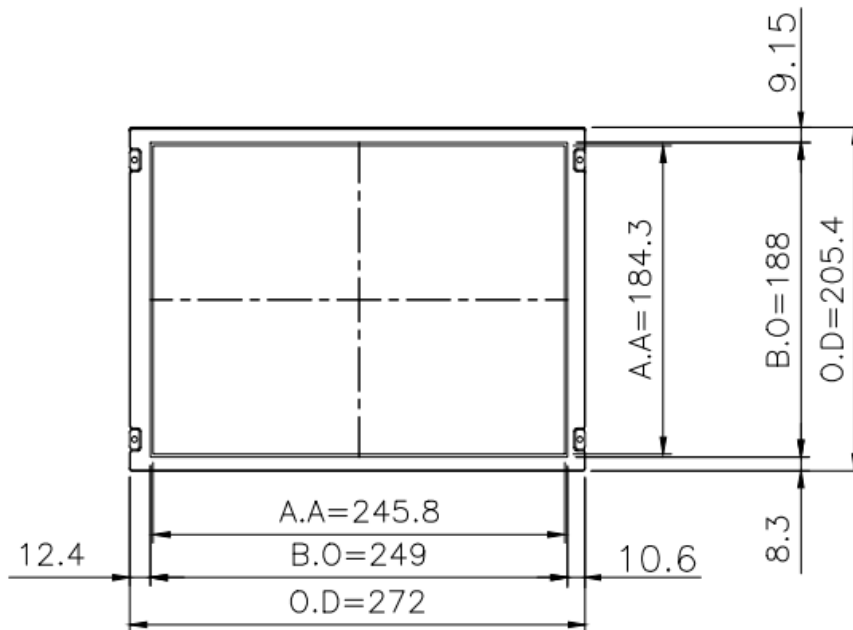
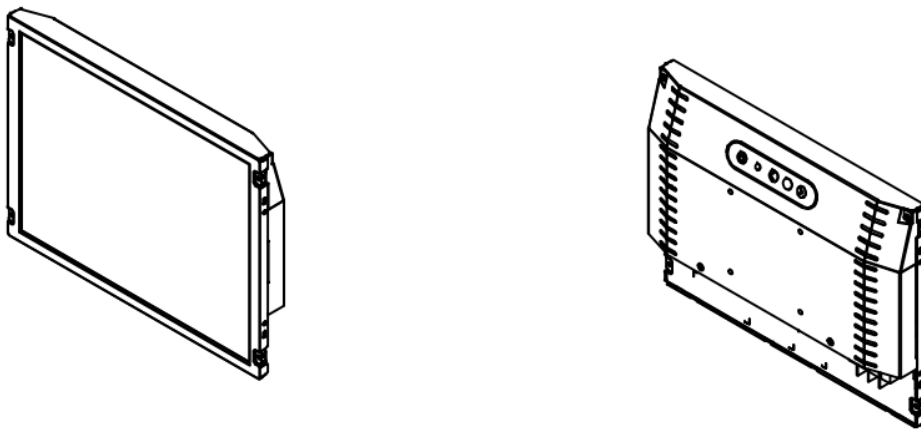

- LIGHT SENSOR
- DC 12V
- VGA
- AUDIO IN
- AUDIO OUT

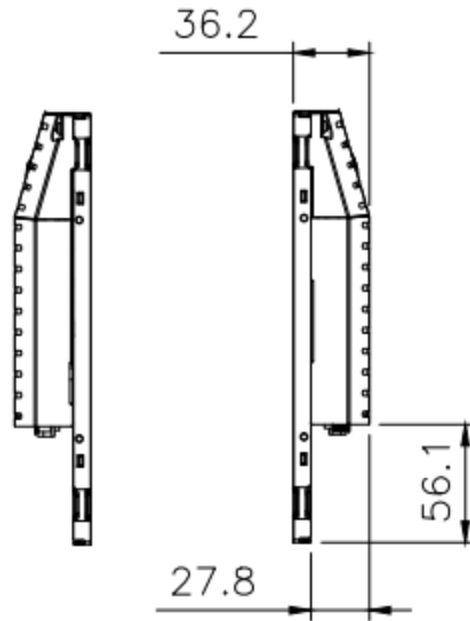

MEMBRANE 4-KEY

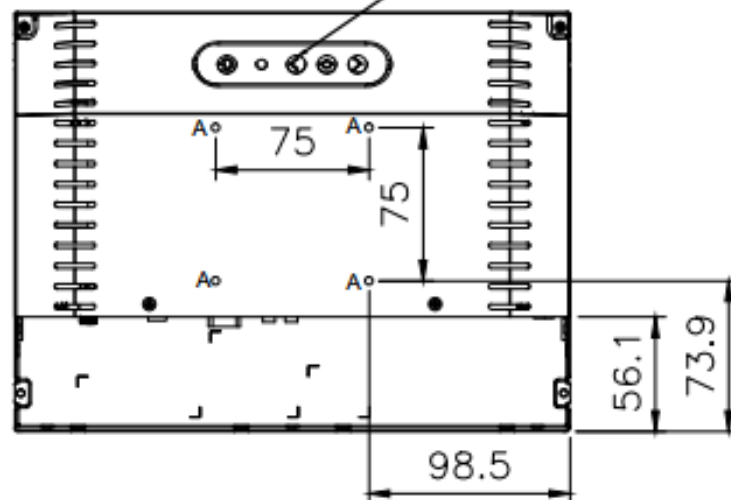

Note :

O.D. : Outline Dimension

B.O. : Bezel Opening

A.A. : LCD Active Area

A : 8-M4\_USER HOLE\_MAX\_DEPTH=5mm

### Ordering Information



Part Number	Description
<b>SLD1268-ENB-I22</b>	12.1" ,1600nits,XGA,LID12A,AD6038GA,O/B,L/S,2in 1,V03

### Optional Accessories

Part Number	Description
<b>840612051212</b>	ADAPTER,AC/DC,12V/5A,60W.Power-Din-4P,CWT.G99-ABF060F-N022.Efficiency-level-6,R
<b>810618301010</b>	CABLE.POWER.A.C.1830mm USA type
<b>810618301090</b>	CABLE.POWER.A.C.1830mm Europe type
<b>810618301050</b>	CABLE.POWER.A.C.1830mm UK type
<b>810618301170</b>	CABLE.POWER.A.C.1830mm Australia type
<b>810618301031</b>	CABLE.POWER.A.C.1830mm Japan type

### Customer request

<b>Touch</b>	PCT (Multi-Touch)
<b>Glass</b>	Tempered glass, AR coating.....