



DATA DISPLAY GROUP

Datasheet

AUO

G150XG01V4.403

UP-02-093

The information contained in this document has been carefully researched and is, to the best of our knowledge, accurate. However, we assume no liability for any product failures or damages, immediate or consequential, resulting from the use of the information provided herein. Our products are not intended for use in systems in which failures of product could result in personal injury. All trademarks mentioned herein are property of their respective owners. All specifications are subject to change without notice.

() Preliminary Specifications

(V) Final Specifications

Module	15 Inch Color TFT-LCD
Model Name	G150XG01 V4

Customer	Date
_____	_____
Checked & Approved by	
_____	_____
<p>Note: This Specification is subject to change without notice.</p>	

Approved by	Date
<i>Vito Huang</i>	<i>2013/09/09</i>
Prepared by	
<i>Elsie Kuo</i>	<i>2013/09/09</i>
<p>Audio-Video Business Unit / AU Optronics corporation</p>	

Contents

1. Operating Precautions	4
2. General Description	5
2.1 Display Characteristics.....	5
2.2 Touch Characteristics.....	6
2.3 Optical Characteristics.....	8
3. Functional Block Diagram	11
4. Absolute Maximum Ratings	12
4.1 Absolute Ratings of TFT LCD Module.....	12
4.2 Absolute Ratings of Environment.....	12
5. Electrical Characteristics	13
5.1 TFT LCD Module.....	13
5.2 Backlight Unit.....	15
6. Signal Characteristic	16
6.1 Pixel Format Image.....	16
6.2 Scanning Direction.....	16
6.3 Signal Description.....	17
6.4 The Input Data Format.....	18
6.5 Interface Timing.....	20
6.6 Power ON/OFF Sequence.....	21
7. Connector & Pin Assignment	23
7.1 TFT-LCD Signal: LVDS Interface Connector.....	23
7.2 LED Backlight Unit:.....	24
7.2 LED Backlight Unit:.....	25
LED Driver Connector.....	25
LED Driver Connector Pin Assignment.....	25
8. Reliability Test Criteria	26
9. Mechanical Characteristics	27
9.1 LCM Outline Dimension (Front View).....	27
9.2 LCM Outline Dimension (Rear View).....	28
10. Label and Packaging	29
10.1 Shipping Label (on the rear side of TFT-LCD display).....	29
10.2 Carton Package.....	29
11 Safety	30
11.1 Sharp Edge Requirements.....	30
11.2 Materials.....	30
11.3 Capacitors.....	30
11.4 National Test Lab Requirement.....	30

Record of Revision

Version and Date	Page	Old description	New Description
Rev 0.1 2011/4/11	All	First Edition	
Rev 0.2 2011/08/20	26,27		Drawing update
Rev 1.0 2012/08/06	6	Maximum Touch Points: 1 Touch Point(10 mm cover lens) 2 Touch Points(3mm cover lens)	Maximum Touch Points: 2 Touch Points Delete 1 Touch Point: 10 mm cover lens
		Support Touch Point	Delete Support Touch Point
		Total Sensing Height: Up to 10 mm	Total Sensing Height: 3mm(Note 1) Add Note 1
		Small distance between two points: 2.2mm	Small distance between two points: 22mm
	7	Figure 1	Change the title to Note 2 Delete Win CE/Vista/Linux/Android Only keep Windows 7/Windows XP
	8	Color Coordinates	Update Color Coordinates
	26,27	LCM outline drawing	Update LCM Outline drawing
	28	Label and Packaging	Update Label drawing and Packaging info
Rev 1.1 2013/02/21	6	IC Driver: Pixcir	Update IC Driver information from Pixcir to Raydium
	7	Add Note 3 & 4	Add Note3 and 4 (Stocking, Handling and Cleaning)
	7	Modify Note 1 and 2 contents	Update sensing height & windows XP information
	15	5.3.1 Touch Electrical Specification	Add Remark
	26~27	Module Drawing	Update Module drawing with new TP board
Rev. 1.2 2013/8/27	5.6.12	Display / Touch operating temperature range: -10~60 °C	Update operating temp. range to -30~85 °C
	25	Reliability test criteria: High temp. operation: 60 °C, 300 hours	Update to 85 °C, 300 hours
	25	Reliability test criteria: Low temp. operation: -10 °C, 300 hours	Update to -30 °C, 300 hours
	25	na	Add note 2
Rev. 1.3 2013/09/09	6	Wording change: Jitter	Change wording "Jitter" to "Linearity"
	6	Offset spec.	Delete offset spec.
	6	Sample rate at 10/5/1 point	Sample rate at 2/1 point
	7		Add suggest height 0.5~0.8mm in Δ_2
	7	Δ_3 : Touch sensing height: Make sure Δ_3 of your design be less than 2mm, Maximum sensing height is 2mm	Δ_3 : Touch sensing height: Suggest sensing height (Δ_3) is 2mm

1. Operating Precautions

- 1) Since front polarizer is easily damaged, please be cautious and not to scratch it.
- 2) Be sure to turn off power supply when inserting or disconnecting from input connector.
- 3) Wipe off water drop immediately. Long contact with water may cause discoloration or spots.
- 4) When the panel surface is soiled, wipe it with absorbent cotton or soft cloth.
- 5) Since the panel is made of glass, it may be broken or cracked if dropped or bumped on hard surface.
- 6) Since CMOS LSI is used in this module, take care of static electricity and insure human earth when handling.
- 7) Do not open nor modify the module assembly.
- 8) Do not press the reflector sheet at the back of the module to any direction.
- 9) In case if a module has to be put back into the packing container slot after it was taken out from the container, do not press the center of the LED Reflector edge. Instead, press at the far ends of the LED Reflector edge softly. Otherwise the TFT Module may be damaged.
- 10) At the insertion or removal of the Signal Interface Connector, be sure not to rotate nor tilt the Interface Connector of the TFT Module.
- 11) TFT-LCD Module is not allowed to be twisted & bent even force is added on module in a very short time. Please design your display product well to avoid external force applying to module by end-user directly.
- 12) Small amount of materials without flammability grade are used in the TFT-LCD module. The TFT-LCD module should be supplied by power complied with requirements of Limited Power Source (IEC60950 or UL1950), or be applied exemption.
- 13) Severe temperature condition may result in different luminance, response time.
- 14) Continuous operating TFT-LCD Module under high temperature environment may accelerate LED light bar exhaustion and reduce luminance dramatically.
- 15) The data on this specification sheet is applicable when TFT-LCD module is placed in landscape position.
- 16) Continuous displaying fixed pattern may induce image sticking. It's recommended to use screen saver or moving content periodically if fixed pattern is displayed on the screen.

2. General Description

G150XG01 V4 is a Color Active Matrix Liquid Crystal Display composed of a TFT-LCD display, a touch sensor glass, a driver circuit, and a backlight system. The screen format is intended to support XGA (1024(H) x 768(V)) screen and 16.2M (RGB 8-bits) or 262k colors (RGB 6-bits). All input signals are LVDS interface compatible. All design rules of this module can correspond to PSWG standard.

G150XG01 V4 is designed for industrial display applications.

2.1 Display Characteristics

The following items are characteristics summary on the table under 25 °C condition:

Item	Unit	Specifications
Screen Diagonal	[inch]	15
Active Area	[mm]	304.128(H) x 228.096(V)
Pixels H x V		1024x2, 768x2 (RGBW)
Pixel Pitch	[mm]	0.297 x 0.297
Pixel Arrangement		R.G.B.W. Rectangle
Display Mode		TN, Normally White
Nominal Input Voltage VDD	[Volt]	3.3 typ.
Typical Power Consumption	[Watt]	9.63 (64 Gray Bar pattern)
Weight	[Grams]	1120g (max.)
Physical Size	[mm]	326.5(H)x 253.5(V) x 15.5(D) (max.)
Electrical Interface		1 channel LVDS
Support Color		16.2M / 262K colors
Temperature Range Operating Storage (Non-Operating)	[°C] [°C]	-30 to +85 -30 to +85
RoHS Compliance		RoHS Compliance

2.2 Touch Characteristics

The following items are characteristics summary on the table under 25 °C condition:

Item	Unit	Specifications
Type of Touch Sensor		Charge-Sensing (Capacitive) Type
Panel Size	[mm]	323.5(W) x 250.5 (H) x 0.7 (T)
Sensor Active Area	[mm]	304.128 (W) x 228.096 (H)
IC Driver (Sensor)		AUO T423-1C
Channel	[ch]	X:42 Y:31
Surface hardness	[H]	7
Maximum touch points	Points	2
Touch Resolution	[ppi]	3.44
Touch Active Area	[mm]	304.128 (W) x 228.096 (H)
Touch Sensor Pitch	[mm]	7.256 (W) X 7.378 (H)
Touch Method	[mm]	Capacitance sensor
Single/Multi-points Accuracy	[mm]	+/- 2.5mm
Linearity	[mm]	+/- 2.5mm
The smallest distance between 2 points	[mm]	22mm
Sample rate at 2/1 point	[Hz]	115 HZ (1 finger) 115 HZ (2 finger)
Touch sensing height	[mm]	Up to 2mm (Note 1)
TP Controller		NXP LPC1343
Number of X / Y Channel		42 /31
Resolution X / Y	[Pixel]	1024 / 768
Power Consumption	[mWatt]	290mW(typ.)
Electrical Interface		USB2.0 Full Speed
OS Support		Win7 / WinXP (Note 2)
Operating Temperature Range	[°C]	-30 to +85
Transparency	[%]	90

Note 1:

Δ_1 : Cover Lens thickness

Δ_2 : The air gap between the cover lens and the sensor glass (suggest height 0.5~0.8mm)

Δ_3 : Touch sensing height: Suggest sensing height (Δ_3) is 2mm

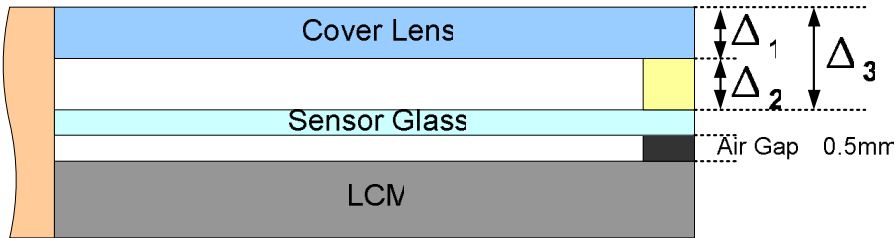

Note 2:

Except Window 7 application, the driver is necessary to be installed before operating. Available drivers are listed as below.

OS	Kernal	Driver		Remark
		USB		
		Hardware	Software	
Windows XP		X86	SP3	HID Mouse Format Only single touch
Windows 7 start		X86	Win 7 start	No driver is required

Note 3: Stocking

- Do not stack the products nor put any heavy weight on top.
- Do not shake nor drop.
- Store at the room temperature away from chemicals as damage from acid and alkali could affect the screen/ panel.

Note 4: Handling and Cleaning

- Hold by the glass edge of the product to avoid sticking dirt or scratches on the film.
- Do not pull or drag forcibly at the Tail/ FPC. Bending it may cause severe damage.
- Use 80% Alcohol mixed with 20% water and a Non-Woven Cloth to clean the screen/ panel surface. Do not sue any acids or cleaning alkali liquids as this may cause cosmetic damage.

2.3 Optical Characteristics

The optical characteristics are measured under stable conditions at 25 °C (Room Temperature):

Item	Unit	Conditions	Min.	Typ.	Max.	Note
White Luminance	[cd/m2]	100% Dimming (center point)	280	350	-	1
Uniformity	%	9 Points	75	80	-	1, 2, 3
Contrast Ratio			400	700	-	4
Cross talk	%		-	1.2	1.5	5
Response Time	[msec]	Rising	-	5.7		6
	[msec]	Falling	-	2.3		
	[msec]	Raising + Falling	-	8		
Viewing Angle	[degree] [degree]	Horizontal (Right) CR = 10 (Left)	70 70	80 80	- -	7
	[degree] [degree]	Vertical (Upper) CR = 10 (Lower)	50 70	60 80	- -	
Color / Chromaticity Coordinates (CIE 1931)		Red x	0.575	0.625	0.675	
		Red y	0.3	0.350	0.4	
		Green x	0.291	0.341	0.391	
		Green y	0.539	0.589	0.639	
		Blue x	0.101	0.151	0.201	
		Blue y	0.029	0.079	0.129	
		White x White y	0.263 0.279	0.313 0.329	0.363 0.379	
Color Gamut	%		-	60	-	
Gamma Value			-	2.2	-	8

Note 1: Measurement method

Equipment Pattern Generator, Power Supply, Digital Voltmeter, Luminance meter (SR_3 or equivalent)

Aperture 1□with 50cm viewing distance

Test Point Center

Environment < 1 lux

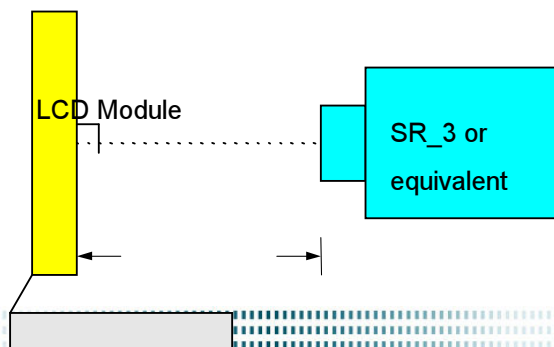

Note 2: Definition of 9 points position (Display active area : 304.128(H) x 228.096(V))

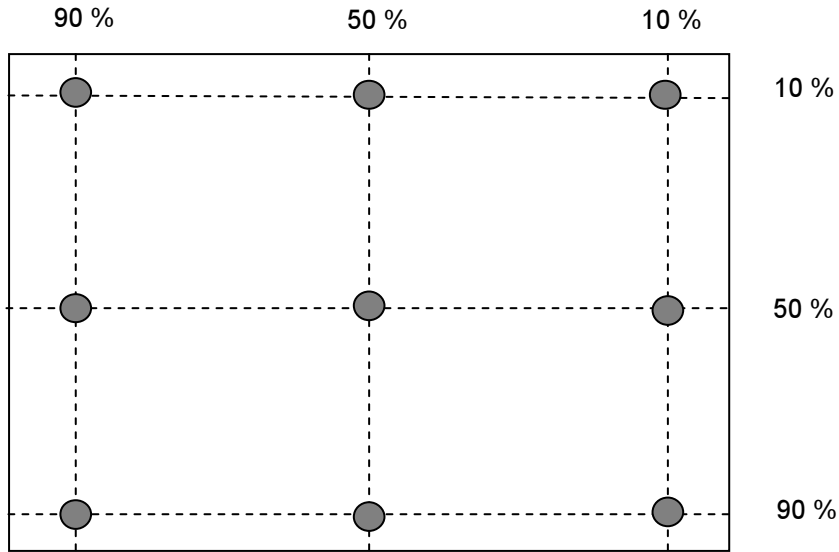

Note 3: The luminance uniformity of 9 points is defined by dividing the minimum luminance values by the maximum test point luminance

$$\delta_{w9} = \frac{\text{Minimum Brightness of nine points}}{\text{Maximum Brightness of nine points}}$$

Note 4 : Definition of contrast ratio (CR):

$$\text{Contrast ratio (CR)} = \frac{\text{Brightness on the "White" state}}{\text{Brightness on the "Black" state}}$$

Note 5 : Definition of cross talk (CT)

$$CT = | YB - YA | / YA \times 100 (\%)$$

Where

YA = Luminance of measured location without gray level 0 pattern (cd/m2)

YB = Luminance of measured location with gray level 0 pattern (cd/m2)

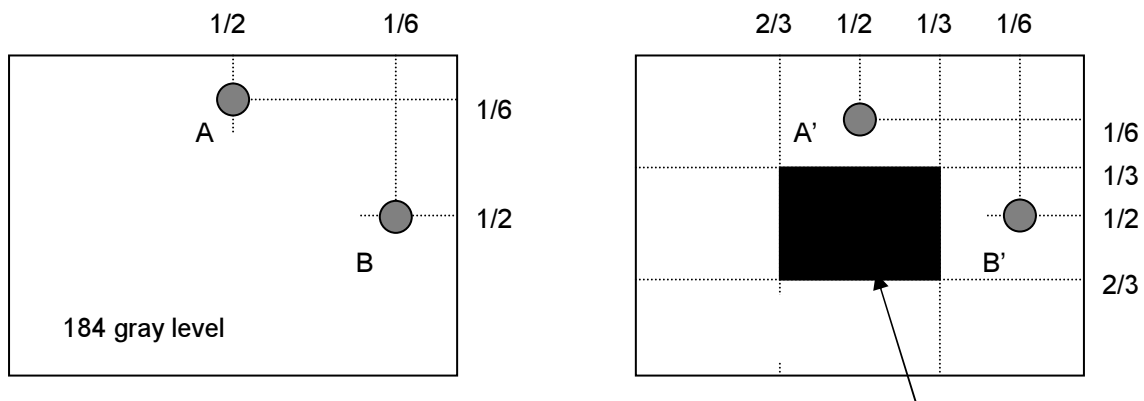

Note 6: Definition of response time:

The output signals of photo detector are measured when the input signals are changed from “White” to “Black” (falling time) and from “Black” to “White” (rising time), respectively. The response time interval is between 10% and 90% of amplitudes. Please refer to the figure as below.

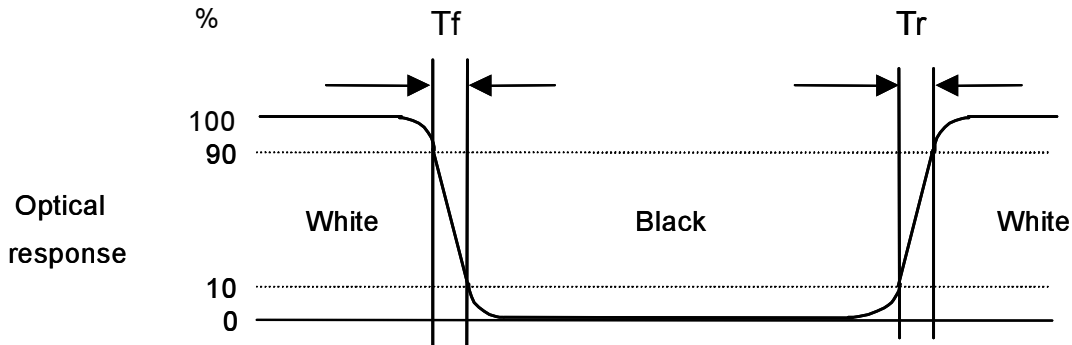

Note 7: Definition of viewing angle

Viewing angle is the measurement of contrast ratio ≥ 10 , at the screen center, over a 180° horizontal and 180° vertical range (off-normal viewing angles). The 180° viewing angle range is broken down as below: 90° (θ) horizontal left and right, and 90° (ϕ) vertical high (up) and low (down). The measurement direction is typically perpendicular to the display surface with the screen rotated to its center to develop the desired measurement viewing angle.

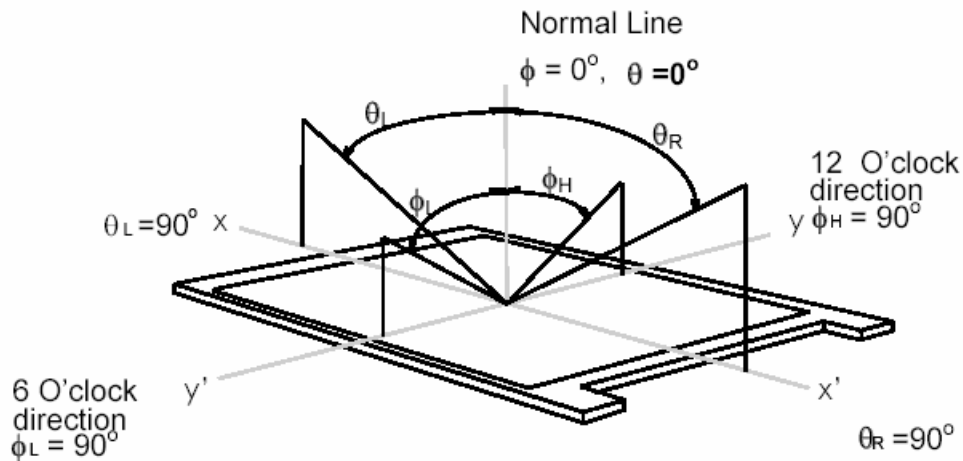

Note 8: Note 8: Definition of Gamma Value

Generally, Gamma Value is defined as the slope of a Gray Level – Luminance curve in log-log space, that is

$$\gamma = d \log(\text{Luminance}) / d \log(\text{Gray Level})$$

The Gamma Value defined in this spec is Linear Regression ($\gamma_1, \gamma_2, \gamma_3, \dots, \gamma_{16}$). γ_1 to γ_{16} are the section gamma of the following 17 sampling points, GL(0), GL(16), GL(32), GL(48), GL(64), GL(80), GL(96), GL(112), GL(128), GL(144), GL(160), GL(176), GL(192), GL(208), GL(224), GL(240) and GL(255), in 8 bits input.

3. Functional Block Diagram

The following diagram shows the functional block of the 15 inch color TFT/LCD module:

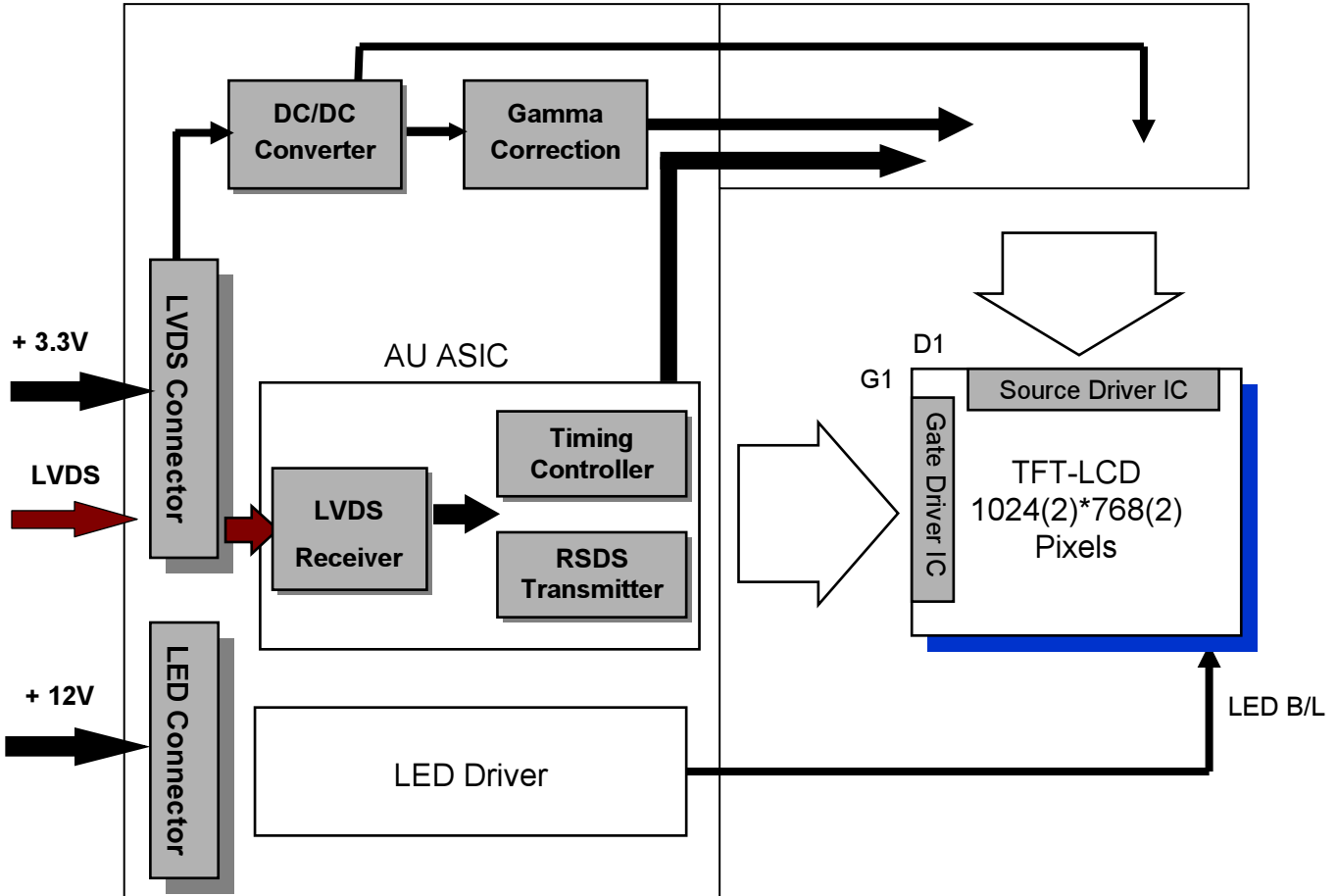

4. Absolute Maximum Ratings

4.1 Absolute Ratings of TFT LCD Module

Item	Symbol	Min	Max	Unit
Logic/LCD Drive Voltage	Vin	- 0.3	+3.6	[Volt]

4.2 Absolute Ratings of Environment

Item	Symbol	Min	Max	Unit
Operating Temperature	TOP	-30	+85	[°C]
Operation Humidity	HOP	8	90	[%RH]
Storage Temperature	TST	-30	+85	[°C]
Storage Humidity	HST	8	90	[%RH]

Note: Maximum Wet-Bulb should be 39 °C and no condensation.

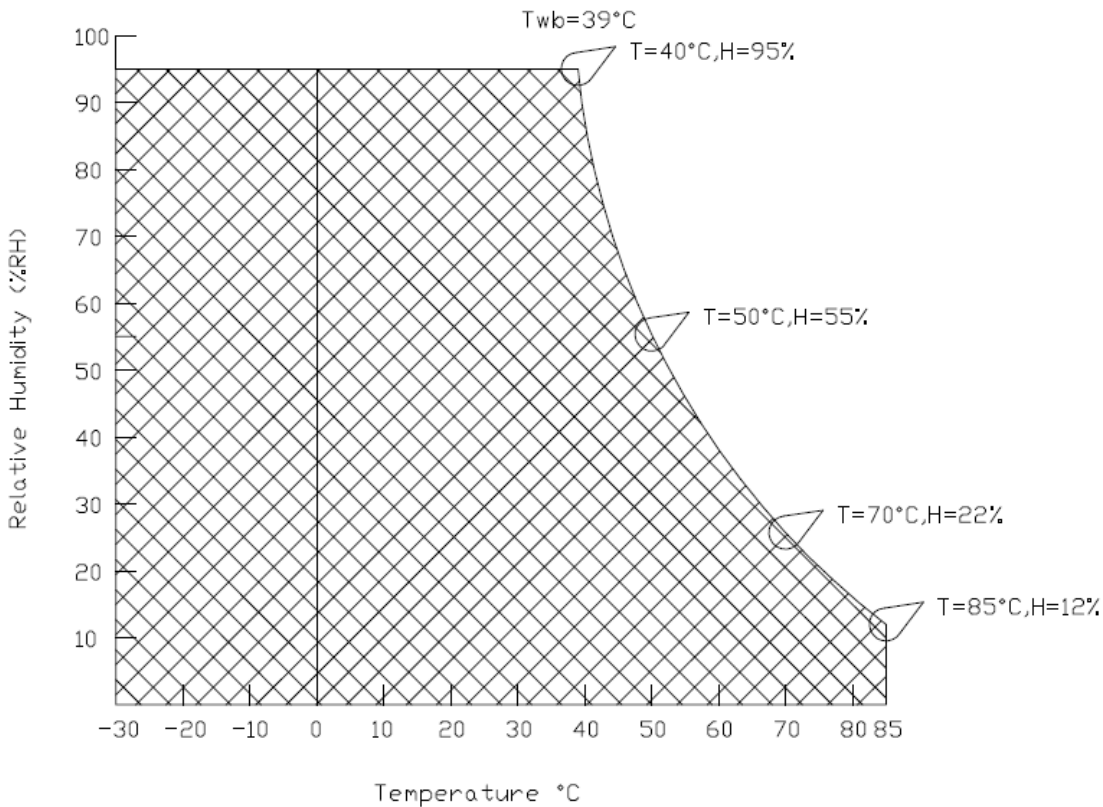

5. Electrical Characteristics

5.1 TFT LCD Module

5.1.1 Power Specification

Symbol	Parameter	Min	Typ	Max	Units	Remark
VDD	Logic/LCD Drive Voltage	3.0	3.3	3.6	[Volt]	±10%
IDD	VDD Current	-	700	840	[mA]	64 Gray Bar Pattern (VDD=3.3V, at 60Hz)
Irush	LCD Inrush Current	-	-	3	[A]	Note 1
PDD	VDD Power	-	2.31	2.77	[Watt]	64 Gray Bar Pattern (VDD=3.3V, at 60Hz)

Note 1: Measurement condition:

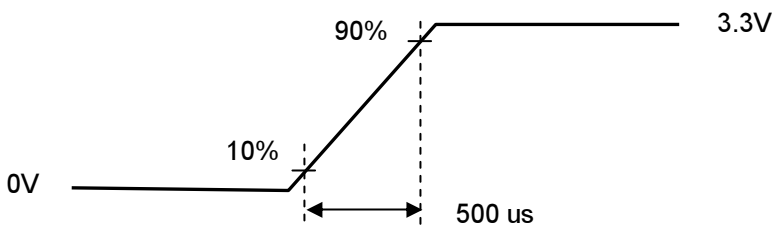
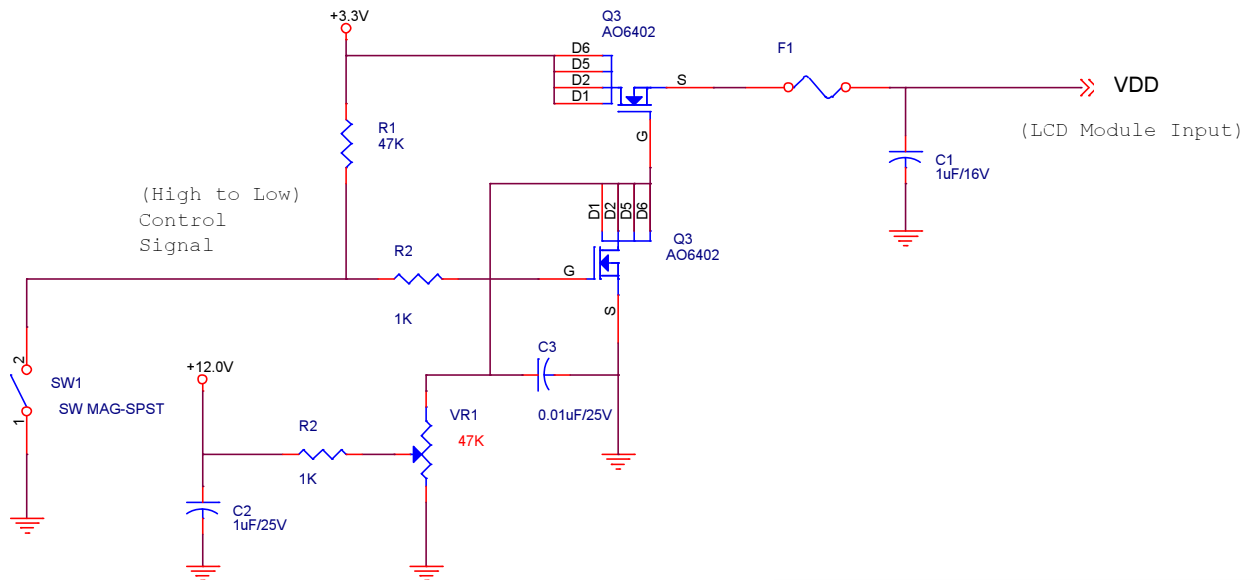

VDD rising time



64 Gray pattern

5.1.2 Signal Electrical Characteristics

Input signals shall be low or Hi-Z state when VDD is off.

Symbol	Item	Min.	Typ.	Max.	Unit	Remark
VTH	Differential Input High Threshold	-	-	100	[mV]	VCM=1.2V
VTL	Differential Input Low Threshold	100	-	-	[mV]	VCM=1.2V
VID	Input Differential Voltage	100	400	600	[mV]	
VICM	Differential Input Common Mode Voltage	1.15	1.2	1.45	[V]	VTH/VTL=±100mV

Note: LVDS Signal Waveform.

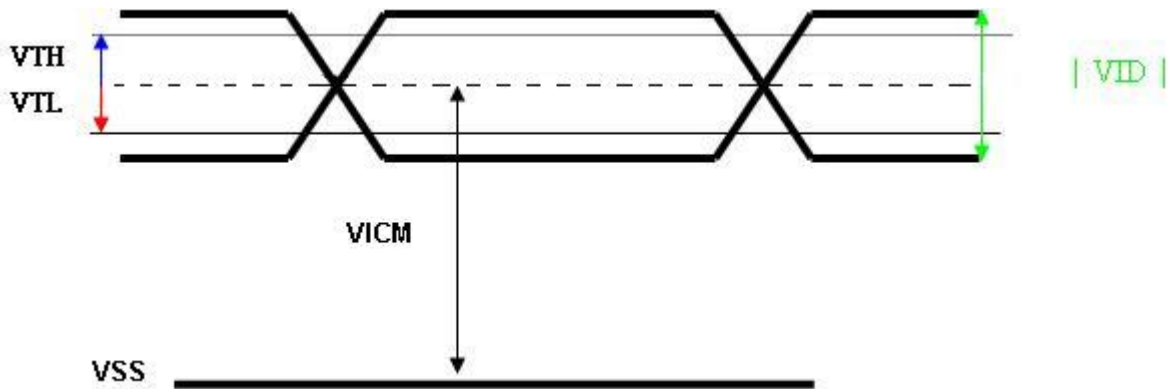

5.2 Backlight Unit

5.2.1 Parameter guideline for LED

Following characteristics are measured under stable condition using a LED driving board at 25 °C (Room Temperature).

Symbol	Parameter	Min	Typ	Max	Unit	Remark
Vcc	Input Voltage	10.8	12	12.6	Volt	
Ivcc	Input Current	-	0.61	-	A	100% Dimming
PLED	Power Consumption	-	7.32	10	Watt	100% Dimming
FPWM	PWM Dimming Frequency	200	-	20k	Hz	
	Swing Voltage	4.5	5	5.5		
	Dimming Duty Cycle	5	-	100	%	
Vanalog	Analog Dimming Voltage	2.0	5	5.5		5V, 100% Brightness
I _F	LED Forward Current	-	80	84	mA	Ta = 25°C
Operating Life		50000	-	-	Hrs	Ta = 25°C

Note 1: Ta means ambient temperature of TFT-LCD module.

Note 2: If G150XG01 V4 module is driven at high ambient temperature & humidity condition. The operating life will be reduced.

Note 3: Operating life means brightness goes down to 50% initial brightness. Min. operating life time is estimated data.

5.3 Touch Unit

5.3.1 Touch Electrical Specification

Symbol	Parameter	Min	Typ	Max	Units	Remark
VDD	Touch/ Logic Drive Voltage	4.75	5	5.25	[Volt]	±5%
VID	Input Differential Voltage		400		[mV]	Full-Speed mode; USB 2.0

6. Signal Characteristic

6.1 Pixel Format Image

Following figure shows the relationship between input signal and LCD pixel format.

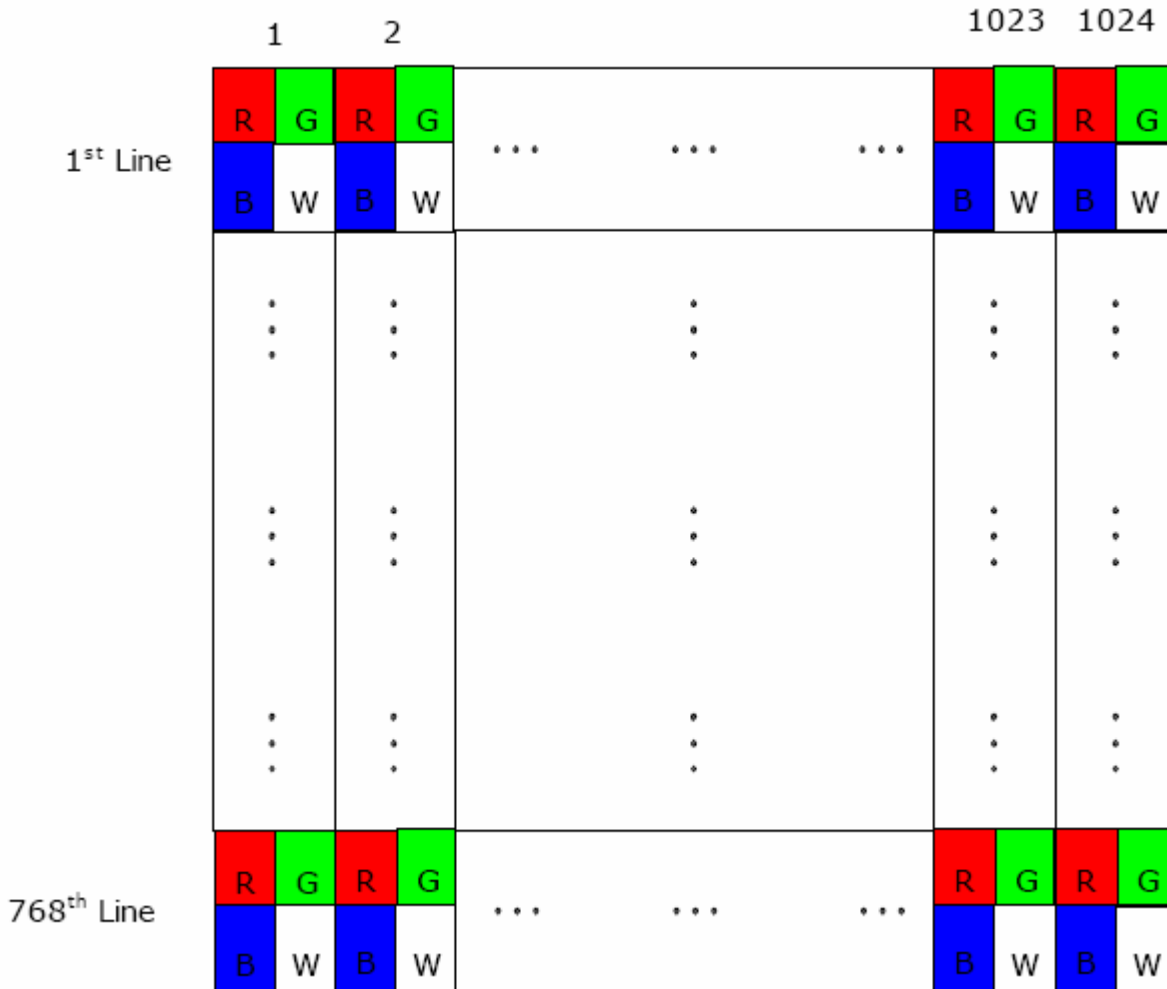

6.2 Scanning Direction

The following figures show the image seen from the front view. The arrow indicates the direction of scan.

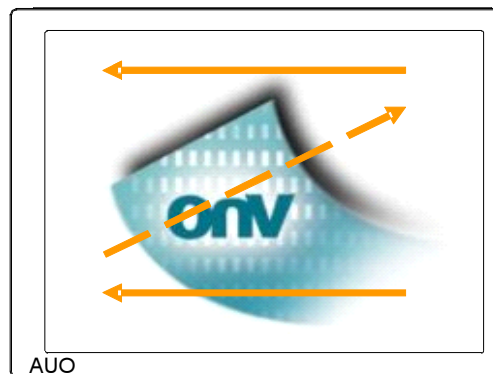
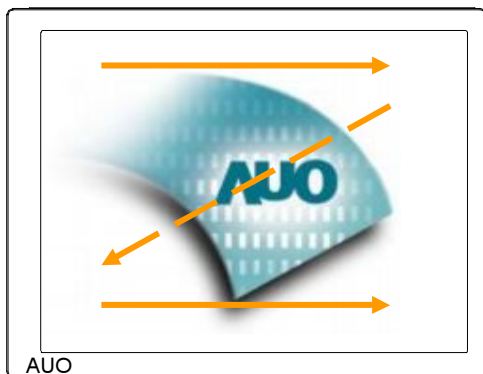

Fig. 1 Normal scan (Pin4, REV = Low or NC)

Fig. 2 Reverse scan (Pin4, REV = High)

6.3 Signal Description

The module using a pair of LVDS receiver SN75LVDS82(Texas Instruments) or compatible. LVDS is a differential signal technology for LCD interface and high speed data transfer device. Transmitter shall be SN75LVDS83(negative edge sampling) or compatible. The first LVDS port(RxOxxx) transmits odd pixels while the second LVDS port(RxExxx) transmits even pixels.

Input Signal Interface		
Pin No.	Symbol	Description
1	VDD	Power Supply, 3.3V (typical)
2	VDD	Power Supply, 3.3V (typical)
3	GND	Ground
4	REV	Reverse Scan [H: Enable; L/NC: Disable]*Note1,3
5	Rin0-	- LVDS differential data input
6	Rin0+	+ LVDS differential data input
7	GND	Ground
8	Rin1-	- LVDS differential data input
9	Rin1+	+ LVDS differential data input
10	GND	Ground
11	Rin2-	- LVDS differential data input
12	Rin2+	+ LVDS differential data input
13	GND	Ground
14	ClkIN-	- LVDS differential clock input
15	ClkIN+	+ LVDS differential clock input
16	GND	Ground
17	Rin3-	- LVDS differential data input *Note2
18	Rin3+	+ LVDS differential data input *Note2
19	NC/GND	Reserved for AUO internal test. Please set it as NC or Ground.
20	SEL68	Selection for 6 bits/8bits LVDS data input[H/NC: 6bits, L: 8bits]*Note1,3

Note 1: Input signals shall be in low status when VDD is off.

Note 2: For 6 bits input mode, pin 17 and pin 18 must be floated.

Note 3: High stands for “3.3V”, Low stands for “0V”, NC stands for “No Connection”.

6.4 The Input Data Format

6.4.1 SEL68

SEL68 = "High" or "NC" for 6 bits LVDS Input

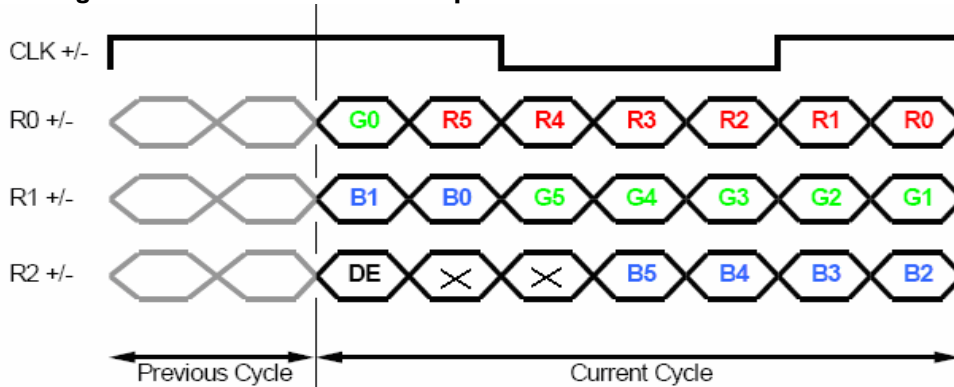

SEL68 = "Low" for 8 bits LVDS Input

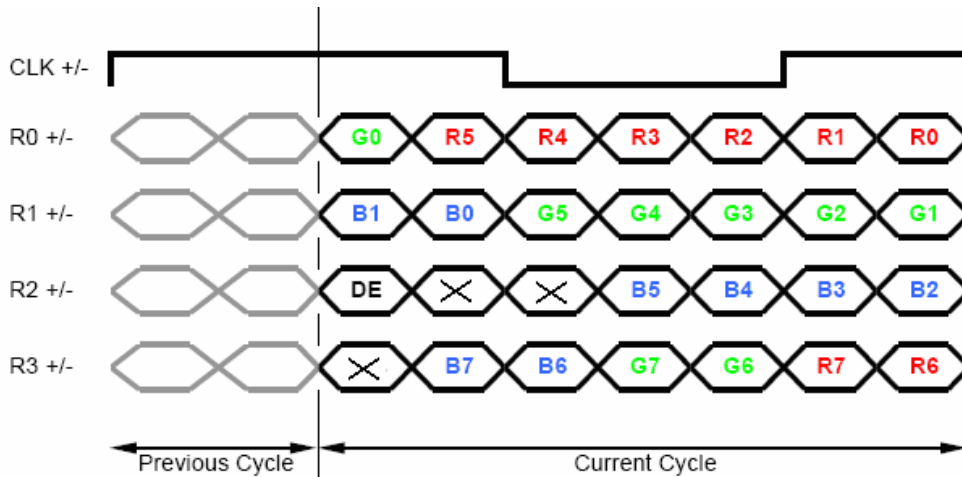

Signal Name	Description	Remark
R7	Red Data 7	Red-pixel Data For 6Bits LVDS input MSB: R5 ; LSB: R0 For 8Bits LVDS input MSB: R7 ; LSB: R0
R6	Red Data 6	
R5	Red Data 5	
R4	Red Data 4	
R3	Red Data 3	
R2	Red Data 2	
R1	Red Data 1	
R0	Red Data 0	
G7	Green Data 7	Green-pixel Data For 6Bits LVDS input MSB: G5 ; LSB: G0 For 8Bits LVDS input MSB: G7 ; LSB: G0
G6	Green Data 6	
G5	Green Data 5	
G4	Green Data 4	
G3	Green Data 3	
G2	Green Data 2	
G1	Green Data 1	
G0	Green Data 0	

B7 B6 B5 B4 B3 B2 B1 B0	Blue Data 7 Blue Data 6 Blue Data 5 Blue Data 4 Blue Data 3 Blue Data 2 Blue Data 1 Blue Data 0	Blue-pixel Data For 6Bits LVDS input MSB: B5 ; LSB: B0 For 8Bits LVDS input MSB: B7 ; LSB: B0
RxCLKIN	LVDS Data Clock	The typical frequency is 65MHz. The signal is used to strobe the pixel data and DE signals. All pixel data shall be valid at the falling edge when the DE signal is high.
DE	Data Enable Signal	When the signal is high, the pixel data shall be valid to be displayed.

Note: Output signals from any system shall be low or Hi-Z state when VDD is off.

6.5 Interface Timing

6.5.1 Timing Characteristics

Signal	Parameter	Symbol	Min.	Typ.	Max.	Unit	
Clock Timing	Clock frequency	$1/T_{Clock}$	50	65	80	MHz	
Vsync Timing	Vertical Section	Period	T_V	776	806	1023	T_{Line}
		Active	T_{VD}	-	768	-	
		Blanking	T_{VB}	8	38	255	
Hsync Timing	Horizontal Section	Period	T_H	1074	1344	2047	T_{Clock}
		Active	T_{HD}	-	1024	-	
		Blanking	T_{HB}	50	320	1023	
Frame Rate		F	50	60	75	Hz	

Note: DE mode only.

Note : Typical value refer to VESA STANDARD

6.5.2 Input Timing Diagram

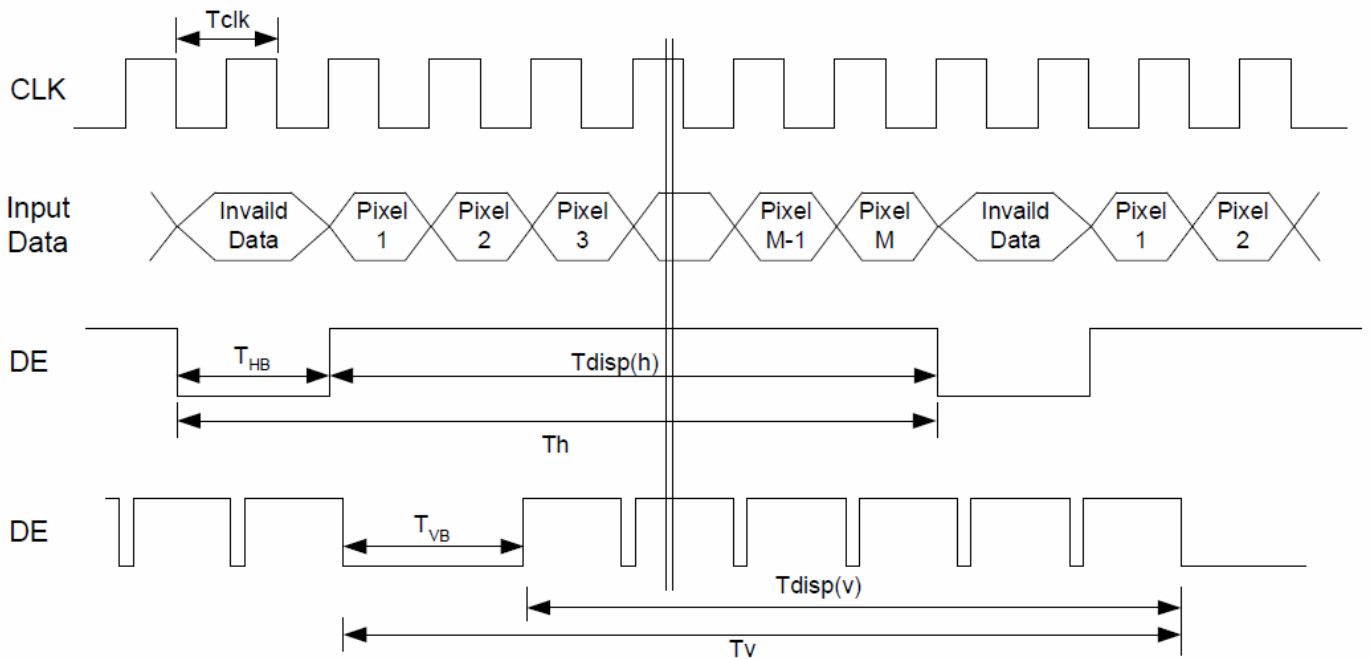

6.6 Power ON/OFF Sequence

VDD power and LED on/off sequence is as below. Interface signals are also shown in the chart. Signals from any system shall be Hi-Z state or low level when VDD is off.

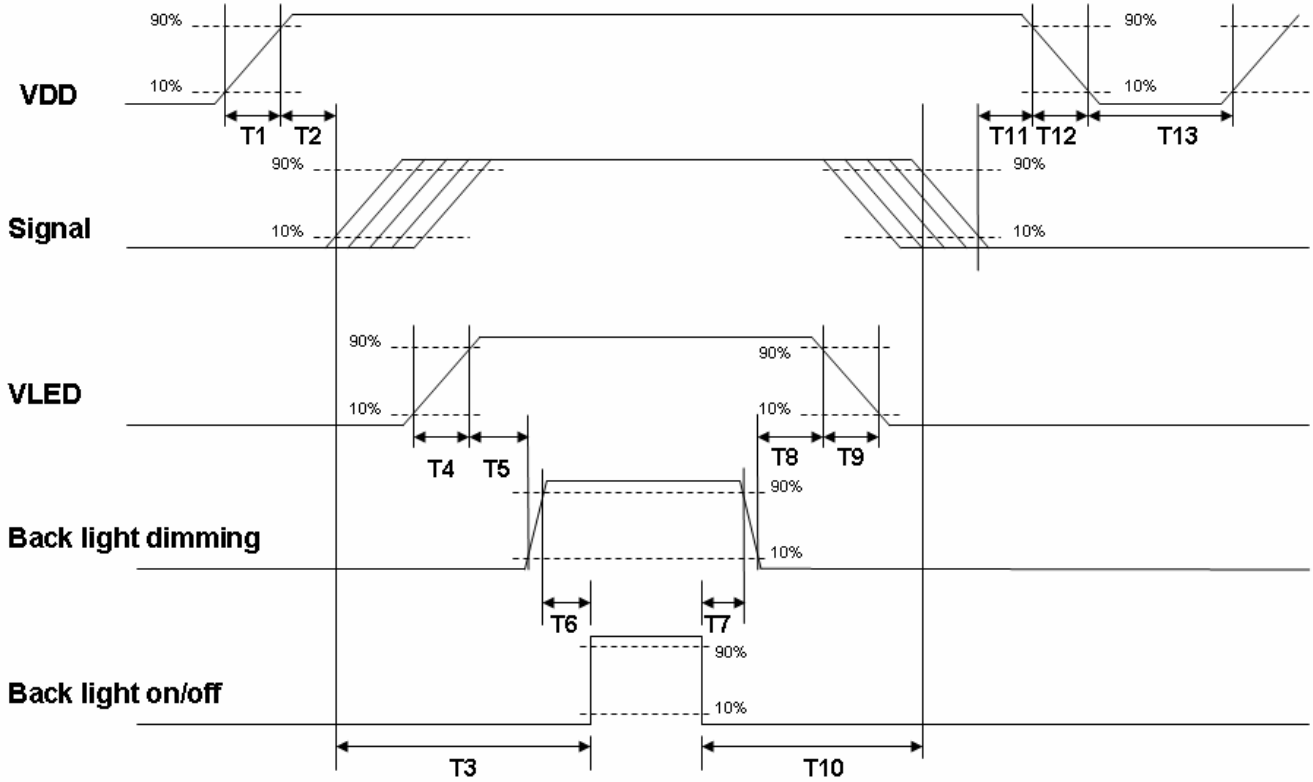

Power ON/OFF sequence timing

Parameter	Value			Units
	Min.	Typ.	Max.	
T1	0.5	-	10	[ms]
T2	30	40	50	[ms]
T3	200	-	-	[ms]
T4	0.5	-	10	[ms]
T5	10	-	-	[ms]
T6	10	-	-	[ms]
T7	0	-	-	[ms]
T8	10	-	-	[ms]
T9	-	-	10	[ms]
T10	110	-	-	[ms]
T11	0	16	50	[ms]
T12	-	-	10	[ms]
T13	1000	-	-	[ms]



the power when you plug the cable into the input connector or pull the cable out of the connector.

7. Connector & Pin Assignment

Physical interface is described as for the connector on module. These connectors are capable of accommodating the following signals and will be following components.

7.1 TFT-LCD Signal: LVDS Interface Connector

Connector Name / Designation	Signal Connector
Manufacturer	STM or compatible
Connector Model Number	MSB240420-E
Mating Housing Part Number	P240420 or compatible

Pin#	Signal Name	Pin#	Signal Name
1	VDD	2	VDD
3	GND	4	REV
5	Rin0-	6	Rin0+
7	GND	8	Rin1-
9	Rin1+	10	GND
11	Rin2-	12	Rin2+
13	GND	14	ClkIN-
15	ClkIN+	16	GND
17	Rin3-	18	Rin3+
19	NC/GND		

7.1.1 Connector Illustration

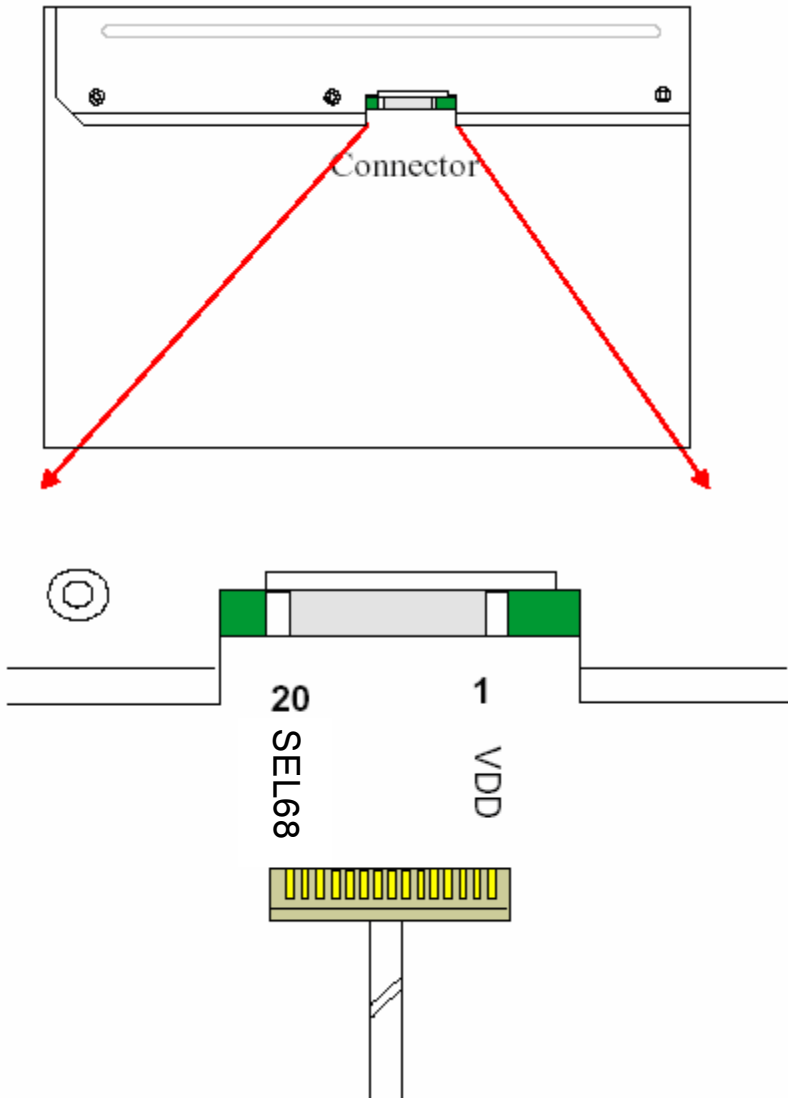

7.2 LED Backlight Unit:

LED Driver Connector

Connector Name / Designation	LED Connector
Manufacturer	E&T or compatible
Connector Model Number	3808K-F05N-02R or compatible
Mating Connector Model Number	H208K-P05N-02B or compatible

LED Driver Connector Pin Assignment

Pin#	Symbol	Signal Name
1	Vcc	12V
2	GND	GND
3	Enable	5V-On / 0V-Off
4	Dimming	PWM Dimming or Analog Dimming
5	NC	NC

7.3 Touch Unit:

Touch Driver Connector

Connector Name / Designation	For TP Connector
Manufacturer	Hirose
Type / Part Number	DF13A-4P-1.25H
Mating Connector / Part Number	DF13-4S-1.25C

Touch Driver Connector Pin Assignment

Pin#	Symbol	Signal Name
1	GND	GND
2	+Data	D-USB Full Speed Positive Data Upstream Port / CLOCK
3	-Data	D-USB Full Speed Negative Data Upstream Port / DATA

8. Reliability Test Criteria

Items	Required Condition	Note
Temperature Humidity Bias	50°C/80%,300 hours	
High Temperature Operation	85°C,300 hours	
Low Temperature Operation	-30 °C,300 hours	
Hot Storage	85°C, 300 hours	
Cold Storage	-30 °C,300 hours	
Thermal Shock Test	-10 °C/30 min ,60 °C /30 min ,100cycles	
Shock Test (Non-Operating)	50G,20ms,Half-sine wave,(±X, ±Y, ±Z)	
Vibration Test (Non-Operating)	1.5G, (10~200Hz, P-P) 30 mins/axis (X, Y, Z)	
On/off test	On/10 sec, Off/10 sec, 30,000 cycles	
ESD	Contact Discharge: ± 8KV, 150pF(330Ω) 1sec, 8 points, 25 times/ point Air Discharge: ± 15KV, 150pF(330Ω) 1sec, 8 points, 25 times/ point	Note 1

Note1: According to EN61000-4-2, ESD class B: Some performance degradation allowed. No data lost
 . Self-recoverable. No hardware failures.

Note 2:

- Water condensation is not allowed for each test items.
- Each test is done by new TFT-LCD module. Don't use the same TFT-LCD module repeatedly for reliability test.
- The reliability test is performed only to examine the TFT-LCD module capability.
- To inspect TFT-LCD module after reliability test, please store it at room temperature and room humidity for 24 hours at least in advance.
- No function failure occurs.

9. Mechanical Characteristics

9.1 LCM Outline Dimension (Front View)

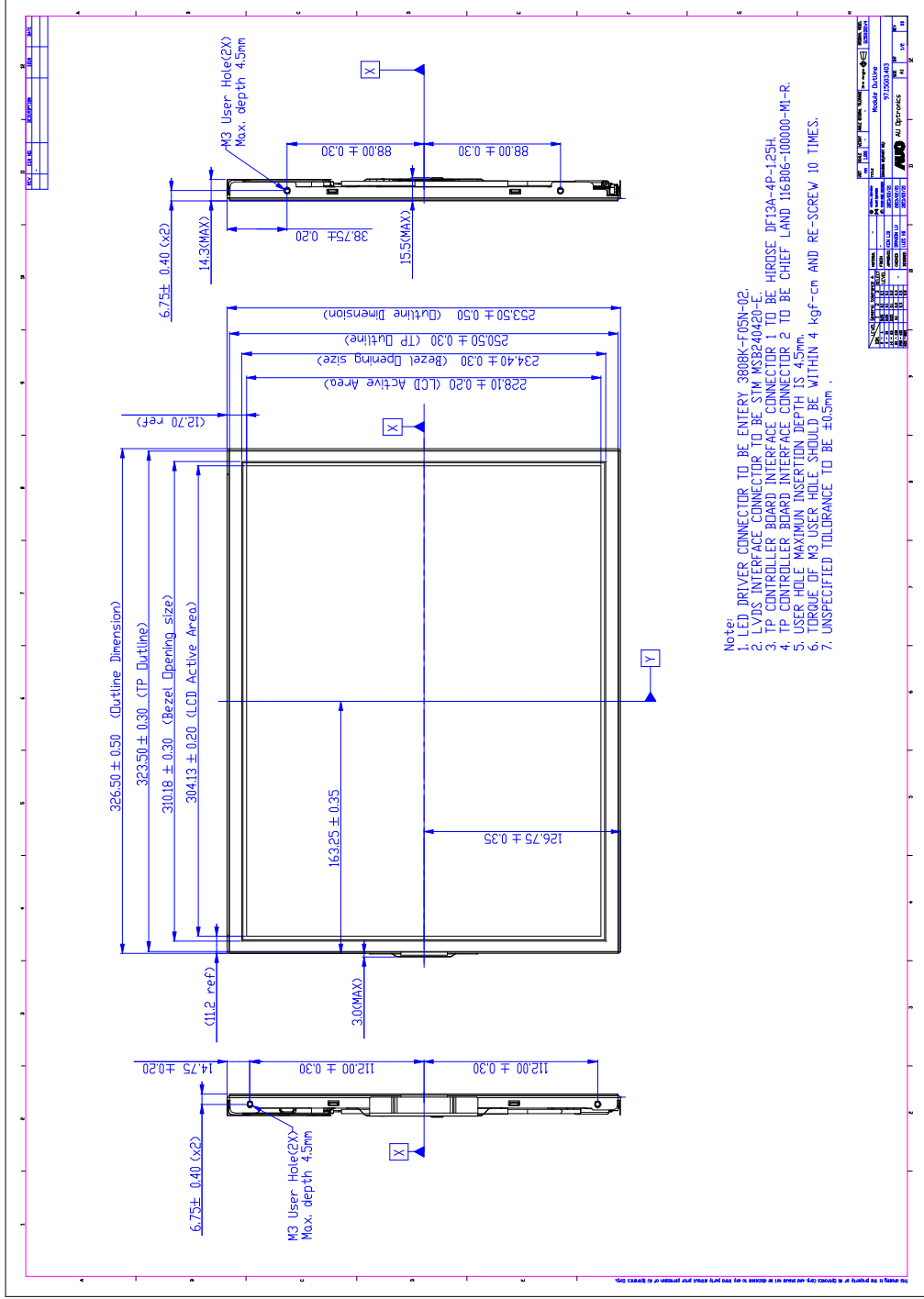

9.2 LCM Outline Dimension (Rear View)

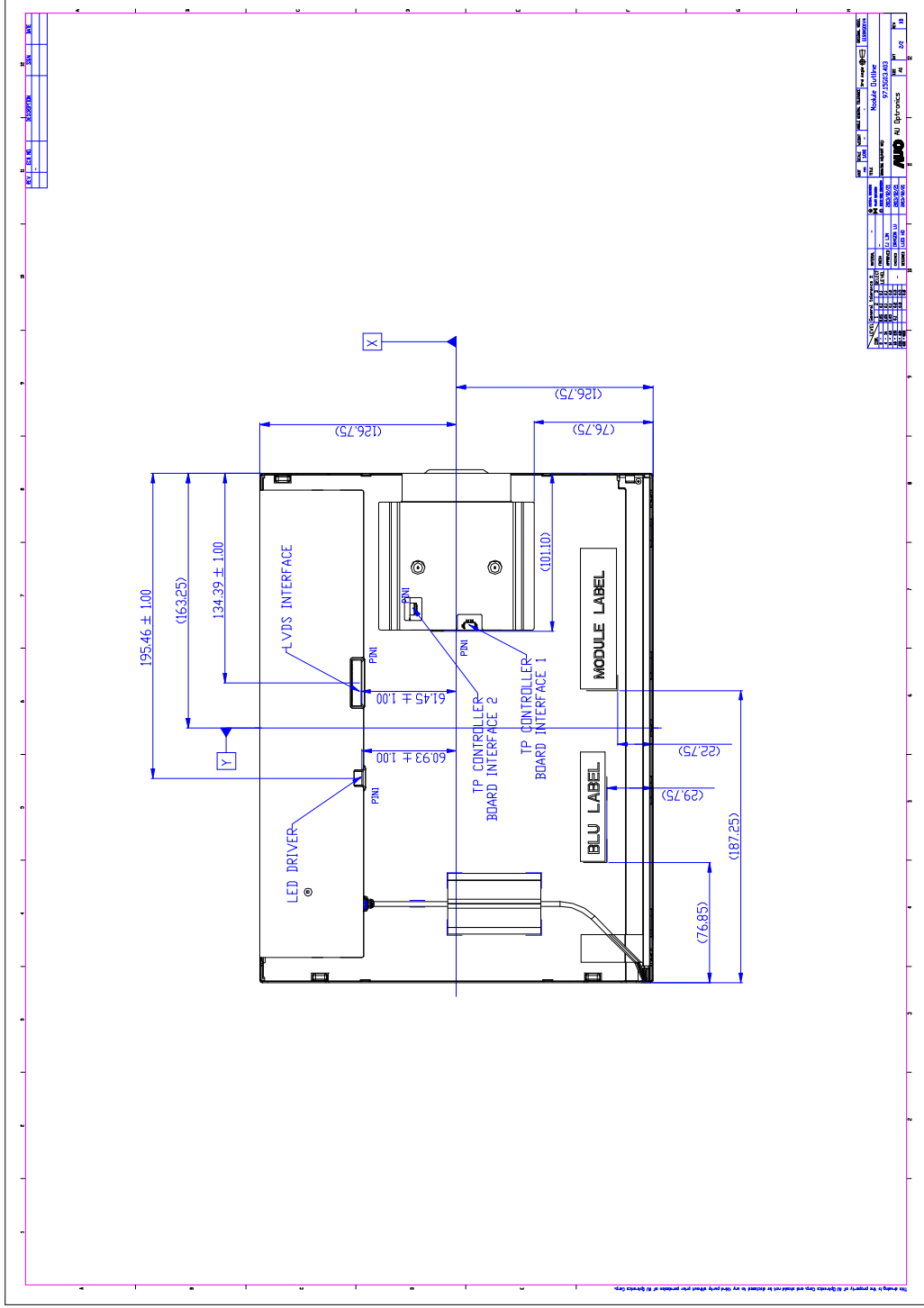

10. Label and Packaging

10.1 Shipping Label (on the rear side of TFT-LCD display)

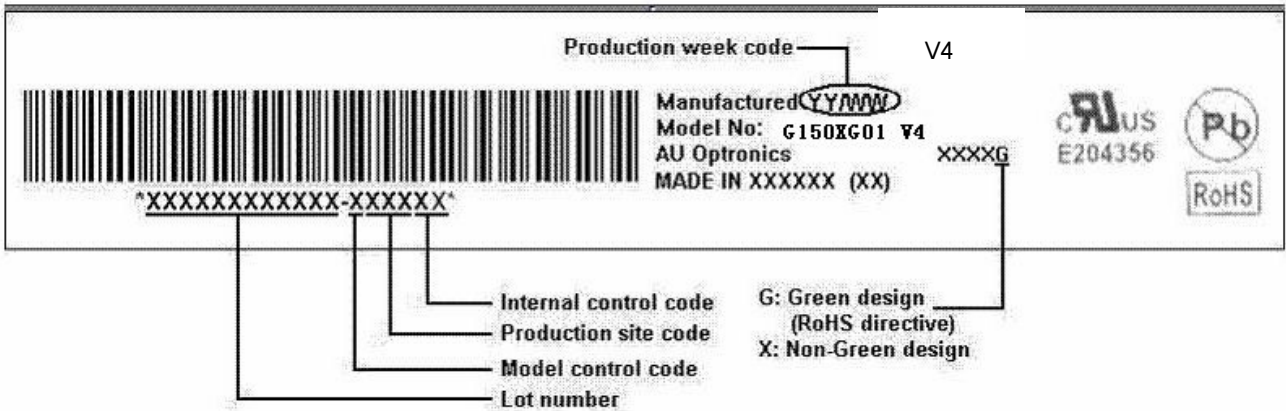

10.2 Carton Package

Max capacity : 10 TFT-LCD module per carton

Max weight: 13.0 kg per carton

Outside dimension of carton: 428mm(L)*374mm(W)*351mm(H)

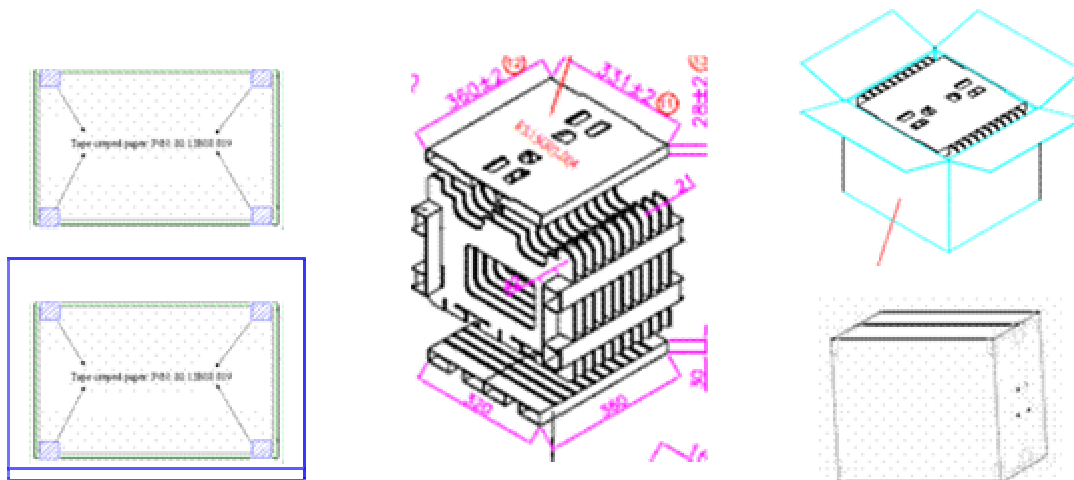

11 Safety

11.1 Sharp Edge Requirements

There will be no sharp edges or comers on the display assembly that could cause injury.

11.2 Materials

11.2.1 Toxicity

There will be no carcinogenic materials used anywhere in the display module. If toxic materials are used, they will be reviewed and approved by the responsible AUO toxicologist.

11.2.2 Flammability

All components including electrical components that do not meet the flammability grade UL94-V1 in the module will complete the flammability rating exception approval process.

The printed circuit board will be made from material rated 94-V1 or better. The actual UL flammability rating will be printed on the printed circuit board.

11.3 Capacitors

If any polarized capacitors are used in the display assembly, provisions will be made to keep them from being inserted backwards.

11.4 National Test Lab Requirement

The display module will satisfy all requirements for compliance to:

UL 1950, First Edition

U.S.A. Information Technology Equipment

Our company network supports you worldwide with offices in Germany, Great Britain, Italy, Turkey and the USA. For more information please contact:



DATA DISPLAY GROUP

Distec GmbH

Augsburger Str. 2b
82110 Germering
Germany

Phone: +49 (0)89 / 89 43 63-0
Fax: +49 (0)89 / 89 43 63-131
E-Mail: info@datadisplay-group.de
Internet: www.datadisplay-group.de

Display Technology Ltd.

5 The Oaks Business Village
Revenge Road, Lordswood
Chatham, Kent, ME5 8LF
United Kingdom

Phone: +44 (0)1634 / 67 27 55
Fax: +44 (0)1634 / 67 27 54
E-Mail: info@datadisplay-group.co.uk
Internet: www.datadisplay-group.co.uk

Apollo Display Technologies, Corp.

87 Raynor Avenue, Unit 1 Ronkonkoma, NY
11779

United States of America

Phone: +1 631 / 580-43 60
Fax: +1 631 / 580-43 70
E-Mail: info@datadisplay-group.com
Internet: www.datadisplay-group.com

Sales Partner:**REM Italy s.a.s.**

di Michieletto Flavio & C.
Via Obbia Bassa, 10
I-35010 Trebaseleghe (PD)
Italy
Phone: +39 335 521 37 89
E-Mail: info@remitaly.com
Internet: www.remitaly.com

Sales Partner:**DATA DISPLAY BİLİŞİM TEKNOLOJİLERİ
İÇ VE DIŞ TİCARET LİMİTED ŞİRKETİ**

Barbaros Mh Ak Zamabak Sk A Blok
D:143 Ataşehir/İstanbul
Turkey
Phone: +90 (0)216 / 688 04 68
Fax: +90 (0)216 / 688 04 69
E-Mail: info@data-display.com.tr
Internet: www.data-display.com.tr